

**Hot Swap™ Controller**
**FEATURES**

- **Full Voltage Control for Hot Swap Applications**  
*CompactPCI High Availability Compatible*
  - **On-board 15V High Side Driver Generation**  
 Allows use of Low On-resistance N-Channel FETS
  - **Undervoltage Lockout**
  - **Electronic Circuit Breakers**
  - **Card Insertion Detection**
  - **Host VCC Detection**
  - **Card Voltage Sequencing**
- **Flexible Reset Control**
  - **Low Voltage Resets**
  - **Host Reset Filtering**
  - **Soft Reset**
- **Adjustable Power-on Slew Rate**
- **Supports Mixed Voltage Cards**
- **Integrated 4K Bit 2-Wire E<sup>2</sup>PROM Memory**
  - **Data Download™ Mode [Simplifies Downloading of Configuration Memory into Interface ASIC or MCU]**

**DESCRIPTION**

The SMH4042 is a fully integrated hot swap controller that provides complete power control for add-in cards ranging in use for basic hot swap systems to high availability systems. It detects proper insertion of the card and senses valid supply voltage levels at the backplane. Utilizing external low on-resistance N-channel MOSFETs, card power is ramped by two high-side driver outputs that are slew-rate limited at 250V/s.

The SMH4042 continuously monitors the host supplies, the add-in card supplies and the add-in card current. If the SMH4042 detects the current is higher than the programmed value it will shut down the MOSFETs and issue a fault status back to the host.

The on board E<sup>2</sup>PROM can be used as configuration memory for the individual card or as general purpose memory. The proprietary DataDownload mode provides a more direct interface to the E<sup>2</sup>PROM, simplifying access by the add-in card's controller or ASIC.

**APPLICATIONS**

- **CompactPCI Hot Swap Control**
- **VME Live Insertion Control**

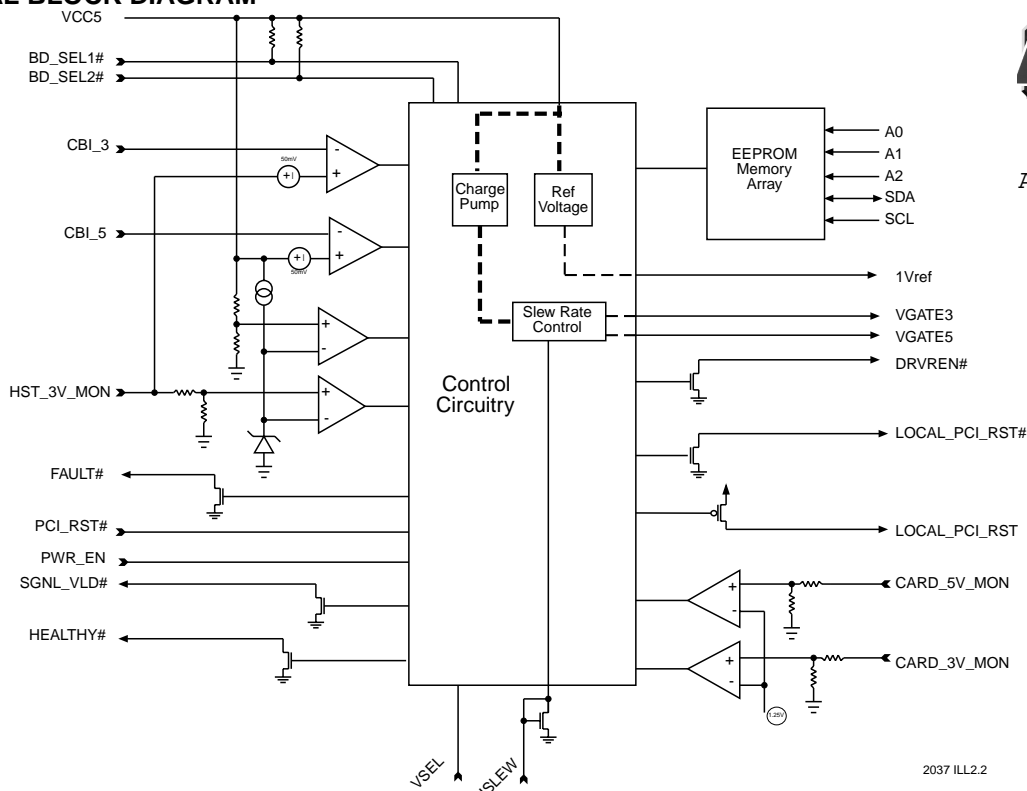
**FUNCTIONAL BLOCK DIAGRAM**

 ASSOCIATE  
 MEMBER

2037 ILL2.2



## PIN CONFIGURATIONS SOIC and SSOP

Symbol	Pin	Description
CBI_5	1	Circuit Breaker Input (5V)
DRVREN#	2	High Side Driver Enable
ISLEW	3	Slew Rate Control
FAULT#	4	Fault Output Active Low
1Vref	5	1Volt Reference Output
VSEL	6	Voltage Select Input
PWR_EN	7	Power On Enable Input
A0	8	Memory Address 0 <b>(NC or Gnd)</b>
LOCAL_PCI_RST#	9	Back End Reset Output <b>(Active Low)</b>
A1	10	Memory Address 1
A2	11	Memory Address 2
BD_SEL2#	12	Board Select 2
BD_SEL1#	13	Board Select 1
GND	14	Ground
HEALTHY#	15	Backend Power On
SGNL_VLD#	16	Signals Valid Output
PCI_RST#	17	Host reset input
SDA	18	Serial Data I/O
SCL	19	Serial Clock Input
LOCAL_PCI_RST	20	Back End Reset Output <b>(Active High)</b>
CARD_3V_MON	21	Card-side 3 Volt Monitor Input
VGATE3	22	High Side Drive Output
HST_3V_MON	23	Host 3V Monitor Input
CBI_3	24	Circuit Breaker Input (3V)
CARD_5V_MON	25	Card-side 5 Volt Monitor Input
NC	26	No Connect
VGATE5	27	High Side Drive Output
Vcc	28	Supply Voltage

2037 PGM T1.2

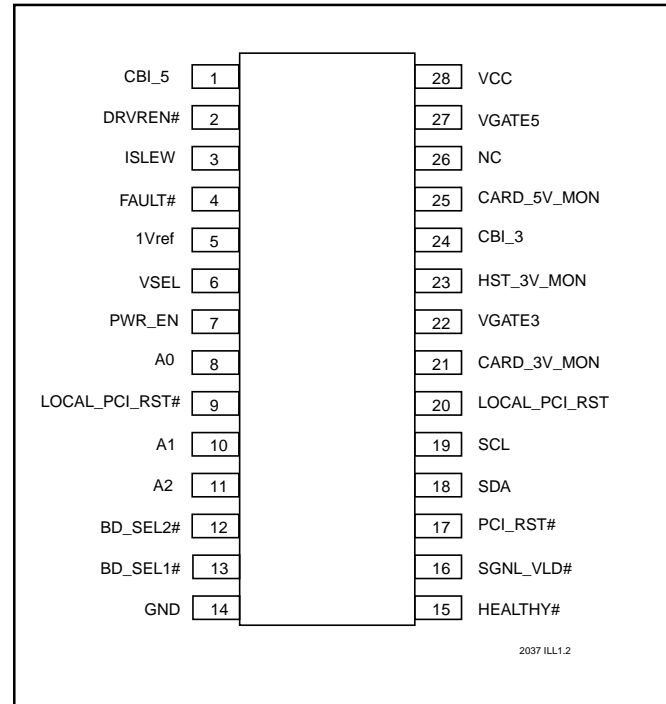

## RECOMMENDED OPERATING CONDITIONS

Condition	Min	Max
Temperature	-40°C	+85°C
Vcc	2.7V	5.5V

2037 PGM T2.0



## ABSOLUTE MAXIMUM RATINGS\*

Temperature Under Bias	-55°C to +125°C
Storage Temperature	-65°C to +150°C
Voltage on :	
HST_3V_MON, CARD_3V_MON V <sub>CC</sub> , CARD_5V_MON	7V
SGNL_VLD#, HEALTHY# & LOCAL_PCI_RESET#	7V
VGATE3, VGATE5, DRVREN#	16V
RESET	V <sub>CC</sub> +.7V
All Others	V <sub>CC</sub> +.7V
Output Short Circuit Current	100mA
Lead Solder Temperature (10 secs)	300°C

## \*COMMENT

Stresses listed under Absolute Maximum Ratings may cause permanent damage to the device. These are stress ratings only, and functional operation of the device at these or any other conditions outside those listed in the operational sections of this specification is not implied. Exposure to any absolute maximum rating for extended periods may affect device performance and reliability.

## DC ELECTRICAL CHARACTERISTICS T<sub>A</sub> = -40°C to +85°C

Symbol	Parameter	Part no. Suffix	Min.	Typ.	Max.	Units	
V <sub>CC</sub>	Operating Voltage See Note 1		1			V	
I <sub>CC1</sub>	Power Supply Current Operating				500	μA	
I <sub>CC2</sub>	Power Supply Current Writing				3	mA	
V <sub>TRIP</sub>	V <sub>TRIP</sub> Threshold Levels	V <sub>CC5</sub>	4.250	4.375	4.50	V	
		V <sub>CC5</sub>	4.50	4.625	4.75	V	
		HST_3V_MON	2.57	2.65	2.72	V	
		HST_3V_MON	2.72	2.8	2.87	V	
		HST_3V_MON	2.87	2.95	3.0	V	
		HST_3V_MON	3.0	3.1	3.17	V	
		CARD_5V_MON	M		V <sub>CC5</sub> V <sub>TRIP</sub> +50mV		V
		CARD_5V_MON	N		V <sub>CC5</sub> V <sub>TRIP</sub> -50mV		V
		CARD_3V_MON	M		HST_3V_MON +50mV		V
CARD_3V_MON	N		HST_3V_MON -50mV		V		
V <sub>TRHST</sub>	Trip Point Hysteresis			7		mV	
I <sub>LI</sub>	Input Leakage Current				2	μA	
I <sub>LO</sub>	Output Leakage Current				10	μA	
V <sub>IL</sub>	Input Low Voltage		-0.1		0.8	V	
V <sub>IH</sub>	Input High Voltage		2		V <sub>CC</sub> +1V	V	
V <sub>OL</sub>	Output Low Voltage, V <sub>CC</sub> = 5.0V, I <sub>OL</sub> = 2.1mA				0.4	V	
V <sub>OH</sub>	Output High Voltage, V <sub>CC</sub> = 5.0V, I <sub>OH</sub> = -400μA		2.4			V	
V <sub>OLRS</sub>	LOCAL_PCI_RESET# Output Low Voltage, I <sub>OL</sub> = 3.2mA				0.4	V	
V <sub>OHRS</sub>	RESET Output High, I <sub>OH</sub> = -800μA		V <sub>CC</sub> -75V			V	
V <sub>OHVG</sub>	VGATE3, VGATE5 Output Voltage, I <sub>OH</sub> = 20μA		13	14	15	V	
V <sub>REF</sub>	Reference Output Voltage, No Load		0.95	1	1.05	V	
V <sub>CB</sub>	Circuit Breaker Trip Voltage, V <sub>CB</sub> (V <sub>CC</sub> -CBI_5) or V <sub>CB</sub> =(HST_3V_MON-CBI_3)		40	50	60	mV	

2037 PGM T3.4

Notes: 1. The SMH4042 will drive the reset outputs and voltage control signals to valid levels throughout the operating range of 1V to 5.5V. The balance of the logic will not be guaranteed operational unless V<sub>CC</sub> is greater than 2.7V.

2. Refer to the ordering information table for all valid combinations of options.



## SEQUENCER AC OPERATING CHARACTERISTICS (Over Recommended Operating Conditions)

Symbol	Parameter	Notes	Min.	Typ.	Max.	Units
$t_{VTPD}$	$V_{TRIP}$ to Power Down Delay	Host Voltage Input		1	5	$\mu s$
$t_{VTR}$	$V_{TRIP}$ to RESET Output Delay	Card Voltage Input		1	5	$\mu s$
$t_{PRLPR}$	PCI_RST# to LOCAL_PCI_RST#			.1	1	$\mu s$
$V_{RVALID}$	RESET Output Valid		1			V
$T_{SLEW}$	Slew Rate				250	V/Sec
$T_{HSE}$	BD_SEL# to Power-on Delay	BD_SEL# Noise filter	100	150	200	ms
$t_{PURST}$	Reset Timeout		100	150	200	ms
$t_{GLTICH}$	Glitch Reject Pulse Width				40	ns
$t_{OCF}$	Over-current to FAULT#			1		$\mu s$
$t_{OCVG}$	Over-current to VGATE Off			1		$\mu s$
$t_{CBTC}$	Circuit Breaker Time Constant	Powering-on		4		$\mu s$
		Operating		16		$\mu s$

2037 PGM T4.1

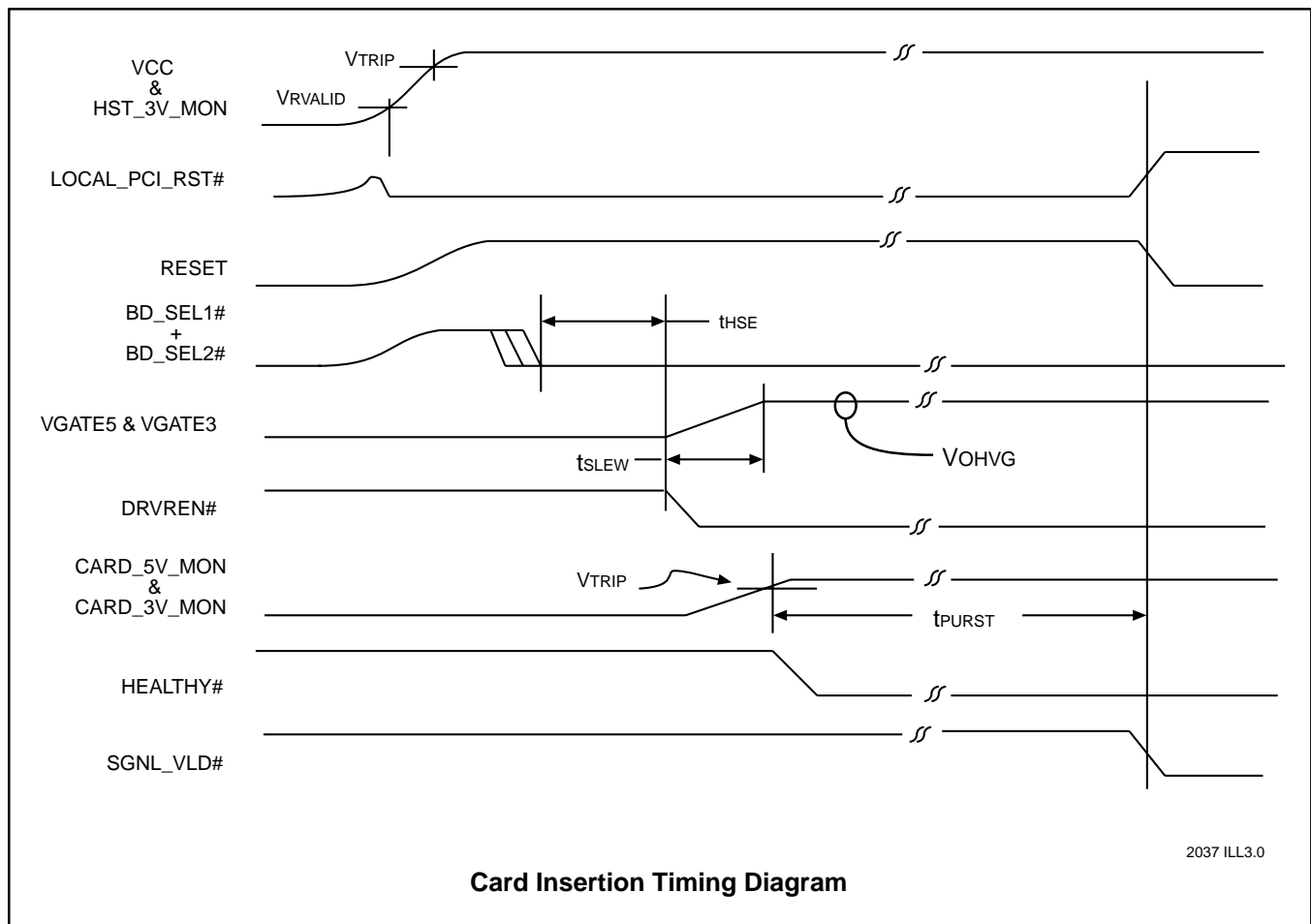

**Card Insertion Timing Diagram**

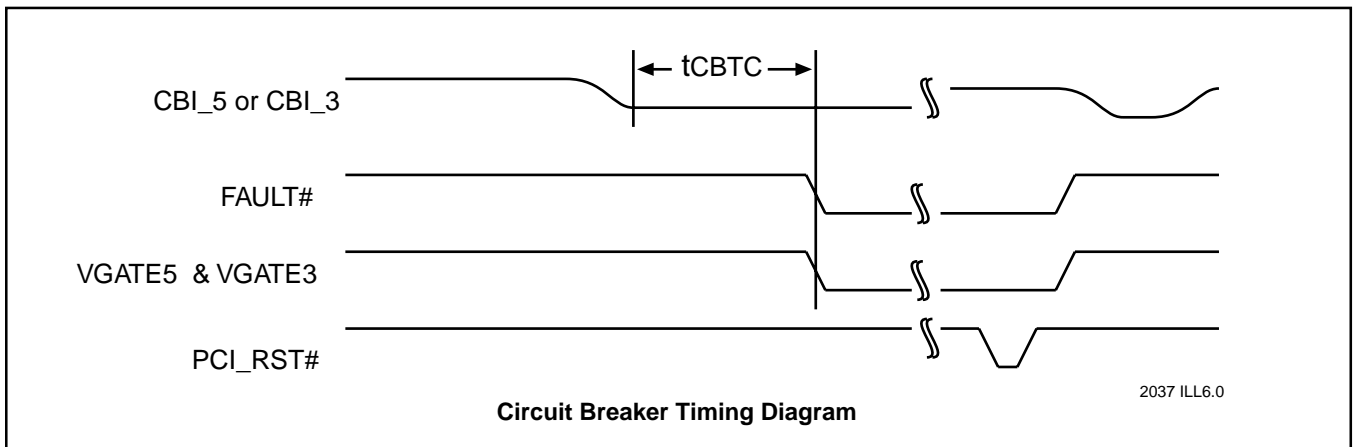
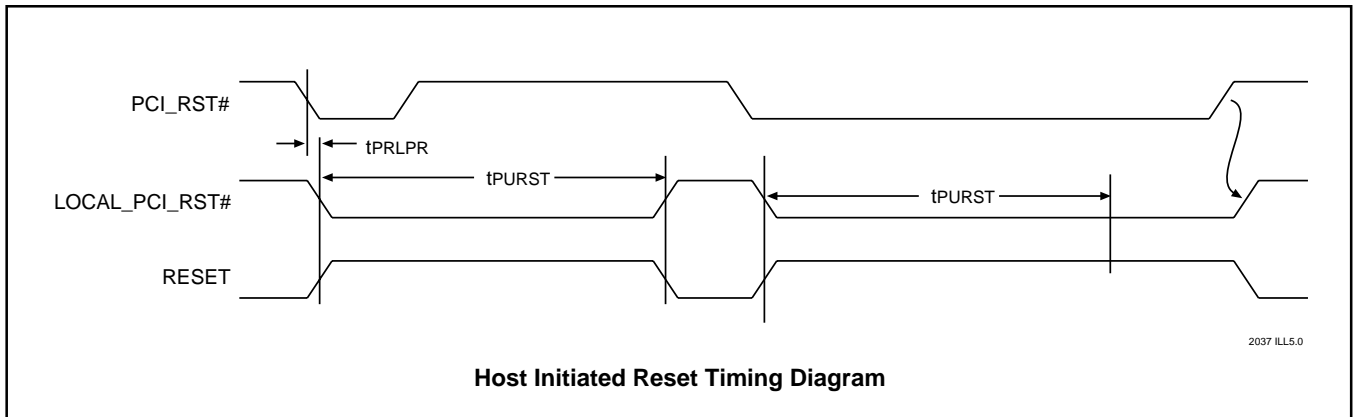
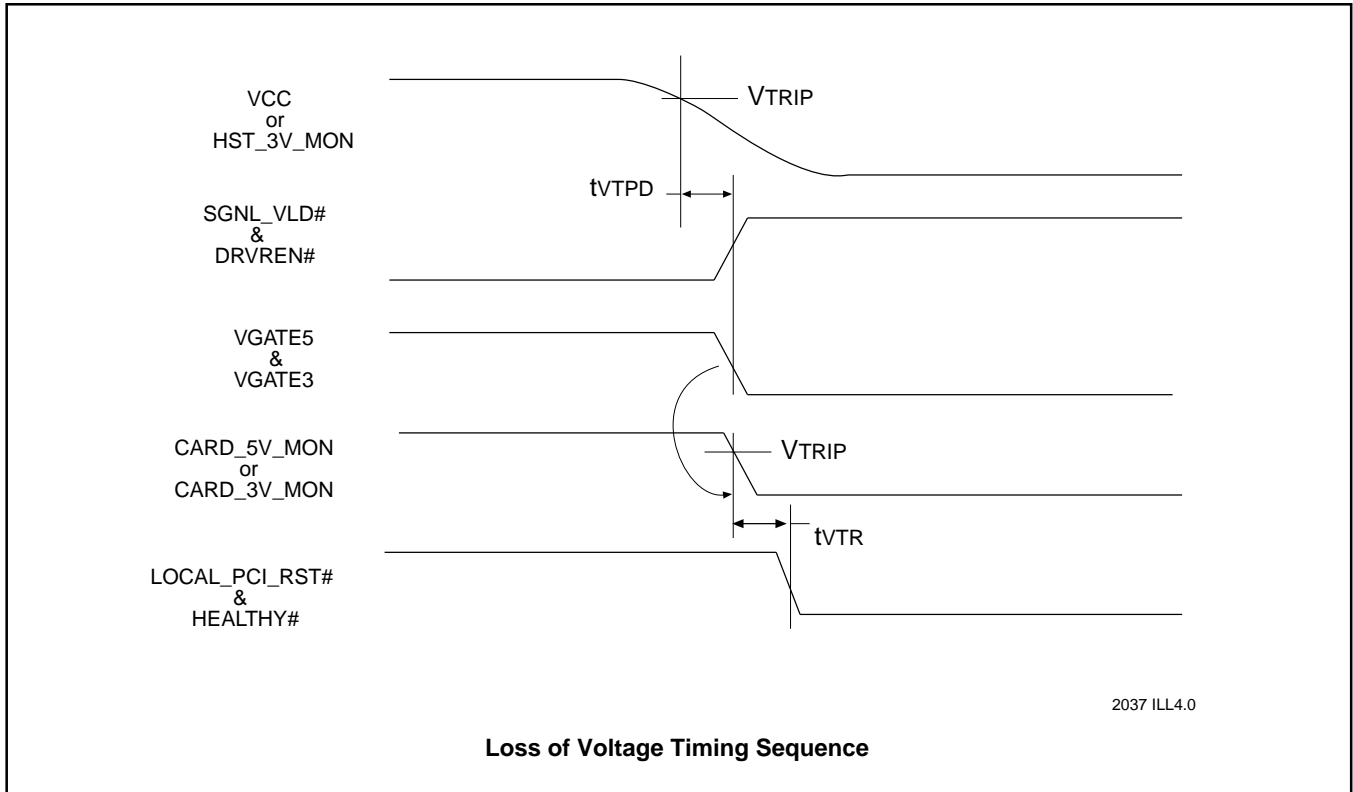



## MEMORY AC OPERATING CHARACTERISTICS

T<sub>A</sub> = -40°C to +85°C

Symbol	Parameter	Conditions	2.7V to 4.5V		4.5V to 5.5V		Units
			Min	Max	Min	Max	
fSCL	SCL Clock Frequency		0	100	0	400	KHz
tLOW	Clock Low Period		4.7		1.3		μs
tHIGH	Clock High Period		4.0		0.6		μs
tBUF	Bus Free Time	Before New Transmission	4.7		1.3		μs
tSU:STA	Start Condition Setup Time		4.7		0.6		μs
tHD:STA	Start Condition Hold Time		4.0		0.6		μs
tSU:STO	Stop Condition Setup Time		4.7		0.6		μs
tAA	Clock Edge to Valid Output	SCL low to Valid SDA (cycle n)	0.3	3.5	0.2	0.9	nμs
tDH	Data Out Hold Time	SCL low (cycle n+1) to SDA change	0.3		0.2		μs
tR	SCL and SDA Rise Time			1000		300	ns
tF	SCL and SDA Fall Time			300		300	ns
tSU:DAT	Data In Setup Time		250		100		ns
tHD:DAT	Data In Hold Time		0		0		ns
TI	Noise Filter SCL & SDA	Noise Suppression		100		100	ns
tWR	Write Cycle Time			5		5	ms

2037 PGM T5.1

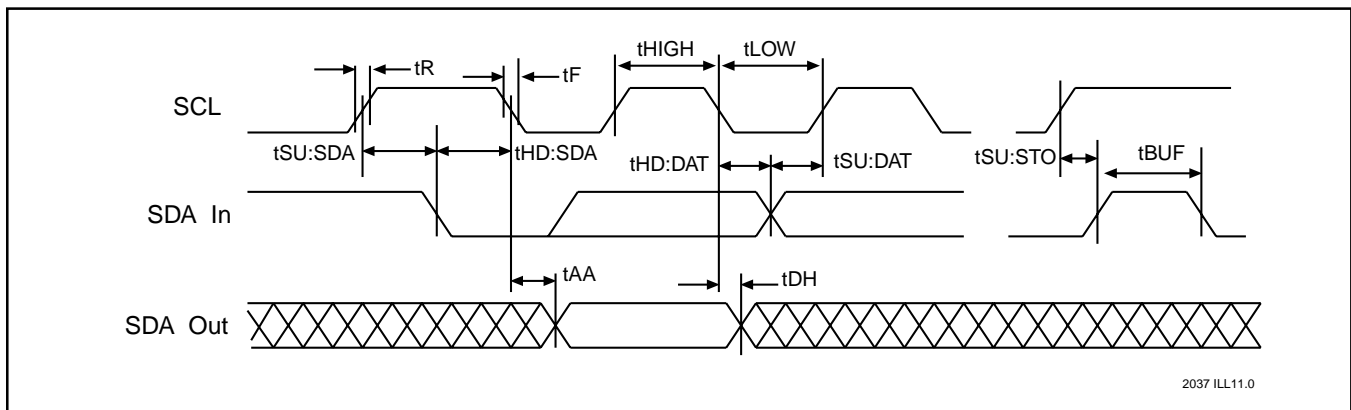

2037 ILL11.0

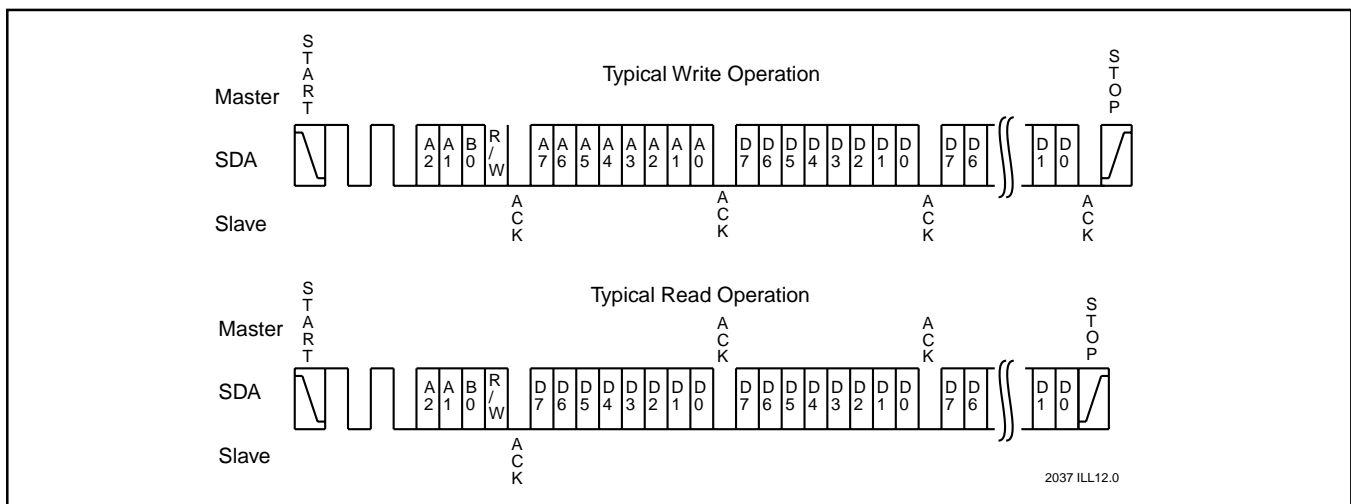

2037 ILL12.0



## PIN DESCRIPTIONS

**CBI\_5:** CBI\_5 is the circuit breaker input for the supply voltage. With a series resistor placed in the supply path between the 5V early power and CBI\_5, the circuit breaker will trip whenever the voltage across the resistor exceeds 50mV.

**DRVREN#:** DRVREN# is an open-drain, active-low output that indicates the status of the 3 volt and 5 volt high side driver outputs (VGATE5 and VGATE3). This signal may also be used as a switching signal for the 12 volt supply.

**FAULT#:** FAULT# is an open-drain, active-low output. It will be driven low whenever an over-current condition is detected. It will be reset at the same time that the VGATE outputs are turned back on after a reset from the host on the PWR\_EN pin.

**1Vref:** The 1Vref output provides a 1 volt reference for pre-charging the bus signal pins. Implementing a simple unity-gain amplifier circuit will allow pre-charging a large number of pins.

**ISLEW:** ISLEW is a Diode-connected NFET input. It may be used to adjust the 250V/s default slew rate of the high-side driver outputs

**VSEL:** VSEL is a TTL level input used to determine which of the host power supply inputs will be monitored for valid voltage and reset generation. This is a static input and the pin should be tied to V<sub>CC</sub> or ground through a resistor.

VSEL-Voltage Select	Host Voltage Monitored
Low	5 Volt or Mixed-Mode
High	3.3 Volt Only

**A0:** Address 0 is not used by the memory array. It can be connected to ground or left floating. It must not be connected V<sub>CC</sub>.

**A1, A2:** Address inputs 1 and 2 are used to set the two-bit device address of the memory array. The state of these inputs will determine the device address for the memory if it is on a two-wire bus with multiple memories with the same device type identifier. (For complete addressing information refer to the detailed memory operation section that follows.)

**SCL:** The SCL input is used to clock data into and out of the memory array. In the write mode, data must remain stable while SCL is HIGH. In the read mode, data is clocked out on the falling edge of SCL.

**SDA:** The SDA pin is a bidirectional pin used to transfer data into and out of the memory array. Data changing from one state to the other may occur only when SCL is LOW, except when generating START or STOP conditions. SDA is an open-drain output and may be wire-ORed with any number of open-drain outputs.

**BD\_SEL1# BD\_SEL2#:** These are active low TTL level inputs with internal pull-ups to V<sub>CC</sub>. When pulled low they indicate full board insertion. When used in a “non-High Availability” application these inputs will be the last connector pins to make contact with the host backplane. On the host side, the signals should be directly tied to ground. In a “High Availability” application these inputs can be the last pins to mate with the backplane. Alternatively, they can be actively driven by the host or be connected to switches interfaced to the board ejectors or any combination. Regardless, **BOTH** inputs **MUST** be low before the SMH4042 will begin to turn on the backend voltage.

**GND:** Ground should be applied at the same time as early-power.

**HEALTHY#:** HEALTHY# is an open-drain, active-low output indicating card side power inputs are above their reset trip levels.

**SGNL\_VLD#:** SGNL\_VLD# is an open-drain, active-low output that indicates card side power is valid and the internal card side PCI\_RST# timer has timed out.

**PWR\_EN:** PWR\_EN is a TTL level input that allows the host to enable or disable the power to the individual card. During initial power up, this signal would start in a low state and then be driven high during software initialization. If this signal is driven low, the power supply control outputs will be driven into the inactive state, and the reset signals asserted. In a “non-High Availability” system this input can be tied high.

The PWR\_EN input is also used to reset the SMH4042 circuit breakers. After an over-current condition is detected the VGATE outputs can be turned back on by first taking PWR\_EN low then returning it high.

**PCI\_RST#:** PCI\_RST# is a TTL level input used as a reset input signal from the host interface. A high to low transition (held low longer than 40ns) will initiate a reset sequence. The LOCAL\_PCI\_RST# output and the RESET output will be driven active for a minimum period of tPURST. If the PCI\_RST# input is held low longer than tPURST the reset outputs will continue to be driven until PCI\_RST# is released.



**LOCAL\_PCI\_RST#:** LOCAL\_PCI\_RST# is an open-drain active-low output. It is used to reset the backend circuitry on the add-in card. It is active whenever the card-side monitor inputs are below their respective  $V_{TRIP}$  levels. It may also be driven low by a low input on the PCI\_RST# pin.

**LOCAL\_PCI\_RST:** LOCAL\_PCI\_RST is an open-drain (PFET) active-high output. It operates in parallel with LOCAL\_PCI\_RST# providing an active high reset signal which is required by many 8051 style MCUs. It is active whenever the card-side monitor inputs are below their respective  $V_{TRIP}$  levels. It may also be driven active by a low input on the PCI\_RST# pin.

**CARD\_3V\_MON:** The CARD\_3V\_MON input monitors the card-side 3.3V supply. If the input falls below  $V_{TRIP}$ , the HEALTHY# and SIGNAL\_VLD# outputs are de-asserted and the reset outputs are driven active.

**VGATE3:** VGATE3 is a slew rate limited high side driver output for the 3.3V external power FET gate. The VGATE3 output-voltage is generated by an on-board charge pump.

**HST\_3V\_MON:** The HST\_3V\_MON input monitors the host 3.3 volt supply and it is used as a reference for the circuit breaker comparator. If VCC3 falls below  $V_{TRIP}$ , SIGNAL\_VLD# is de-asserted, the high side drivers are disabled and LOCAL\_PCI\_RST# is asserted.

**CBI\_3:** CBI\_3 is the circuit breaker input for the low supply. With a series resistor placed in the supply path between VCC3 and CBI\_3, the circuit breaker will trip whenever the voltage across the resistor exceeds 50mV.

**CARD\_5V\_MON:** The CARD\_5V\_MON input monitors the card-side 5V supply. If the input falls below  $V_{TRIP}$ , the HEALTHY# and SIGNAL\_VLD# outputs are de-asserted and the reset outputs are driven active.

**VGATE5:** VGATE5 is a slew rate limited high side driver output for the 5V external power FET gate. The output voltage is generated by an on-board charge pump.

**Vcc:** Vcc is the power supply pin for the SMH4042 This input is monitored for power integrity. If it falls below the 5V sense threshold ( $V_{TRIP}$ ) and the VSEL input is low, the SIGNAL\_VLD# HEALTHY# signals are de-asserted, the high side drivers disabled and reset outputs are

asserted. On a **CompactPCI** board, this must be connected to early power.

## DEVICE OPERATION

### Power-Up Sequence

The SMH4042 is an integrated power controller for any hot swappable add-in card. The SMH4042 provides all the signals and control functions to be compatible with **CompactPCI** Hot Swap requirements for basic hot swap systems, full hot swap boards and high availability systems.

### Insertion Process

As the add-in board is inserted into the backplane physical connections should be made with the chassis in order to properly discharge any voltage potentials to ground. The board will first contact the long pins on the backplane that provide early power (+5V, +3.3V and ground). Depending upon the board configuration early power should be routed to the VCC pin of the SMH4042. As soon as power is applied, the SMH4042 will assert the reset outputs to the backend circuits, turn off the VGATE3/5 outputs (disabling the external power FETS) and begin outputting the 1-volt Vref. The 1-volt reference can be used to pre-charge the I/O pins before they begin to mate with the bus signals. The open collector HEALTHY# output will be de-asserted, It should be actively pulled high by an external pull-up resistor (minimum 10K ohm).

The next pins to mate are the I/Os and the balance of the power pins, if they are not already mated. The I/Os will have been pre-charged by the Vref output of the SMH4042.

The BD\_SEL# pins are the last inputs to be driven to their true state. In most systems these will most likely be driven to ground when the short pins are mated. This would indicate the card is fully inserted and the power-up sequence can begin. If, however, the design is based on high availability requirements the two pins can be actively driven by the host or combined with a switch input indicating the ejector handles are fully engaged.

### Sequencing

Once the proper card insertion has been assured, the SMH4042 will check the status of the Power Enable signal from the host. This input can be used to power down individual cards on the bus via software control; it must be held high in order for the SMH4042 to enable power sequencing to the card.

Once these conditions are met, the SMH4042 will drive the VGATE3 and VGATE5 outputs to turn on the external 3 volt and 5 volt power FETs. The slew rate of these outputs is controlled using on board circuitry and results in a slew rate of 250V/s. Different slew rates can be



accommodated by either adding an additional capacitor between the MOSFET gate and ground or by injecting current into the ISLEW input. All circuitry on the card is held in a reset condition until the 5 volts (or 3.3 volt) supply is stable and the reset interval timer has timed out the 150ms reset time. At this point, the reset signals are de-asserted, and proper operation of the card commences.

The SMH4042 will monitor the card's backend voltages. Once they are at or above the CARD VTRIP levels, the SMH4042 will drive the HEALTHY# output.

### Card Removal Process

The card removal process operates in the opposite sequence. For non-high-availability cards, the action of card removal disconnects the BD\_SEL# (short pins) from ground and the SMH4042 will instantly shutdown the VGATE outputs, change the HEALTHY# status and assert the LOCAL\_PCI\_RST# output.

Because connectors to the host backplane employ the staggered pins, power will still be applied to the SMH4042 and the I/O interface circuits. The LOCAL\_PCI\_RST# signal will place the interface circuits into a high impedance condition. The pre-charge voltage will be applied to the I/Os enabling a graceful disengagement from the active bus. Once the I/O pins are free of the backplane power can then be removed from the SMH4042 and other early power devices by releasing the long pins.

The removal process is slightly different for a high-availability system. As the ejector handle is rotated the ejector switch will open, causing a change of state that will activate the ENUM# signal to the host. In response to this notification the host will de-assert a hardware controlled BD\_SEL# signal. This action will turn on an indicator LED on the card, notifying the operator it is now safe to proceed with the removal of the card. The sequence will then follow that outlined for the non-high-availability removal process.

### Power Configurations

The SMH4042 can be used in 5V-only, 3.3V-only and mixed voltage systems. For mixed voltage systems, simply connect the appropriate bus and card power inputs as indicated. The VSEL pin should be grounded.

For systems with a single power supply, connect VCC and HST\_3V\_MON together to the bus power line. Also connect CARD\_3V\_MON and CARD\_5V\_MON together to the card side power. Now the state of VSEL determines

the reset level that will be used to signal valid power. For 3.3V systems, tie VSEL to VCC, for 5V systems, tie VSEL to ground.

## MONITORING POWER SUPPLY HEALTH

### Monitor Inputs

The SMH4042 has a total of six comparators that are used to monitor the health of the host platform supplies and the card-side (backend) voltages. In hot swap applications each supply going to the backend logic needs to be monitored at three points.

The first point is at the source on the host connector, VCC and HST\_3V\_MON. If this voltage is not within specification, then the down stream sequencing of powering-on the backend logic will not proceed.

The next stage (the CBI inputs) is one step closer to the backend logic to monitor the current flowing into the backend logic. This can not exceed the specification; however, if it does, then the SMH4042 must turn off the source to the backend logic.

The CARD\_5V\_MON and CARD\_3V\_MON inputs are used to sense the actual voltage level in the backend logic. If either comparator detects a low voltage condition the backend logic will be placed in a reset condition (LOCAL\_PCI\_RST# asserted), but the VGATE outputs will remain active so long as the host voltage and current sense are valid.

### VCC vs. HST\_3V\_MON

The VCC input is the supply input and in a CompactPCI application this pin must connect to an early power pin on the host connector. The HST\_3V\_MON input is strictly a voltage monitoring input, it is not a supply input. The operating supply voltage range on the VCC pin is 2.7V to 5.5V, but it will only monitor a 5V supply. This is not an



issue with a dual supply application. But in a single supply application these two pins must be shorted and VSEL conditioned as explained above.

### Programmable Vtrip Thresholds

The host voltage monitors and the backend voltage monitors are programmable (by the factory) and provide a number of options to the end user. The  $V_{CC}$  monitor  $V_{TRIP}$  level can be selected for either a 5% or 10% supply with default values of 4.25V or 4.625V. The HST\_3V\_MON  $V_{TRIP}$  level can be programmed to 2.65V, 2.8V, 2.95V and 3.1V.

The CARD\_V\_MON thresholds are set in relation to their corresponding host voltage monitor thresholds. The offset can either be +50mV or -50mV. This allows the designer to select (+50mV) if they want a collapse in the backend voltage to trigger a local reset condition prior to the host supply collapsing and powering down the board without warning. Alternatively they can choose (-50mV) to trigger a board shutdown based on the host power supply falling out of spec.

### Over-current Circuit Breaker

The SMH4042 provides a circuit breaker function to protect against short circuit conditions or exceeding the supply limits. By placing a series resistor between the host supply and the CBI pins, the breakers will trip whenever the voltage drop across the series resistor is greater than 50mV for more than 16 $\mu$ s.

The over-current detection circuit was designed to maximize protection while minimizing false alarms. The most critical period of time is during the power-on sequence when the backend circuits are first being energized. If the card has a faulty component or shorted traces the time to shut off should be minimal. However, if the board has been operational for a long period of time the likelihood of a catastrophic failure occurring is quite low. Therefore, the SMH4042 employs two different sampling schemes.

During power-up the device will sample the current every 500ns. If eight consecutive overcurrent conditions are detected the VGATE outputs will immediately be shut

down. This provides an effective response time of 4 $\mu$ s. During normal operation, after the FETs have been turned on, the sampling rate will be adjusted to 2 $\mu$ s, thus providing an effective response time of 16 $\mu$ s.

### Reset Control

While in the power sequencing mode, the reset outputs are the last to be released. When they are released all conditions of a successful power-up sequence must have been met.

**$V_{CC}$  and HST\_3V\_MON are at or above their respective VTRIP levels**

+

**BD-SEL# inputs are true**

+

**CARD\_3V\_MON and CARD\_5V\_MON inputs are at or above their respective trip levels**

+

**PWR\_EN input is pulled high**

+

**PCI\_RST# is high**

The PCI-RST# input must be high for the reset outputs to be released. Assuming all of the conditions listed above have been met and PCI\_RST# is high and  $t_{PURST}$  has expired, a low input of greater than 40ns duration on the PCI\_RST# input will initiate a reset cycle. The duration of the reset cycle will be determined by the PCI\_RST# input.

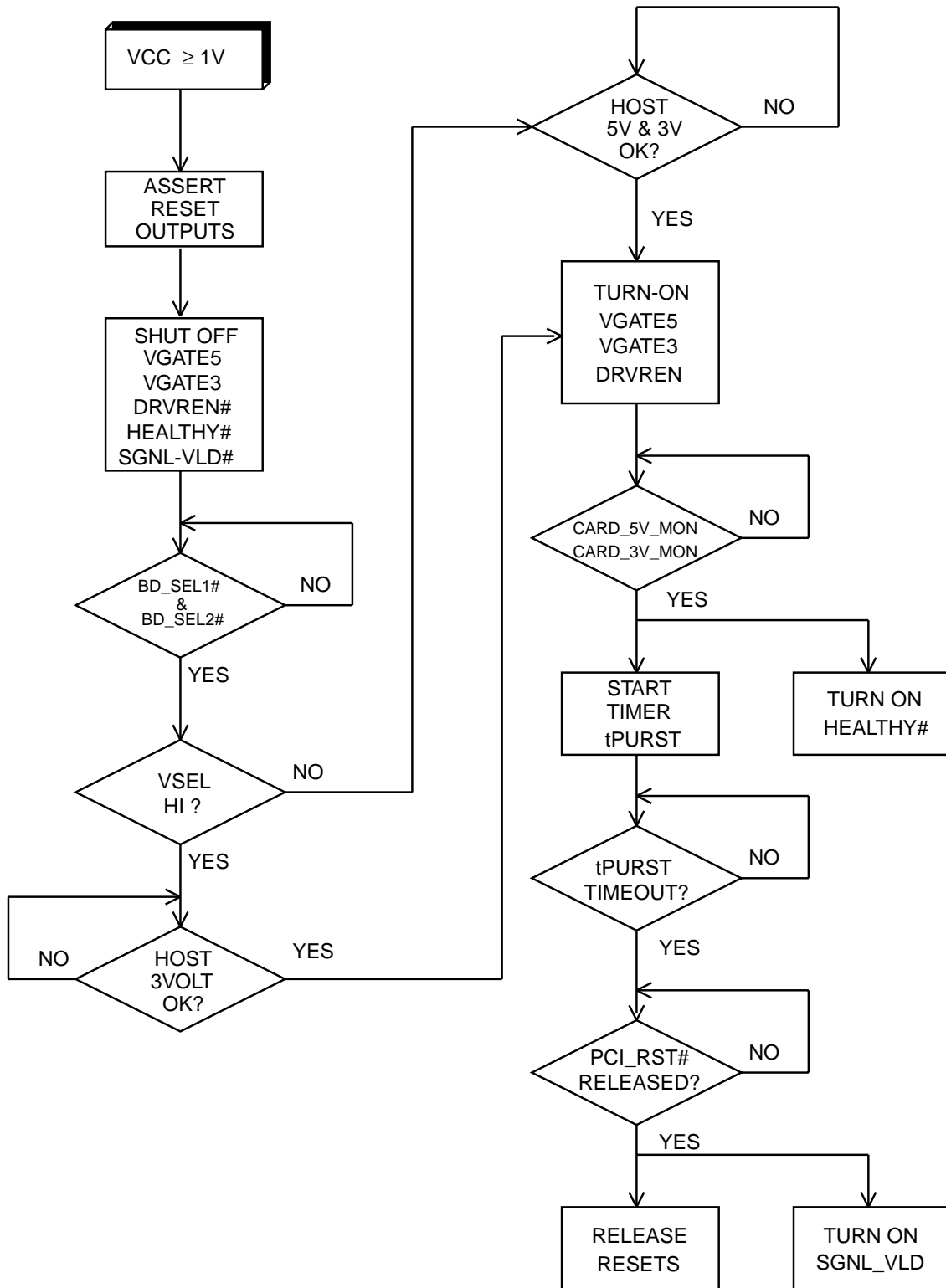

2037 ILL14.2

Figure 1. Sequence Flow Diagram



## MEMORY OPERATION

The SMH4042 memory is configured as a 512 x 8 array. Data are read and written via an industry standard two-wire interface. The bus was designed for two-way, two-line serial communication between different integrated circuits. The two lines are a serial data line (SDA), and a serial clock line (SCL). The SDA line must be connected to a positive supply by a pull-up resistor, located somewhere on the bus

### Input Data Protocol

The protocol defines any device that sends data onto the bus as a “transmitter” and any device that receives data as a “receiver.” The device controlling data transmission is called the “master” and the controlled device is called the “slave.” In all cases, the SMH4042 will be a “slave” device, since it never initiates any data transfers.

One data bit is transferred during each clock pulse. The data on the SDA line must remain stable during clock HIGH time, because changes on the data line while SCL is HIGH will be interpreted as start or stop condition.

### START and STOP Conditions

When both the data and clock lines are HIGH, the bus is said to be not busy. A HIGH-to-LOW transition on the data line, while the clock is HIGH, is defined as the “START” condition. A LOW-to-HIGH transition on the data line, while the clock is HIGH, is defined as the “STOP” condition.

### Acknowledge (ACK)

Acknowledge is a software convention used to indicate successful data transfers. The transmitting device, either the master or the slave, will release the bus after transmitting eight bits. During the ninth clock cycle, the receiver will pull the SDA line LOW to ACKnowledge that it received the eight bits of data.

The SMH4042 will respond with an ACKnowledge after recognition of a START condition and its slave address byte. If both the device and a write operation are selected, the SMH4042 will respond with an ACKnowledge after the receipt of each subsequent 8-bit word. In the READ mode, the SMH4042 transmits eight bits of data, then releases the SDA line, and monitors the line for an ACKnowledge signal. If an ACKnowledge is detected, and no STOP condition is generated by the master, the SMH4042 will continue to transmit data. If an ACKnowledge is not detected, the SMH4042 will terminate further data transmissions and awaits a STOP condition before returning to the standby power mode.

## Device Addressing

Following a start condition the master must output the address of the slave it is accessing. The most significant four bits of the slave address are the device type identifier (see below). For the SMH4042 this is fixed as 1010[B]. The next two bits select one of four possible devices on the bus. The state of the hardwired inputs (A2 and A1) correspond to the serial bit stream A2 and A1 in the slave address. The next bit is the block select bit, effectively the MSB of the byte address.

### Read/Write Bit

The last bit of the data stream defines the operation to be performed. When set to “1,” a read operation is selected; when set to “0,” a write operation is selected.

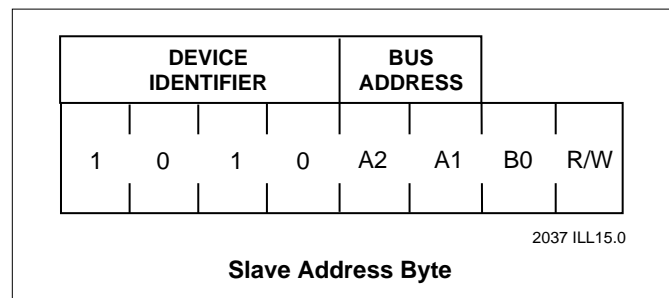

## WRITE OPERATIONS

The SMH4042 allows two types of write operations: byte write and page write. A byte write operation writes a single byte during the nonvolatile write period (tWR). The page write operation allows up to 16 bytes in the same page to be written during tWR.

### Byte Write

After the slave address is sent (to identify the slave device, and a read or write operation), a second byte is transmitted which contains the 8 bit address of any one of the 512 words in the array. Upon receipt of the word address, the SMH4042 responds with an ACKnowledge. After receiving the next byte of data, it again responds with an ACKnowledge. The master then terminates the transfer by generating a STOP condition, at which time the SMH4042 begins the internal write cycle. While the internal write cycle is in progress, the SMH4042 inputs are disabled, and the device will not respond to any requests from the master.

### Page Write

The SMH4042 is capable of a 16-byte page write operation. It is initiated in the same manner as the byte-write operation, but instead of terminating the write cycle after the first data word, the master can transmit up to 15 more bytes of data. After the receipt of each byte, the SMH4042 will respond with an ACKnowledge.



The SMH4042 automatically increments the address for subsequent data words. After the receipt of each word, the low order address bits are internally incremented by one. The high order bits of the address byte remain constant. Should the master transmit more than 16 bytes, prior to generating the STOP condition, the address counter will “roll over,” and the previously written data will be overwritten. As with the byte-write operation, all inputs are disabled during the internal write cycle. Refer to Figure 5 for the address, ACKnowledge and data transfer sequence.

### Acknowledge Polling

When the SMH4042 is performing an internal WRITE operation, it will ignore any new START conditions. Since the device will only return an acknowledge after it accepts the START, the part can be continuously queried until an acknowledge is issued, indicating that the internal WRITE cycle is complete. See the flow diagram below for the proper sequence of operations for polling.

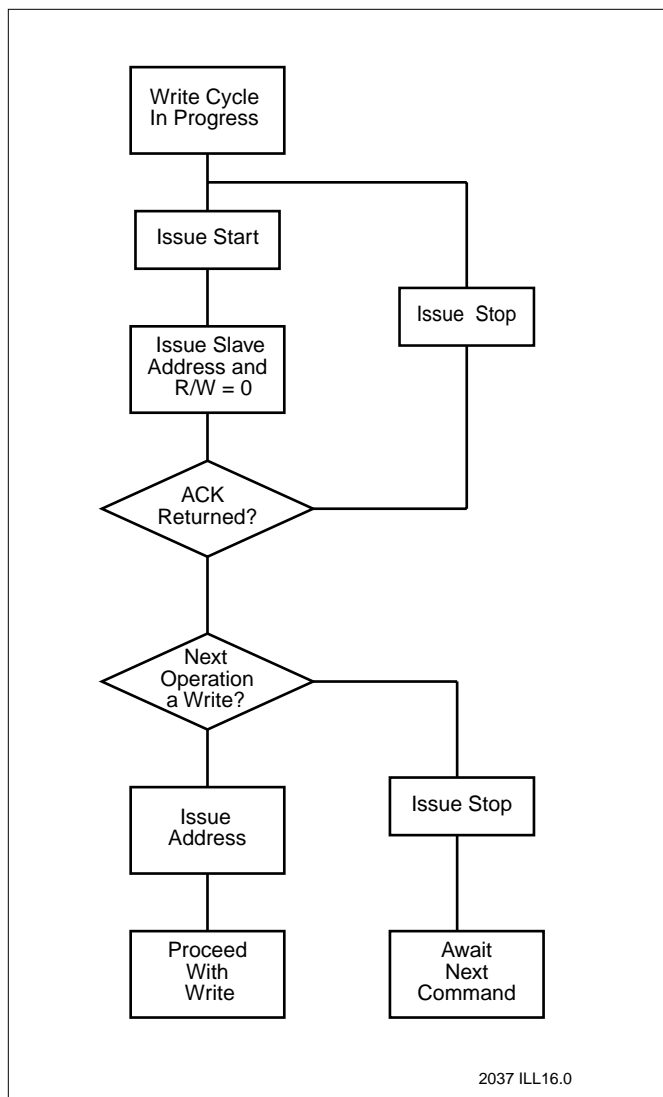

### READ OPERATIONS

Read operations are initiated with the R/W bit of the identification field set to “1.” There are two different read options:

1. Current Address Byte Read
2. Random Address Byte Read

#### Current Address Read

The SMH4042 contains an internal address counter which maintains the address of the last word accessed, incremented by one. If the last address accessed (either a read or write) was to address location n, the next read operation would access data from address location n+1 and increment the current address pointer. When the SMH4042 receives the slave address field with the R/W bit set to “1,” it issues an acknowledge and transmits the 8-bit word stored at address location n+1. The current address byte read operation only accesses a single byte of data. The master does not acknowledge the transfer, but does generate a stop condition. At this point, the SMH4042 discontinues data transmission.

#### Random Address Read

Random address read operations allow the master to access any memory location in a random fashion. This operation involves a two-step process. First, the master issues a write command which includes the start condition and the slave address field (with the R/W bit set to WRITE) followed by the address of the word it is to read. This procedure sets the internal address counter of the SMH4042 to the desired address. After the word address acknowledge is received by the master, the master immediately reissues a start condition followed by another slave address field with the R/W bit set to READ. The SMH4042 will respond with an acknowledge and then transmit the 8-data bits stored at the addressed location. At this point, the master does not acknowledge the transmission but does generate the stop condition. The SMH4042 discontinues data transmission and reverts to its standby power mode.



## **Sequential READ**

Sequential reads can be initiated as either a current address READ or random access READ. The first word is transmitted as with the other byte read modes (current address byte READ or random address byte READ); however, the master now responds with an ACKnowledge, indicating that it requires additional data from the SMH4042. The SMH4042 continues to output data for each ACKnowledge received. The master terminates the sequential READ operation by not responding with an ACKnowledge, and issues a STOP conditions. During a sequential read operation, the internal address counter is automatically incremented with each acknowledge signal. For read operations, all address bits are incremented, allowing the entire array to be read using a single read command. After a count of the last memory address, the address counter will 'roll-over' and the memory will continue to output data.

## **Data Download**

The SMH4042 supports a proprietary mode of operation specifically for the Hot Swap environment. After a power on reset the internal address pointer is reset to 00. The host or ASIC then only needs to issue a read command and then sequentially clock out data starting at address 00.



CompactPCI Applications Aid

Design Considerations for a CompactPCI Board

Figure 2 is a generic representation of a CompactPCI board and it illustrates how the SMH4042 is the key component in the board insertion/removal process. The illustrations that follow show in more detail how the various blocks interface to the SMH4042.

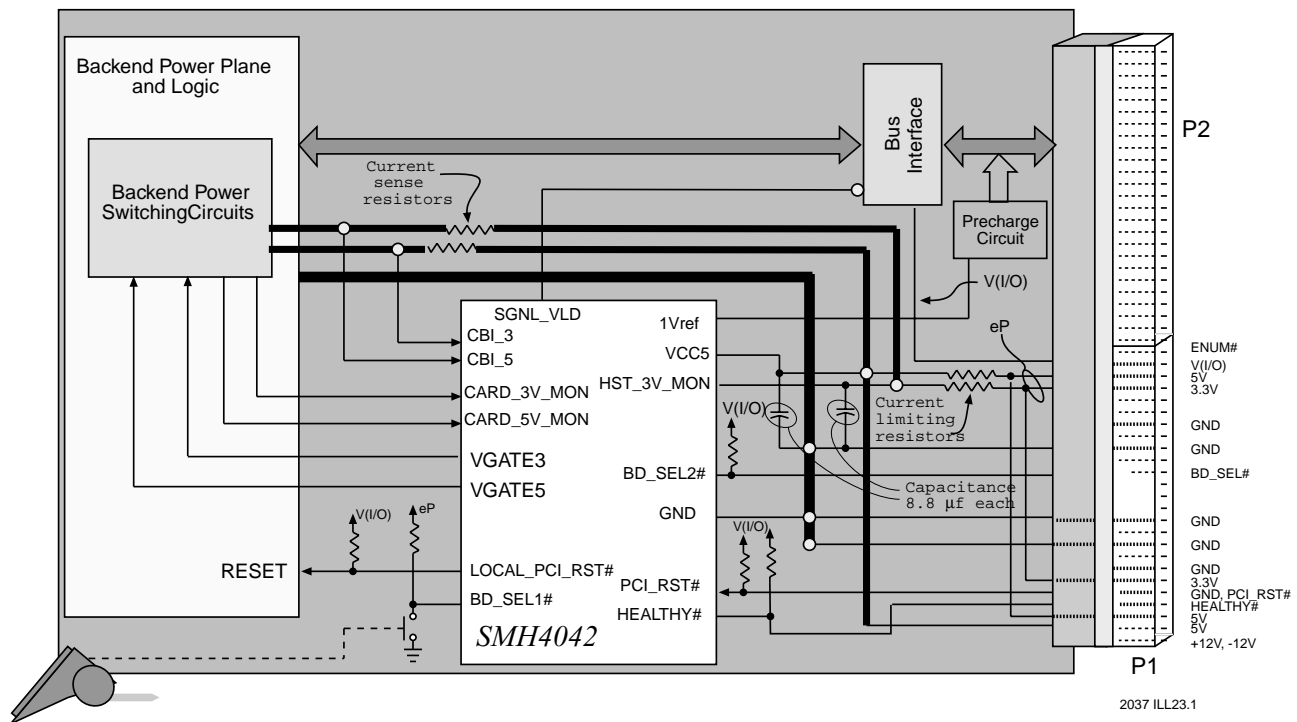

Figure 2. Block diagram of typical CompactPCI board.

Power Busses

It is important in the design of the board to insure the backend logic is isolated from the power control circuits and other early power circuits such as FPGAs and the I/O interface circuits. In the illustration shown below, the early power busses for +5V, +3V have series current limiting resistors. These values should be calculated so as to limit the in-rush current that will initially charge the capacitive load of the early power circuits. As the card is inserted further, the medium length pins engage and short out the current limiting resistors. Note the placement of the sense (shunt) resistors. They are in series with the power-FETs and no voltage drop will be detected across the resistor until VGATE is applied to the power-FETs. The sense resistor values are determined by dividing 50mV by the current spec for that supply.

It should be noted that there is an inherent delay from VGATE turning on to VGATE3 turning on. The typical delay is illustrated in Figure 4.



CompactPCI Applications Aid

Figure 3. Power Control and Power Plane Isolation

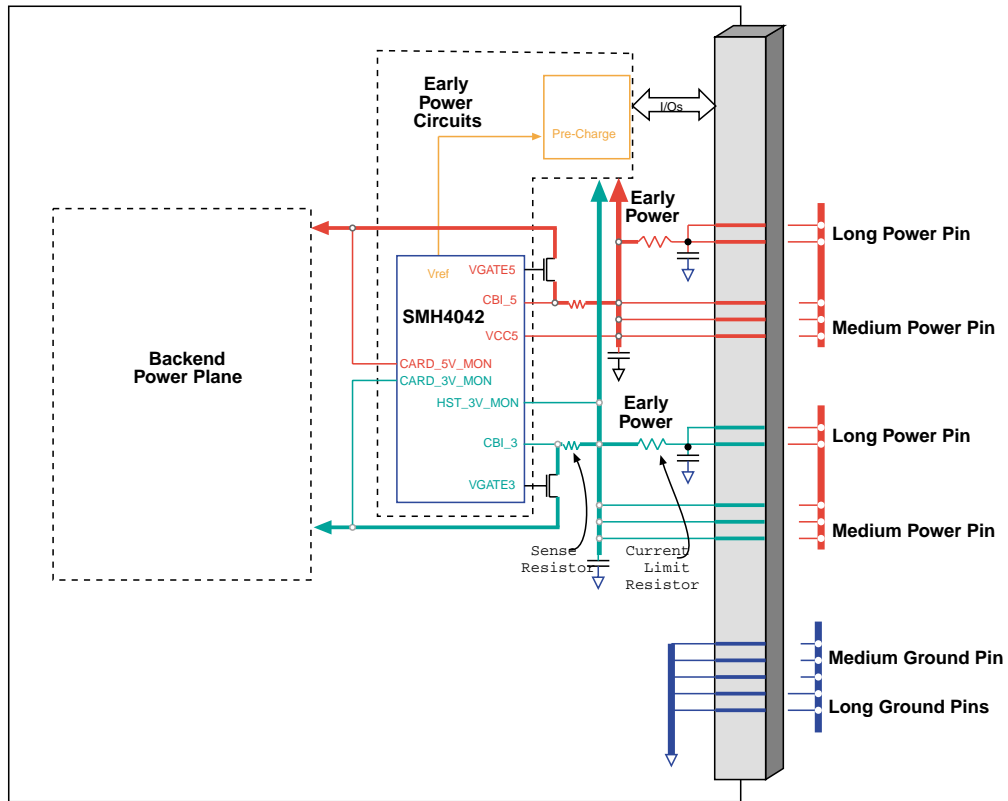

2037 ILL24.0

Figure 4. Typical delay between VGATE5 and VGATE3

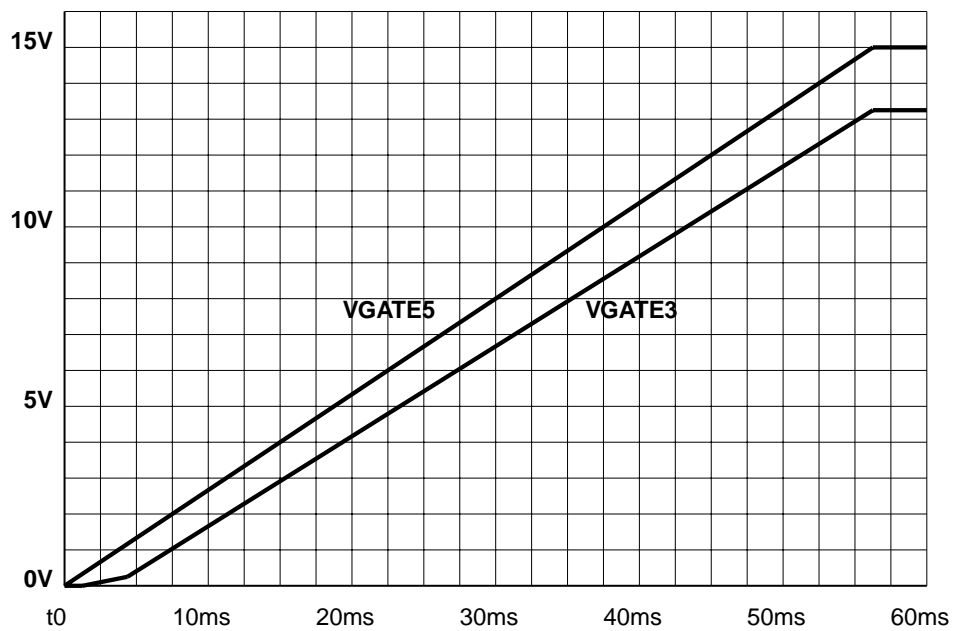

2037 ILL25.0



CompactPCI Applications Aid

Power Switching Options

The figures below illustrate four possible methods for wiring the SMH4042. In the first example both power-FETs are connected to a single VGATE output. This should be used when the design requires the backend voltages to be powered-up simultaneously. In the second example both VGATE outputs are being used so that the 3.3V slew lags the 5V slew. The two bottom circuits illustrate the wiring for single power supply boards. Note how the VSEL pin is biased differently for the two applications.

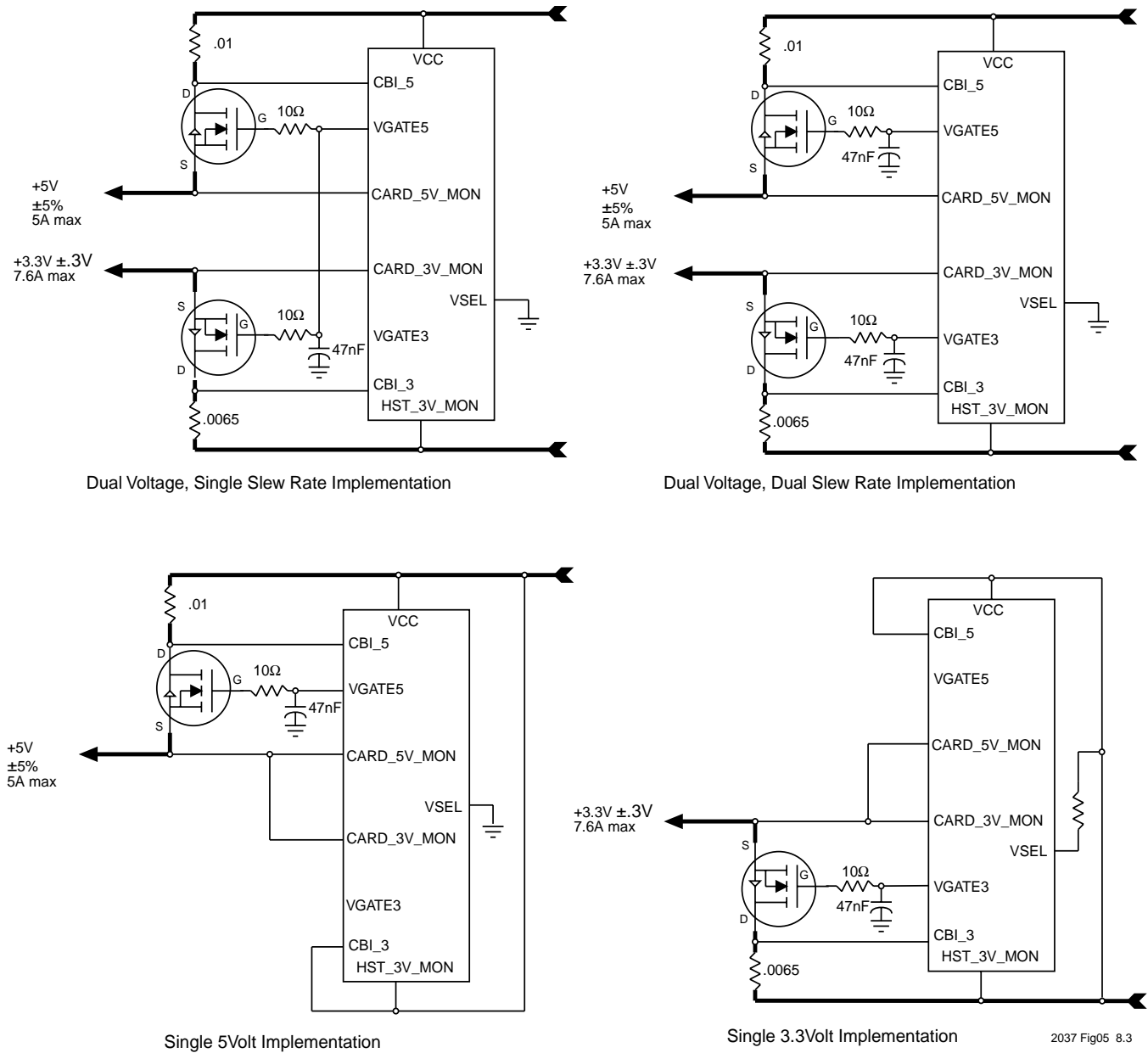

Figure 5. Four power switching implementations



CompactPCI Applications Aid

I/O Buffers

Depending upon the application requirements there are a number of silicon solutions that employ low on-resistance CMOS switches. Figure 6 shows one implementation using a QuickSwitch<sup>®</sup> from Quality Semiconductor. This particular device exhibits very Flat R<sub>ON</sub> characteristics from 0 to 5V. The only drawback is the extra space required for the external pull-up resistors.

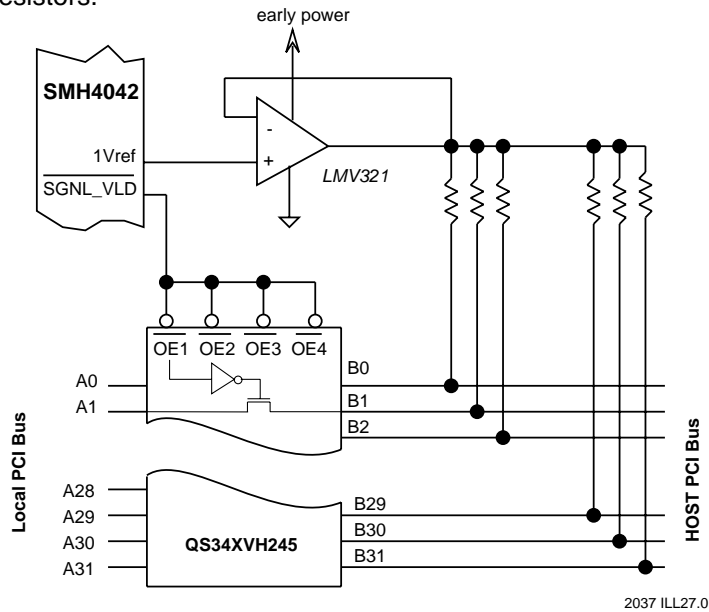

Figure 6. Bus buffers with external pull-ups

Figure 7 shows another implementation, but the pull-up resistor structure is incorporated in the switch. The circuit also automatically switches the bias voltage out of the circuit as the CMOS switches are enabled. A potential advantage is the ability to place the interface closer to the edge of the card. The board designer should evaluate their requirements and design goals and determine their best solution. The bus switches are available from both Texas Instruments and Pericom Semiconductor.

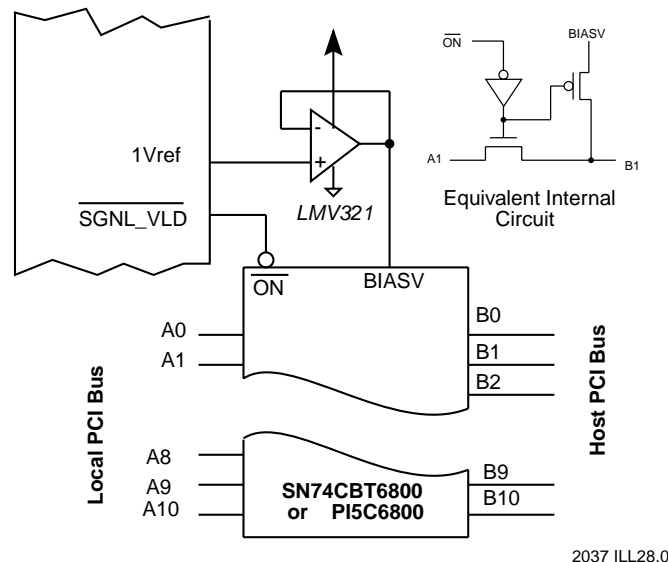

Figure 7. Bus buffers with integrated pull-ups



CompactPCI Applications Aid

**I/O Pre-charge**

The CompactPCI specs require the add-in board to pre-charge the board's I/Os before making contact with bus pins and the pre-charge voltage is 1V ±0.1V. The SMH4042 provides an accurate 1volt reference output that is accurate and stable prior to the medium length pins making contact. The 1Vref output should be the reference input to a unity gain op amp circuit. Figure 8 is a typical implementation utilizing a common op amp.

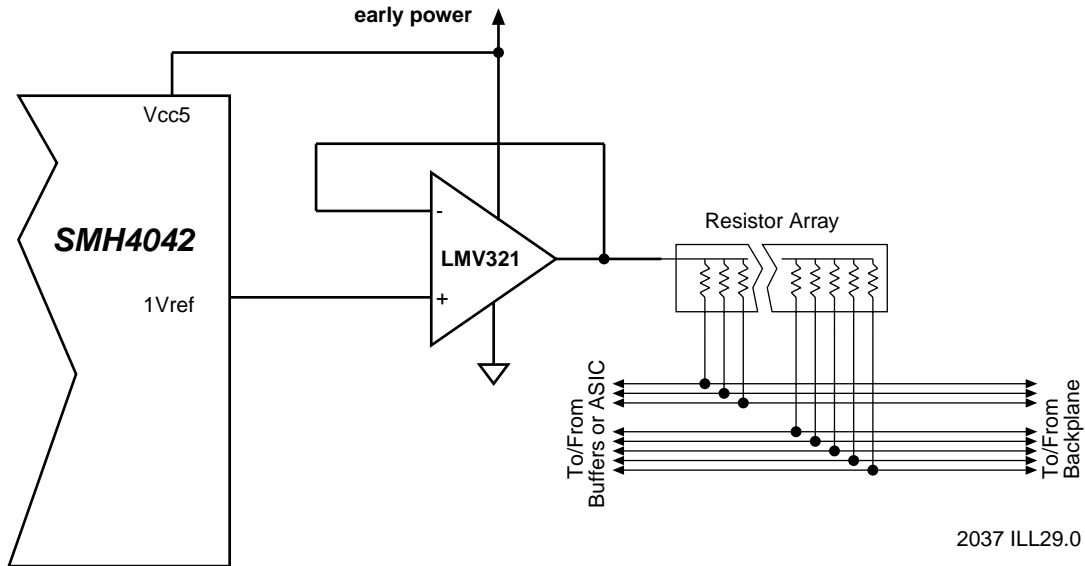

2037 ILL29.0

Figure 8. I/O pre-charge circuit

**Special Considerations**

The example application shown in Figure 2 shows both of the BD\_SEL inputs being used independently. These two inputs are effectively AND'ed internally and they must both be low before any sequencing will proceed. In most design cases the BD\_SEL1# connection to an injector switch is redundant and realistically can be grounded.

The CompactPCI Hot Swap spec does provide a mechanism for implementing high availability systems using "Full Hot Swap" boards. This capability entails integrating the injector/ejector handle, the blue LED and a board status signal. Section 2.3.2 of the **CompactPCI** Hot Swap spec states the following.

- "A signal (ENUM#) is provided to notify the system host that either a board has been freshly inserted or is about to be extracted."
- "A switch, actuated with the lower ejector handle of the board, is used to signal the insertion or impending extraction of a board."
- "A blue LED, located on the from to the board is illuminated when it is permissible to extract a board."

Figure 8 illustrates a possible implementation of the circuits needed. It should be noted this will require the implementation of a status register that works in conjunction with the switch logic to generate the ENUM# signal. Notice the blue LED circuit and the active high reset output used to activate a current boost circuit for the LED. The sequence of operations is as follows:



CompactPCI Applications Aid

- **The long pins engage.**
  - Power is supplied to the SMH4042, the LED and the BD\_SEL” pull-up resistor.
  - V(I/O) is either the early 5V or the early 3V, dependent upon the interface operating levels.
  - The LED is illuminated by LOCAL\_PCI\_RST# going low.
- **The medium length pins contact.**
  - The ENUM# signal should **not be** active at this point.
- **The board is fully inserted and the injector switch is closed.**
  - ENUM# is driven low.
  - BD\_SEL# makes contact (optional: the pull-up on the board indicates to the host the presence of a board.)
  - The host responds to the ENUM# signal and drives BD\_SEL# low.
  - This provides the last gating item to the SMH4042 before it will begin the power-on sequence.

Switching + and -12Volts

In some applications there may be a need to switch + or -12Volts to the backend circuits. Using the SMH4042 DRVREN# output these voltages can be controlled as shown in the Figure 9 below:

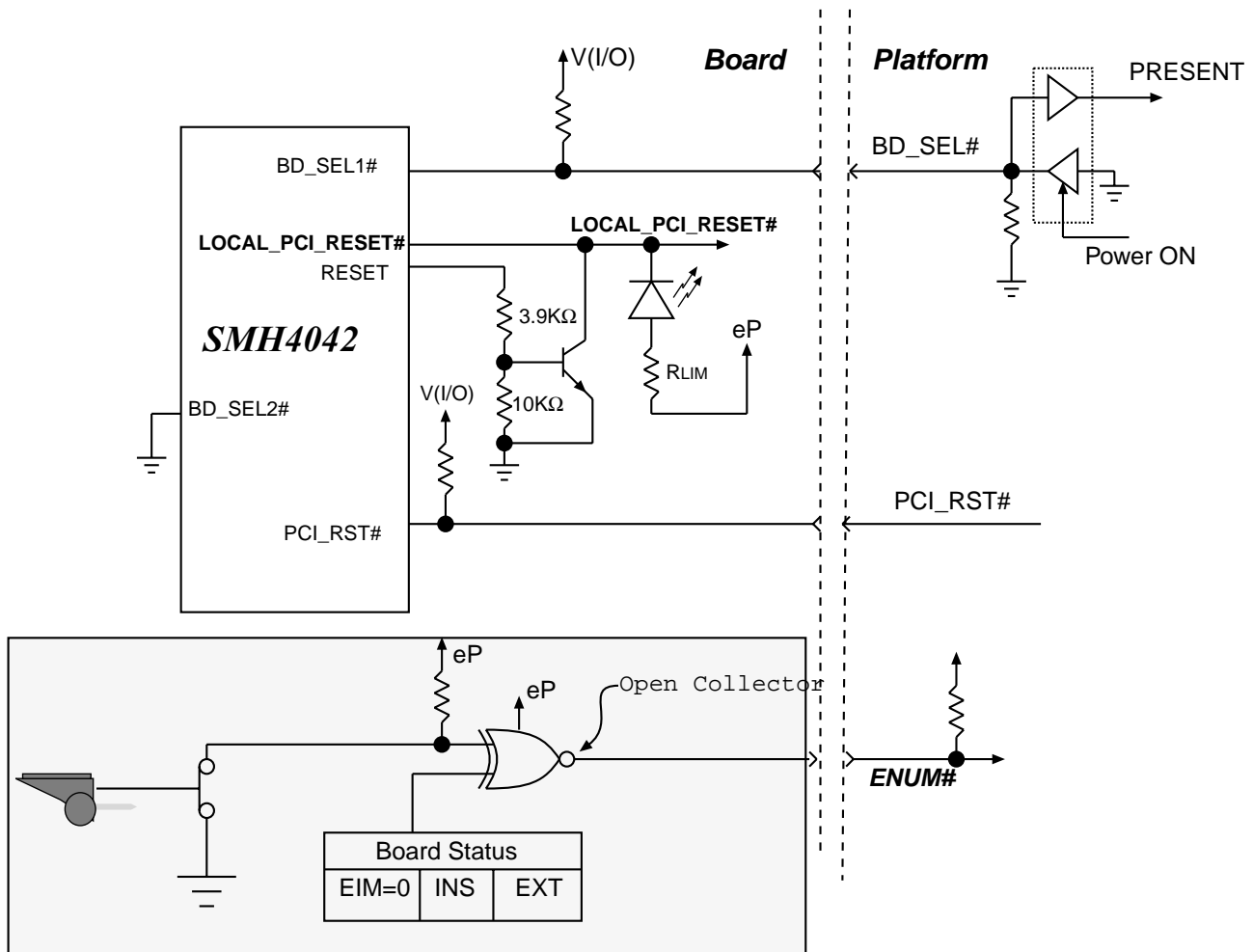

2037 ILL30.0

Figure 9. Full HotSwap board/host interface



## CompactPCI Applications Aid

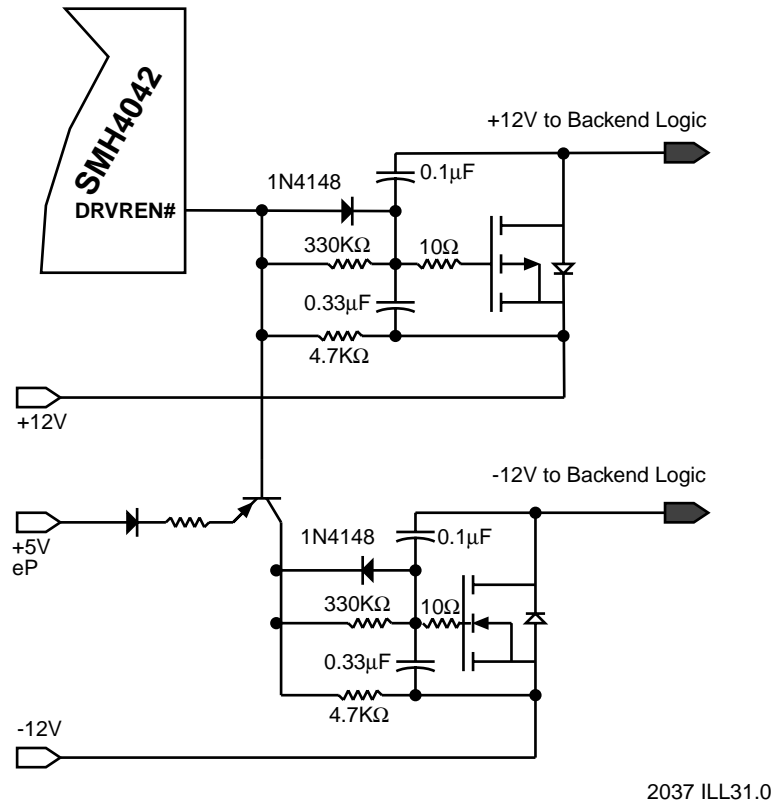

Figure 10. Using DRVREN# to switch + and -12V to the backend logic

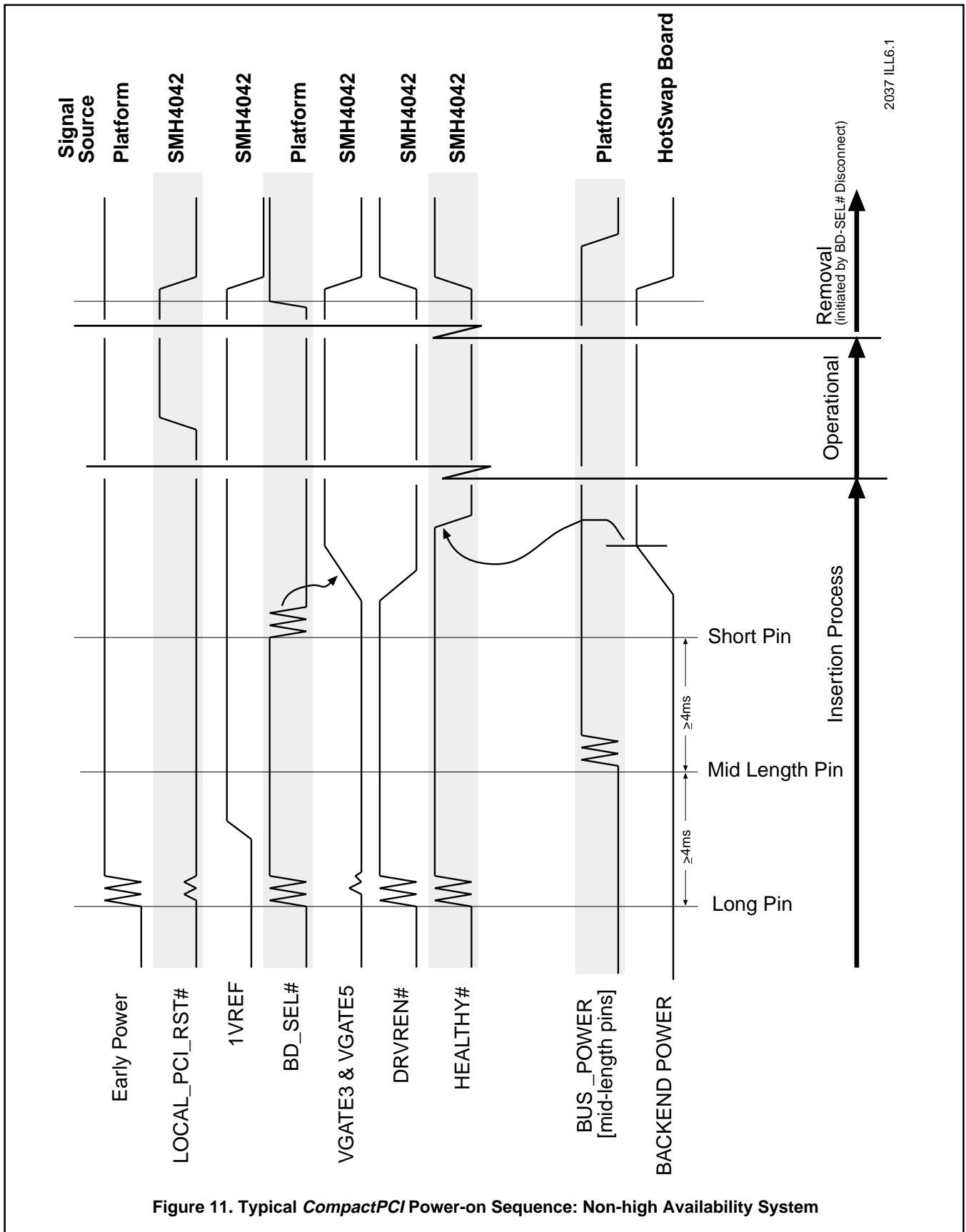

Figure 11. Typical CompactPCI Power-on Sequence: Non-high Availability System

2037 ILL6.1

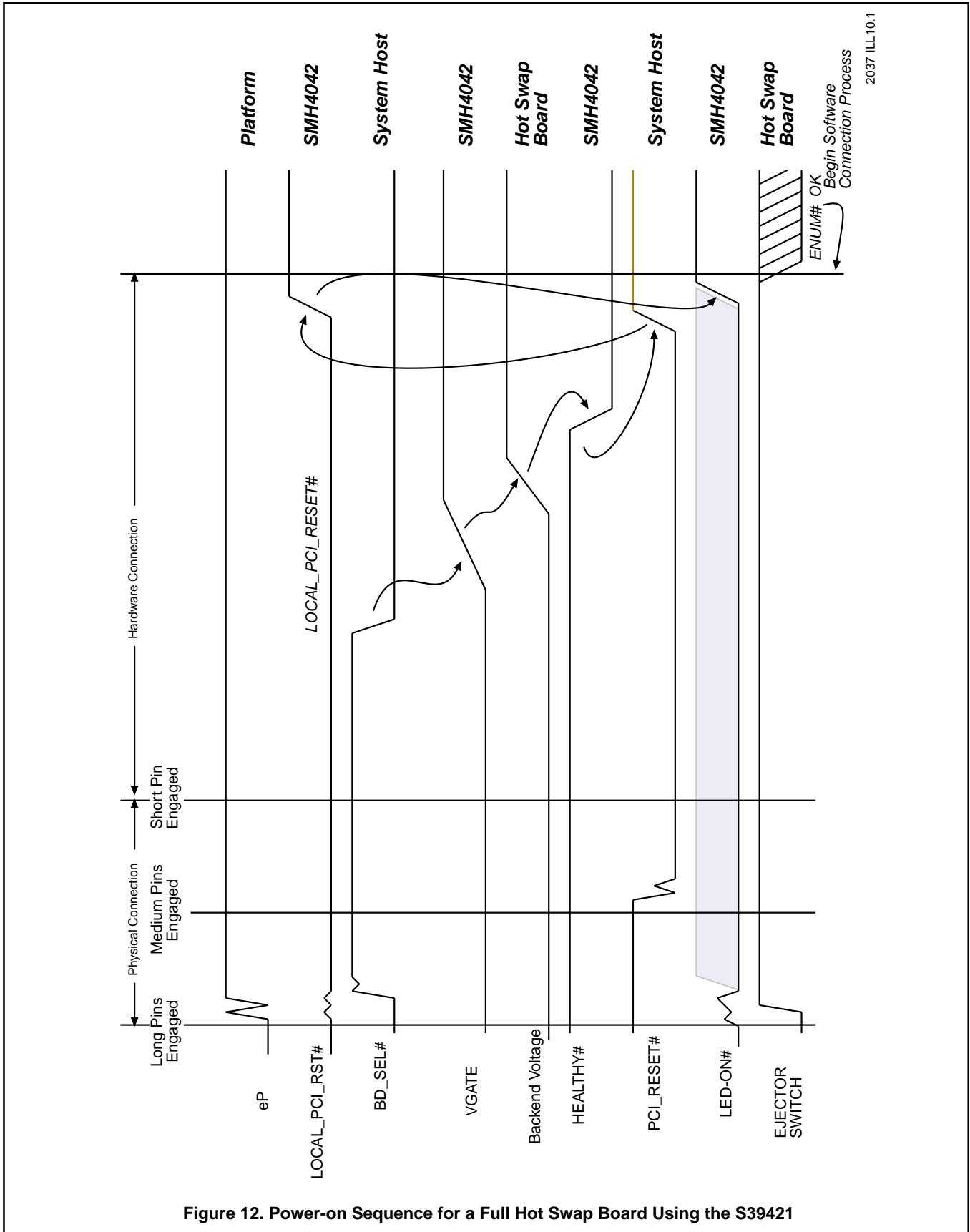

Figure 12. Power-on Sequence for a Full Hot Swap Board Using the S39421

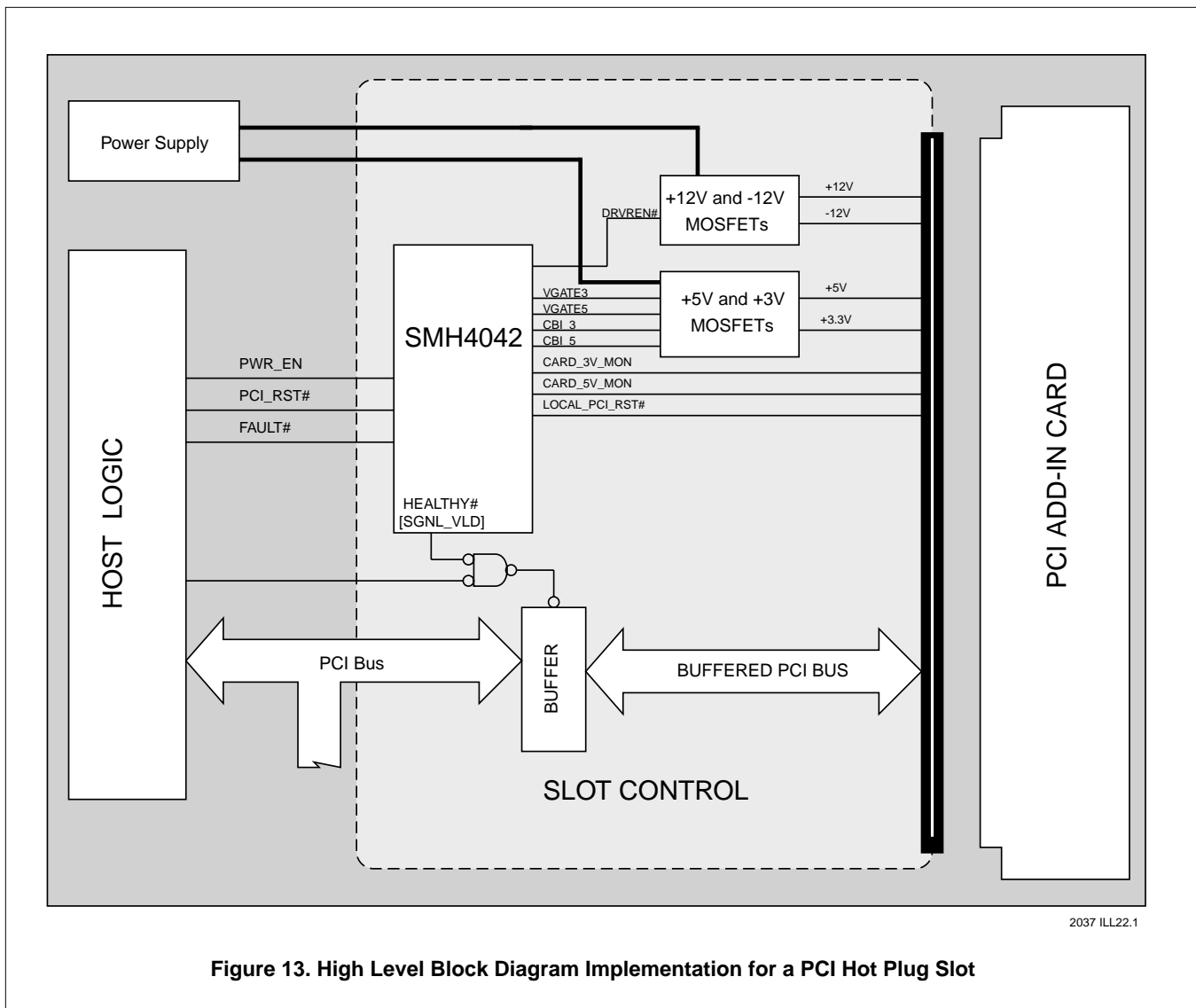
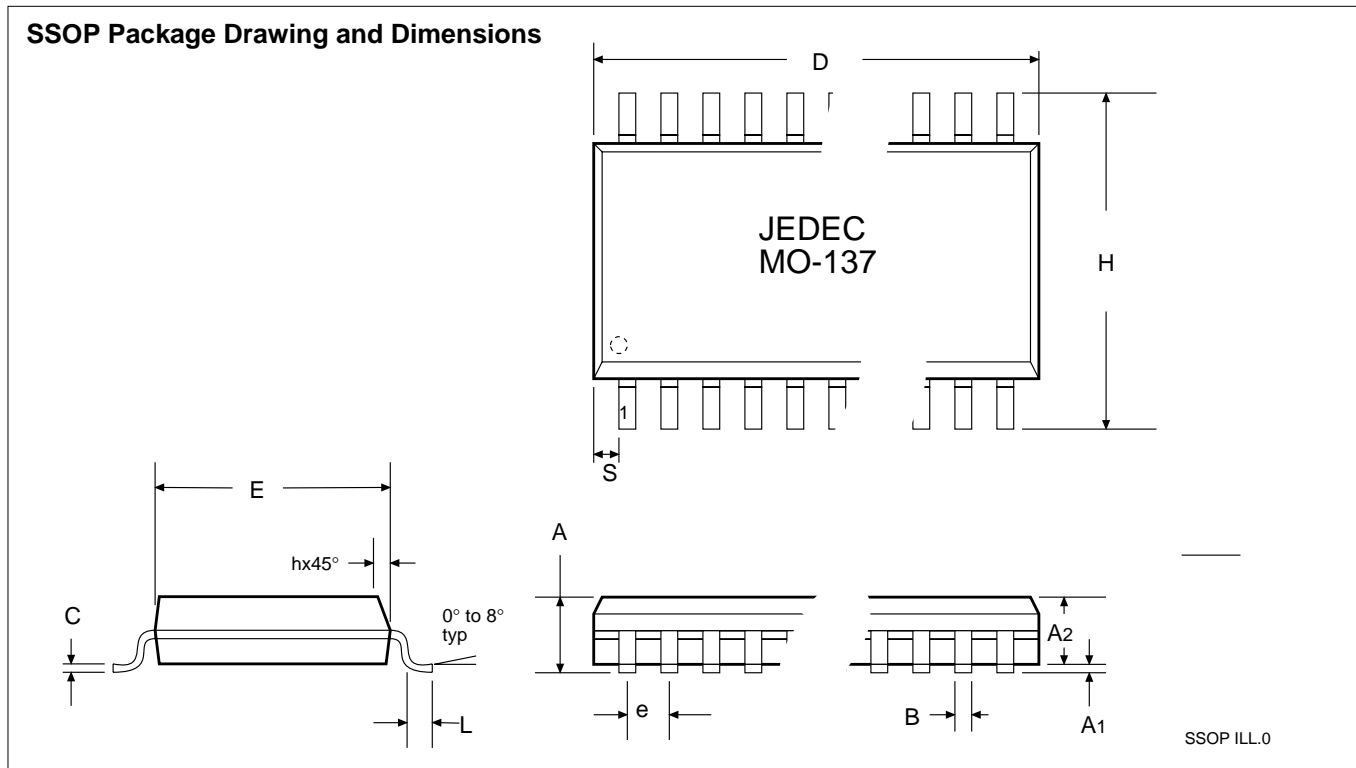

Figure 13. High Level Block Diagram Implementation for a PCI Hot Plug Slot

Although the primary application for the SMH4042 is as a voltage controller for **CompactPCI** or VME boards, it is versatile enough to be used as a Hot Plug controller on a host PCI card. The functional blocks are similar to those of the **CompactPCI** implementation but they are now resident on the motherboard. The same circuits shown for switching the voltages on the card can also be used for controlling the slot voltages.



**This Table in Inches**

	Common dimensions			Pin Count	Dimension "D"			Dimension "S"		
	Min	Nom	Max		Min	Nom	Max	Min	Nom	Max
A	.061	.064	.068	16	.189	.194	.196	.0020	.0045	.0070
A1	.004	.006	.0098	20	.337	.342	.344	.0500	.0525	.0550
A2	.055	.058	.061	24	.337	.342	.344	.0250	.0275	.0300
B	.008	.010	.012	28	.386	.391	.393	.0250	.0280	.0300
C	.0075	.008	.0098							
D	See Variations									
E	.150	.155	.157							
e	.025BSC									
H	.230	.236	.244							
h	.010	.013	.016							
L	.016	.025	.035							
N	Pin Count									
S	See Variations									

**This Table in Millimeters**

	Common dimensions			Pin Count	Dimension "D"			Dimension "S"		
	Min	Nom	Max		Min	Nom	Max	Min	Nom	Max
A	1.55	1.63	1.73	16	4.80	4.93	4.98	0.05	0.11	0.18
A1	0.12	0.15	0.25	20	8.56	8.69	8.74	1.27	1.33	1.40
A2	1.40	1.47	1.55	24	8.56	8.69	8.74	0.64	0.70	0.76
B	0.20	0.25	0.31	28	9.80	9.93	9.98	0.64	0.71	0.76
C	0.19	0.20	0.25							
D	See Variations									
E	3.81	3.94	3.99							
e	0.635 BSC									
H	5.84	5.99	6.20							
h	0.25	0.33	0.41							
L	0.41	0.64	0.89							
N	Pin Count									
S	See Variations									



## 28-Lead Small Outline Package (SOIC)

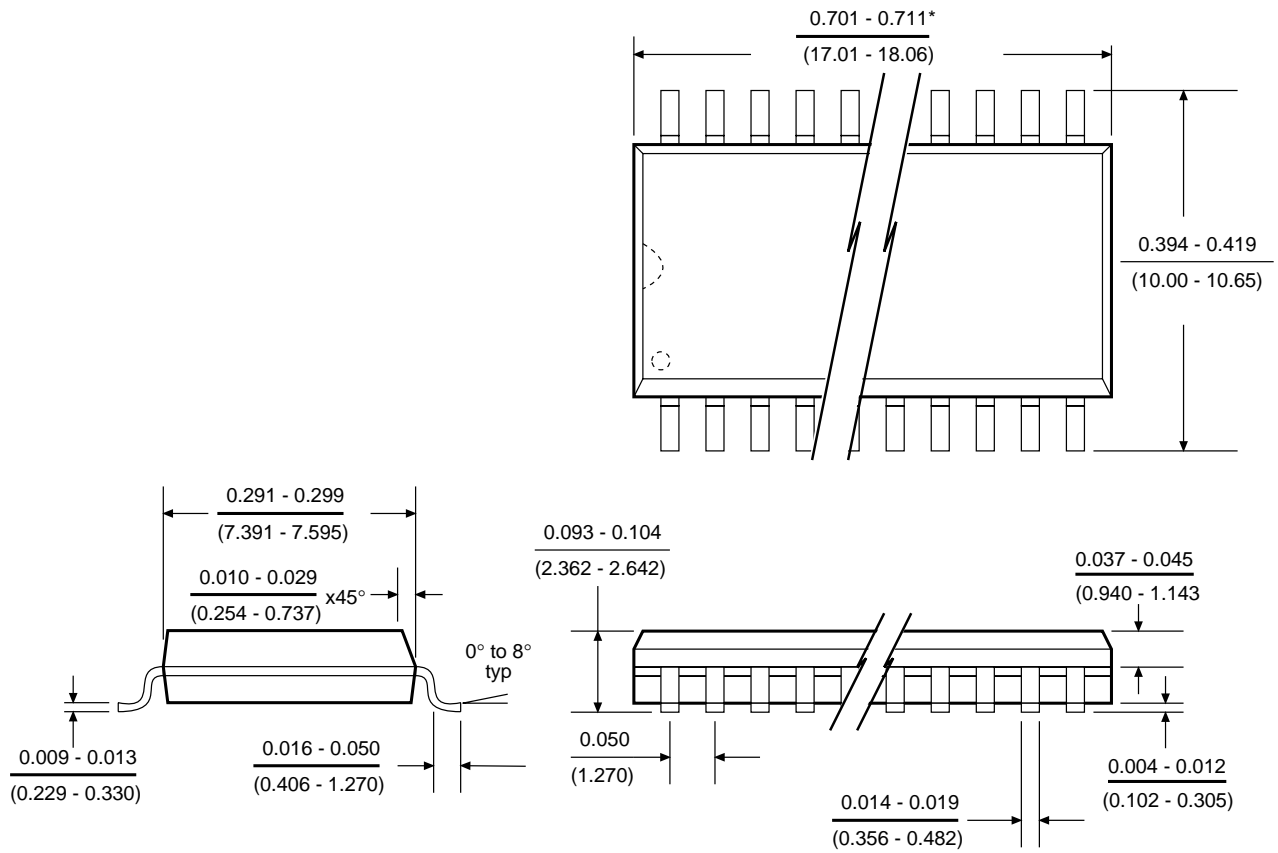

28pn SOIC ILL.1



## ORDERING INFORMATION

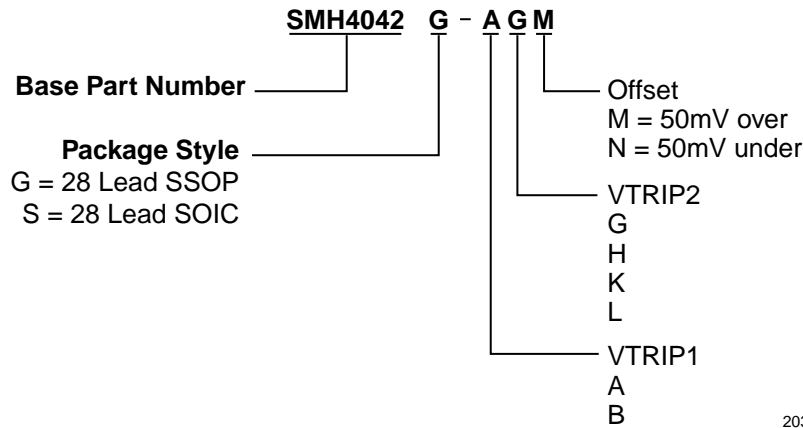

2037 ILL17.3

## VALID ORDERING COMBINATIONS

Package	Vtrip1	Vtrip2	Offset
G	A	G	M
G	A	G	N
G	A	H	M
G	A	H	N
G	A	K	M
G	A	K	N
G	B	G	M
G	B	G	N
G	B	H	M
G	B	H	N
G	B	K	M
G	B	K	N
G	B	L	M
G	B	L	N

Package	Vtrip1	Vtrip2	Offset
S	A	G	M
S	A	G	N
S	A	H	M
S	A	H	N
S	A	K	M
S	A	K	N
S	B	G	M
S	B	G	N
S	B	H	M
S	B	H	N
S	B	K	M
S	B	K	N
S	B	L	M
S	B	L	N

Note: Contact the factory for information regarding "AL" Vtrip availability.



## NOTICE

SUMMIT Microelectronics, Inc. reserves the right to make changes to the products contained in this publication in order to improve design, performance or reliability. SUMMIT Microelectronics, Inc. assumes no responsibility for the use of any circuits described herein, conveys no license under any patent or other right, and makes no representation that the circuits are free of patent infringement. Charts and schedules contained herein reflect representative operating parameters, and may vary depending upon a user's specific application. While the information in this publication has been carefully checked, SUMMIT Microelectronics, Inc. shall not be liable for any damages arising as a result of any error or omission.

SUMMIT Microelectronics, Inc. does not recommend the use of any of its products in life support or aviation applications where the failure or malfunction of the product can reasonably be expected to cause any failure of either system or to significantly affect their safety or effectiveness. Products are not authorized for use in such applications unless SUMMIT Microelectronics, Inc. receives written assurances, to its satisfaction, that: (a) the risk of injury or damage has been minimized; (b) the user assumes all such risks; and (c) potential liability of SUMMIT Microelectronics, Inc. is adequately protected under the circumstances.

HotSwap™ is a trademark of Summit Microelectronics, Inc.  
PICMG™ & CompactPCI™ are trademarks of PCI Industrial Computer Manufacturers' Group.  
I<sup>2</sup>C™ is a trademark of Philips Corporation.