

**Six-Channel Supply Monitor and Sequencing Controller**
**FEATURES & APPLICATIONS**

- Monitors and Controls up to 6 Power Supplies
- Programmable Sequencing for both Power-on and Power-off
- Programmable Threshold Sensors
- Programmable Reset and Interrupt Functions
- Programmable Watchdog/Longdog Timer
- Fault and Status Registers
- 4k-Bit Nonvolatile Memory

**Applications**

- Monitor and Control Distributed Power and Point of Use Power Supplies
  - Telecom
  - Compact PCI
  - Servers
- Multi-voltage Network Processors, DSPs, ASICs

**INTRODUCTION**

The SMS64 is a highly integrated power supply monitor and controller. The SMS64 has six supply managers, each individually programmable with regard to threshold voltages, actions that can be taken with either an under- or over-voltage condition and how that manager will operate in sequencing the power-on operation.

The managers can act independently or sequenced with any other manager in the device. When the managers work together the device can control the sequence in which power is applied to the application circuits. Each manager is assigned to a sequence position which allows the device to perform power supply sequencing in any order. For power-off situations the SMS64 can sequence the supplies either in the same order or reverse order from the power-on sequence.

The SMS64 has two programmable Watchdog timers, two programmable reset outputs and a programmable IRQ# output. Using the I<sup>2</sup>C 2-wire serial interface, a host system can communicate with the SMS64 status register, optionally control power-on via software and utilize 4 K-bits of nonvolatile memory.

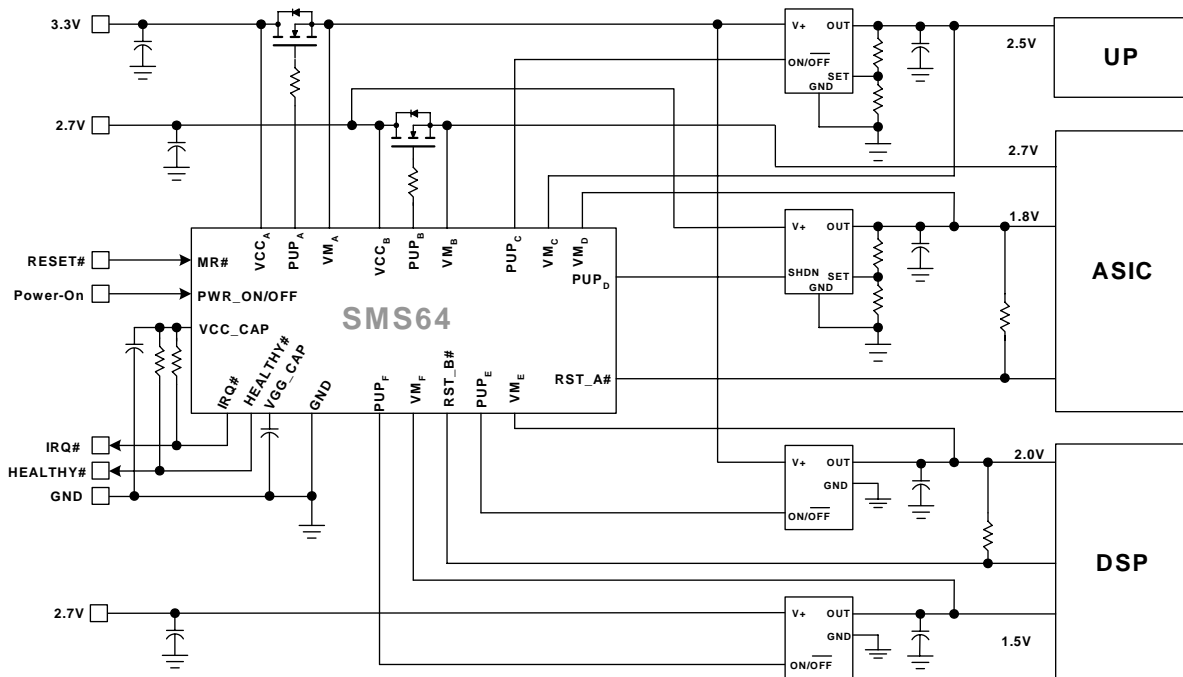
**SIMPLIFIED APPLICATIONS DRAWING**

**Power Supply Sequencing and System Start-up Initialization using the SMS64**

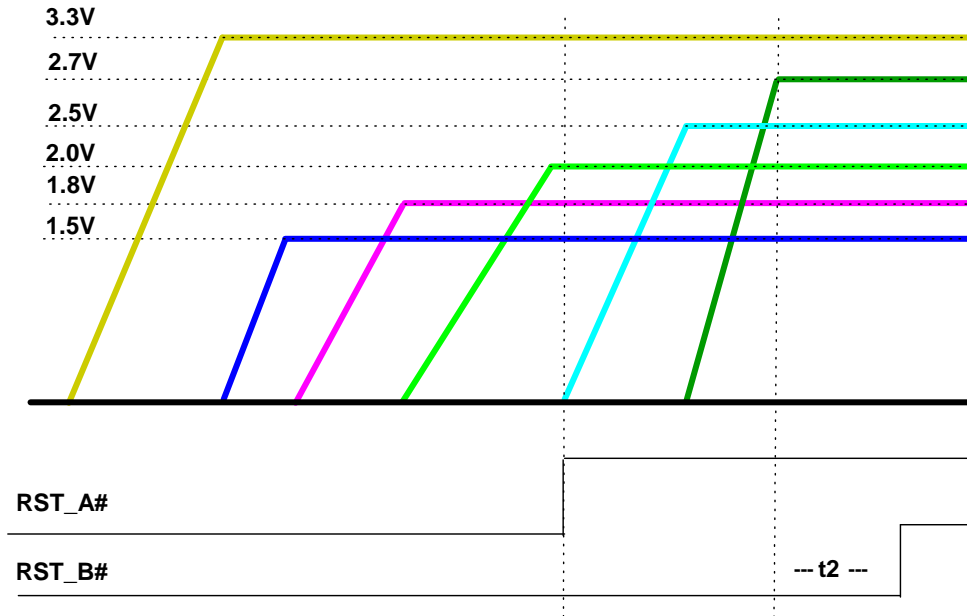
This is an example application and the specific component values are purposely not shown. The SMS64 can be used with any combination of MOSFETs, LDOs or DC/DC converters to optimize sequencing and minimize losses in the power chain.



**Figure 1 – Example Power Supply Sequencing and System Start-up Initialization using the SMS64 as shown in the Simplified Applications Drawing on page 1. Any order of supply sequencing can be applied using the SMS64**

## GENERAL DESCRIPTION

The SMS64 has four major functional blocks; the supply managers and the sequencing outputs; the programmable reset and interrupt circuitry; the timing and control block; and the nonvolatile memory array.

The managers are comprised of a voltage monitor with a programmable threshold input. The monitored voltage threshold can be programmed anywhere between 0.9V and 6.0V in 20mV increments. Each monitor provides an under-voltage/over-voltage (UV/OV) signal to the internal bus.

Associated with each monitor is an output circuit (PUP circuit) that can be used to enable or switch an external power supply to the application's circuits. The point in time and position in a sequence when the output is asserted is programmable and is controlled by the sequence position assignments and the PUP delays in the timing and control block.

The other major block is a programmable reset and interrupt block. The SMS64 provides a great deal of flexibility in choosing the trigger source for the resets and interrupt. The sources include multiple combinations of UV/OV conditions, and programmable Watchdog and Longdog timers.

Programming of the SMS64 is performed over the industry standard I<sup>2</sup>C, 2-wire serial data interface. It allows configuration of the device, real-time control of the power-on/power-off processes and instant-access to the power supply status of the application circuit. The bus interfaces the host to 4k bits of nonvolatile memory and the programmable configuration registers.



**FUNCTIONAL BLOCK DIAGRAM**

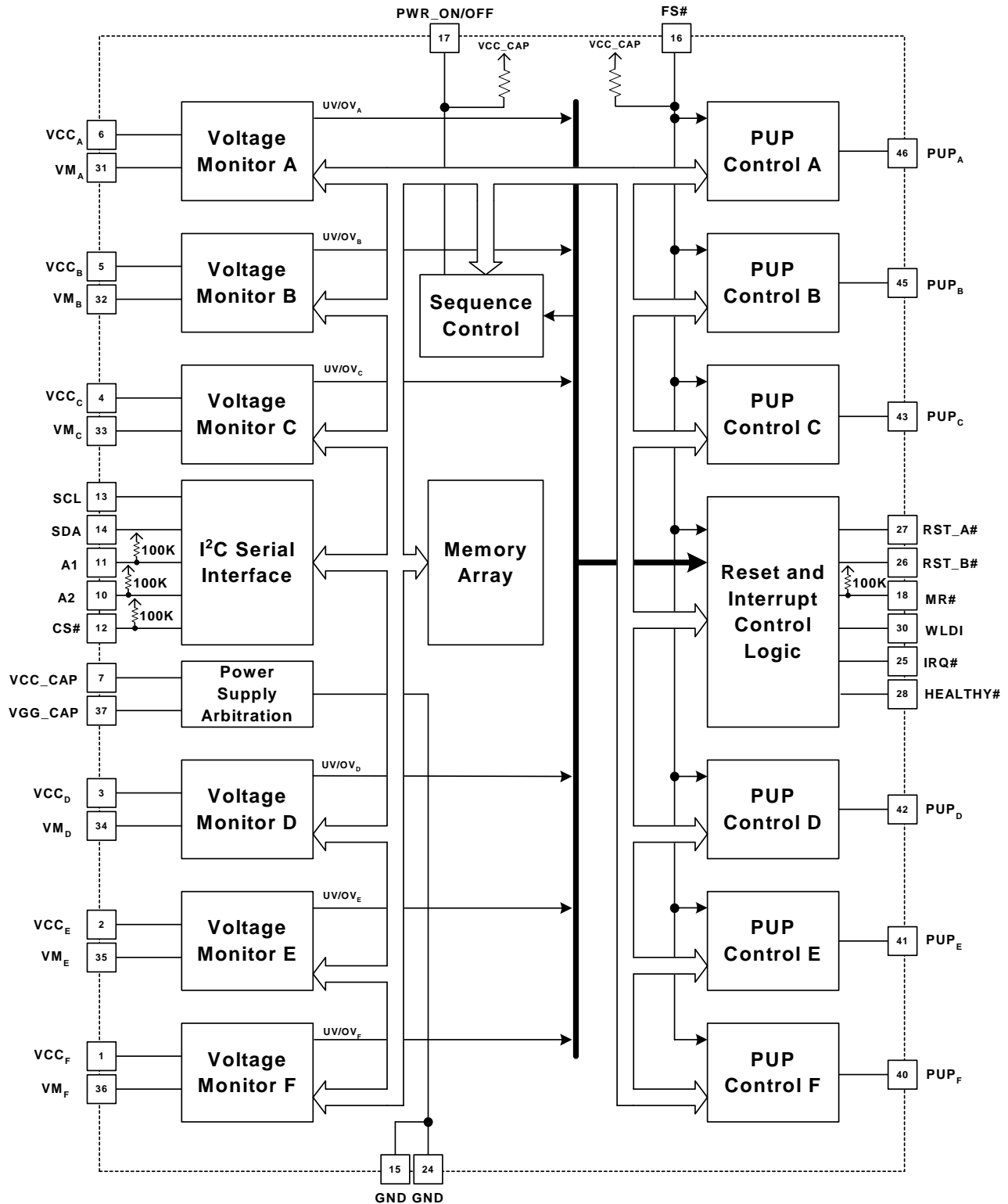



**PIN DESCRIPTIONS**

Pin Number	Pin Type	Pin Name	Pin Description
6	PWR	VCC <sub>A</sub>	<p>The VCC inputs have two functions on the SMS64. They are used as the power supply inputs and as such are diode-OR'ed so that at any point in time the highest potential input will be the power source for the SMS64. So long as one of the inputs is at or above 1V the RESET outputs will be active. For proper device operation, including sequencing, at least one of the pins must be at or above 2.7V.</p> <p>Each VCC input can be programmed as a voltage sensing input. It will only be used as a precursor to power-on sequencing. Once it reaches its V<sub>PTH</sub> the comparator's source input will be switched to its corresponding VM input.</p>
5	PWR	VCC <sub>B</sub>	
4	PWR	VCC <sub>C</sub>	
3	PWR	VCC <sub>D</sub>	
2	PWR	VCC <sub>E</sub>	
1	PWR	VCC <sub>F</sub>	
7	PWR	VCC_CAP	VCC_CAP is a charge storage connection to the SMS64's internal power supply. For most applications this pin is tied to a 10µF capacitor.
10	I	A2	<p>The address pins are biased either to VCC_CAP or GND. When communicating with the SMS64 over the 2-wire bus these pins provide a mechanism for assigning a unique bus address. A2 and A1 are internally connected to VCC through a 100KΩ resistor.</p>
11	I	A1	
12	I	CS#	The Chip Select input is used solely for enabling communication on the 2-wire bus. In order to write or read the registers or the memory array the CS# input must be low. CS# is internally connected to VCC through a 100KΩ resistor.
13	I	SCL	The SCL input is used to clock data into and out of the memory array. In the write mode, data must remain stable while SCL is HIGH. In the read mode, data is clocked out on the falling edge of SCL.
14	I/O	SDA	SDA is the bidirectional serial data pin. It is configured as an open drain output and will require a pull-up resistor to VCC_CAP or a higher potential system supply.
15	PWR	GND	GND is the ground for both the analog and digital portions of the internal circuitry. It is internally tied to pin 24. (Both pins should be tied to system ground).
16	I	FS#	The force shutdown input is used to immediately turn off all PUP outputs. FS# is internally connected to VCC through a 100KΩ resistor.
17	I	PWR_ON/OFF	<p>The PWR_ON/OFF input is used to initiate power-on and power-off sequencing. When the input is high and all of the programmed preconditions are met, the SMS64 will power-on.</p> <p>If the input is taken low, the SMS64 will begin the power-off operation. If programmed to do so, the SMS64 will sequence off the PUP outputs either in the power-on order or reverse order. PWR_ON/OFF is internally connected to VDD through a 100KΩ resistor.</p>
18	I	MR#	<p>MR# is the manual reset input. When MR# is taken low the RST_A# and RST_B# outputs will be driven low. The RST outputs will stay low so long as the MR# input is low, and will remain low for t<sub>PRT0</sub> after MR# returns high (so long as no other reset conditions exist).</p> <p>MR# must be low in order to write to the configuration registers and high to write to the memory array (see descriptions on page 16). MR# is internally connected to VCC through a 100kΩ pull-up resistor.</p>



**PIN DESCRIPTIONS CONT'D**

Pin Number	Pin Type	Pin Name	Pin Description
24	PWR	GND	GND is the ground for both the analog and digital portions of the internal circuitry. It is internally tied to pin 15. (Both pins should be tied to system ground).
25	O	IRQ#	The interrupt output is an active low open-drain output. It will be driven low whenever the Watchdog timer times out or whenever an enabled under-voltage or over-voltage condition on a VM input exists. <b><i>The IRQ# signal is held in an inactive state during the power-on and power-off sequence.</i></b>
26	O	RST_B#	During the power-on sequence RST_B# will be asserted (driven low) until the entire power-on sequence has been completed and the programmable reset interval timer (t <sub>PRTO</sub> ) has elapsed. RST_B# will be forced low by asserting the MR# input. It will remain low so long as the MR# input is low plus the programmed reset time out period for RST_B#. RST_B# will be asserted whenever an enabled UV/OV condition exists. RST_B# will remain active so long as the UV/OV condition exists and t <sub>PRTO</sub> expires. The RST_B# is an active low open drain output.
27	O	RST_A#	During the power-on sequence RST_A# will be driven low and will remain low until a selected PUP output has become active, and the triggers for RST_A# are inactive. In this manner the RST_A# can be used to release a portion of the circuitry from reset before the entire system is energized. RST_A# will be forced low by asserting the MR# input. It will remain low so long as the MR# input is low plus the programmed reset time out period for RST_A#. RST_A# will be asserted whenever an enabled UV/OV condition exists. RST_A# will remain active so long as the UV/OV condition exists and t <sub>PRTO</sub> expires. The RST_A# is an active low open drain output.
28	O	HEALTHY#	The healthy output is used to signal that the VM inputs are not generating any under-voltage or over-voltage conditions.
30	I	WLDI	WLDI is the Watchdog and Longdog timers' interrupt input. A low to high transition on the WLDI input will clear both the Watchdog and Longdog timers, effectively starting a new time-out period. If WLDI is stuck low and no low-to-high transition is received within the programmed t <sub>PWDTO</sub> period (programmed watch dog time-out) IRQ# will be driven low. If a transition is still not received within the programmed t <sub>PLDTO</sub> period (programmed Longdog time-out) RESET# will be driven low. Refer to Figure 5 for a detailed illustration. Holding WLDI high will block interrupts from occurring but will not block the Longdog from timing out and generating a reset. Refer to Figure 3 for a detailed illustration of the relationship between IRQ#, RESET#, and WLDI.
31	I	VM <sub>A</sub>	The VM pins are the voltage monitor inputs. The input voltage is either compared to a programmed threshold voltage (V <sub>PTH</sub> ) or it can be compared to a preset reference voltage of 0.5V.
32	I	VM <sub>B</sub>	
33	I	VM <sub>C</sub>	
34	I	VM <sub>D</sub>	
35	I	VM <sub>E</sub>	
36	I	VM <sub>F</sub>	



**PIN DESCRIPTIONS CONT'D**

Pin Number	Pin Type	Pin Name	Description
37	PWR	VGG_CAP	VGG_CAP is a charge storage connection for the internal charge pump of the SMS64. This capacitor should be of sufficient size so as to provide current, under varying load conditions, to the PUP outputs that are programmed as high side drivers. For most applications this can be tied to a 01 $\mu$ F capacitor.
40	O	PUP <sub>F</sub>	<p>The points of use power enable (PUP) outputs are used when cascading or sequencing external supplies such as LDO's DC-to-DC converters or MOSFETs.</p> <p>The output can be configured as an open drain active high or active low output. In both configurations an external pull-up resistor is required.</p> <p>The output can also be configured as a high-side driver output. The output voltage for this configuration can be set at 10.5V or 14.5V.</p>
41	O	PUP <sub>E</sub>	
42	O	PUP <sub>D</sub>	
43	O	PUP <sub>C</sub>	
45	O	PUP <sub>B</sub>	
46	O	PUP <sub>A</sub>	

**PACKAGE & PIN CONFIGURATION**

48 PIN TQFP

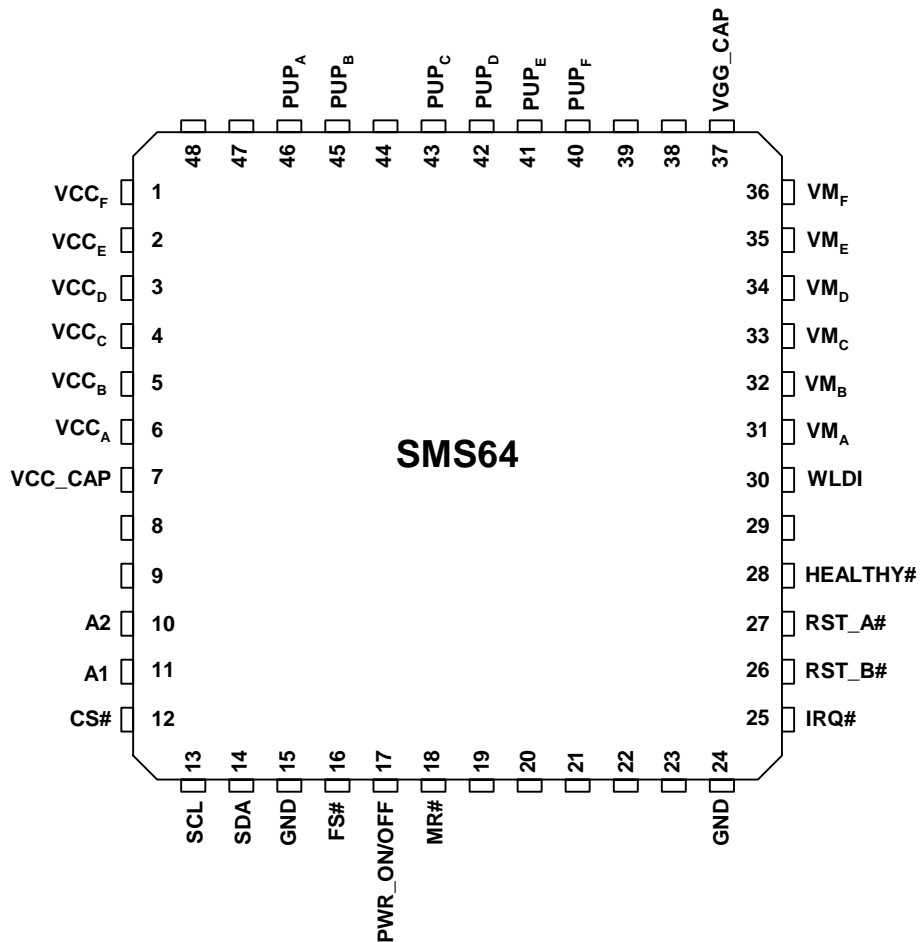



**ABSOLUTE MAXIMUM RATINGS**

Temperature Under Bias ..... -55°C to 125°C  
 Storage Temperature..... -65°C to 150°C  
 Terminal Voltage with Respect to GND:  
 VCC<sub>A</sub>, VCC<sub>B</sub>, VCC<sub>C</sub>, VCC<sub>D</sub>, VCC<sub>E</sub>, VCC<sub>F</sub>..-0.3V to 6.0V  
 VM<sub>A</sub>, VM<sub>B</sub>, VM<sub>C</sub>, VM<sub>D</sub>, VM<sub>E</sub>, VM<sub>F</sub>.....-0.3V to 6.0V  
 PUP<sub>A</sub>, PUP<sub>B</sub>, PUP<sub>C</sub>, PUP<sub>D</sub>, PUP<sub>E</sub>, PUP<sub>F</sub> ..... 15.5V  
 All Others .....V<sub>CC</sub> + 0.7V  
 Output Short Circuit Current ..... 100mA  
 Lead Solder Temperature (10 secs)..... 300°C  
 ESD Rating per JEDEC.....2000V  
 Latch-Up testing per JEDEC.....+/- 100mA

**RECOMMENDED OPERATING CONDITIONS**

Temperature Range(Ambient).....-40° C to +85°C  
 Supply Voltage.....2.7V to 6.0V <sup>1/</sup>  
 Package Thermal Resistance (θ JA)  
 48 Lead SSOP.....80°C/W  
 Moisture Classification Level 1 (MSL 1) per J-STD- 020

**RELIABILITY CHARACTERISTICS**

Data Retention.....100 Years  
 Endurance.....100,000 Cycles

Stresses listed under Absolute Maximum Ratings may cause permanent damage to the device. These are stress ratings only and functional operation of the device at these or any other conditions outside those listed in the operational sections of the specification is not implied. Exposure to any absolute maximum rating for extended periods may affect device performance and reliability. Devices are ESD sensitive. Handling precautions are recommended.

**DC OPERATING CHARACTERISTICS**

(Over recommended operating conditions, unless otherwise noted. All voltages are relative to GND.)

Symbol	Parameter	Notes	Min.	Typ.	Max	Unit
VCC	Supply Voltage VCC <sub>A</sub> , VCC <sub>B</sub> , VCC <sub>C</sub> , VCC <sub>D</sub> , VCC <sub>E</sub> , VCC <sub>F</sub>	Device supply voltage defined by the highest of the six VCC inputs. Must be ≥ 2.7V. – Note 1/	2.7		6.0	V
I <sub>DD</sub> (ON)	Power Supply Current	Active Current with PUP Outputs configured as high-side drivers enabled			2	mA
I <sub>DD</sub> (Off)		Quiescent Current high-side PUP Outputs disabled			1	mA
P <sub>VIT</sub>	Programmable Threshold (VCC and VM Inputs)	8-bit resolution 20mV/bit	0.9		6.0	V
V <sub>TH</sub>	Fixed threshold Voltage	“naked” mode, V input disconnected from ground		0.5		V
<b>PUP characteristics when configured as high-side driver</b>						
P <sub>VPUP</sub>	Programmable PUP Output	Option 1 (MOSFETs on)		14.5		V
		Option 2 (MOSFETs on)		10.5		V
V <sub>PUP OFF</sub>	PUP Output	I <sub>PUPSINK</sub> = 2mA	0		0.4	V
I <sub>PUP</sub>	PUP Drive Current	When configured as high-side driver and with MOSFET switches on			8	μA
SR <sub>PUP</sub>	PUP Slew Rate	When Configured as High Side Driver		250		V/s
<b>PUP characteristics when configured as a logic output</b>						
V <sub>OL</sub>	Output Low Voltage	I <sub>SINK</sub> = 2mA	0		0.4	V
<b>All other input and output characteristics</b>						
V <sub>IH</sub>	Input High Voltage (FS#, PWR_ON/OFF, MR#)	VCC = 2.7V	0.9xVI		VI	V
		VCC = 5.0V	0.7xVI		VI	V
V <sub>IL</sub>	Input Low Voltage (FS#, PWR_ON/OFF, MR#)	VCC = 2.7V	-0.1		0.1xVI	V
		VCC = 5.0V	-0.1		0.3xVI	V
V <sub>OL</sub>	Open Drain Outputs (RST_A#, RST_B#, IRQ#, HEALTHY#)	I <sub>SINK</sub> = 2mA	0		0.4	V

Notes: 1/ At least one of the VCC inputs needs to be at or above 2.7V for proper device operation.



**PROGRAMMABLE AC SPECIFICATIONS** NOTE 1

(Over recommended operating conditions, unless otherwise noted. All voltages are relative to GND.)

Symbol	Description	Min.	Typ.	Max.	Unit
t <sub>DPON</sub>	Programmable delay from VM P <sub>VIT</sub> to PUP power-on (Fast)		1.56		ms
			3.125		ms
			6.25		ms
			12.5		ms
	Programmable delay from VM P <sub>VIT</sub> to PUP power-on (Slow)		25		ms
			50		ms
			100		ms
			200		ms
t <sub>DPOFF</sub>	Programmable delay from VM P <sub>VIT</sub> to PUP power-off (Fast)		1.56		ms
			3.125		ms
			6.25		ms
			12.5		ms
	Programmable delay from VM P <sub>VIT</sub> to PUP power-off (Slow)		25		ms
			50		ms
			100		ms
			200		ms
t <sub>WDTO</sub>	Programmable Watchdog Timer Time-out Periods		Off		
			0.4		s
			0.8		s
			1.6		s
			3.2		s
			6.4		s
t <sub>LDTO</sub>	Programmable Longdog Timer Time-out Periods		Off		
			1.6		s
			3.2		s
			6.4		s
t <sub>PRTO</sub>	Programmable Reset Time-out Periods		25		ms
			50		ms
			100		ms
			200		ms

Notes: 1/ Refer to the timing diagrams in Figures 5, 9 and 10.



## DEVELOPMENT HARDWARE & SOFTWARE

The end user can obtain the Summit SMX3200 programming system for device prototype development. The SMX3200 system consists of a programming Dongle, cable and Windows GUI software. It can be ordered on the website or from a local representative. The latest revisions of all software and an application brief describing the SMX3200 is available from the website ([www.summitmicro.com](http://www.summitmicro.com)).

The SMX3200 programming Dongle/cable interfaces directly between a PC's parallel port and the target application. The device is then configured on-screen via an intuitive graphical user interface employing drop-down menus.

The Windows GUI software will generate the data and send it in I<sup>2</sup>C serial bus format so that it can be directly downloaded to the SMS64 via the programming Dongle and cable. An example of the connection interface is shown in Figure 2.

When design prototyping is complete, the software can generate a HEX data file that should be transmitted to Summit for approval. Summit will then assign a unique customer ID to the HEX code and program production devices before the final electrical test operations. This will ensure proper device operation in the end application.

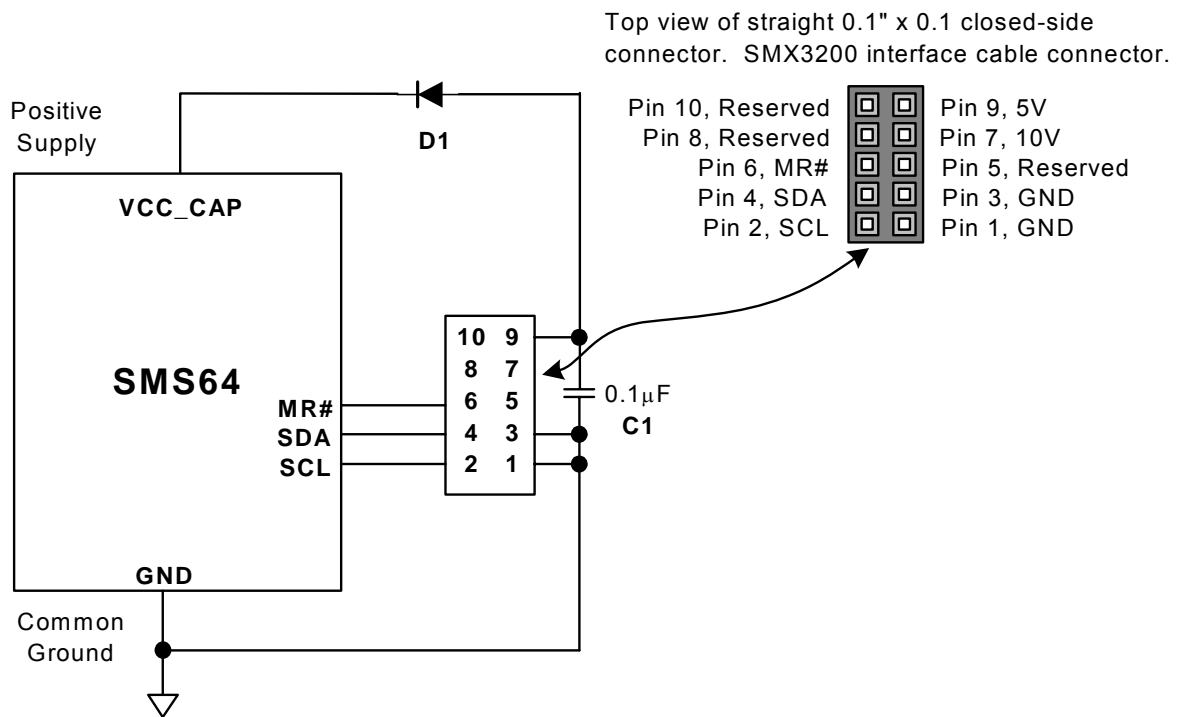

**Figure 2 – SMX3200 Programmer I<sup>2</sup>C serial bus connections to program the SMS64.** Normally SDA and SCL signals require on board pull-up resistors, however, both the SMS64 and the SMX3200 have internal pull-up resistors. D1 is needed between the Dongle Supply and Vcc\_Cap so that there will be no contention between the two supplies. C1 is for noise bypassing.



**APPLICATIONS INFORMATION**

**VOLTAGE MONITOR**

Figure 3 shows a block diagram of a voltage monitor. The curved resistive element is a symbolic representation of a non-volatile DAC. When using the SMX3200 (dongle) and GUI software the threshold level that is selected is programmed into the SMS64, effectively adjusting the output of the DAC to the requested threshold detection level. The internal detection circuit resolution is 8-bits and the threshold detection range is 0.9V to 6.0V. This allows adjusting the programmable threshold voltage ( $V_{PTH}$ ) in 20mV increments.

In applications where the voltage to be monitored is outside the standard range, or is even a negative voltage, the 'naked input' option can be selected. This will effectively disconnect the DAC from ground making the VCC and VM high impedance inputs to the DAC. With this option selected the input is directly compared to the internal reference voltage of 0.5V. This will require the use of an external resistor divider circuit. If this option is selected, the user must insure that the external resistors will not allow the VCC or VM inputs to exceed the recommended operating ranges.

The comparator has two mux'ed voltage inputs, VCC and VM. The VCC inputs are used as 'precondition qualifiers' (No fault conditions exist) before the SMS64 is ready to begin any power-on sequence. Once the sequence has commenced the mux will automatically switch the comparator to the VM input. {When using the GUI for the SMS64 this option is on the channel settings tab and located in the block designated 'triggers'}

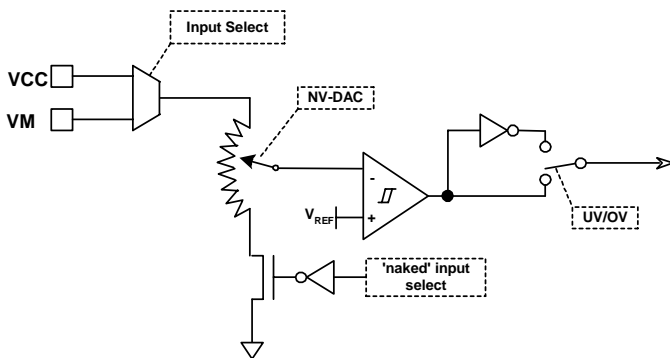

Figure 3. Voltage Monitor Diagram

The VCC inputs are also used as the supply input for the SMS64. Internally all of the VCC inputs are diode-OR'ed and the highest VCC input will effectively become the SMS64 VDD supply. If the VCC input is not selected as a precursor to power-on, it can be tied to the corresponding VM input, left open or be tied to one of the other VCC inputs

The output of the comparator is programmable to generate either an over-voltage or under-voltage signal.

**PUP OUTPUTS**

The primary function of the PUP outputs is to turn-on or switch external power sources; for example, turning on low drop-out regulators or DC-to-DC converters or by providing a high-side drive output to a MOSFET (Figure 4)

Each PUP output can be programmed as active high or active low. If active low, the SMS64 will pull the PUP output to GND in its active state. An external pull-up resistor must be tied to the PUP output.

If active high is selected, an inactive PUP output will be pulled low. Asserting the PUP output will release the open drain output, necessitating an external pull-up resistor. When the PUP outputs are configured as active high or active low they must not be pulled-up to a potential higher than VDD\_CAP.

The PUP output can also be configured as a high-side driver that can be used to turn on the gate of an external MOSFET. The gate voltage for all PUP outputs can be programmed to either 10.5V or 14.5V.

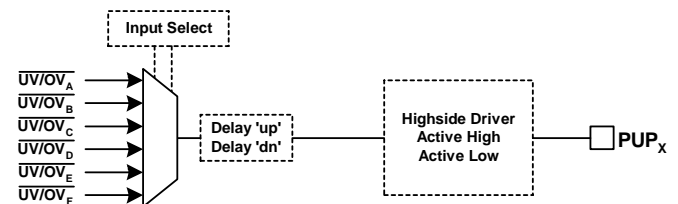

Figure 4. PUP Configuration Diagram

**APPLICATIONS INFORMATION (CONTINUED)****POWER SEQUENCING**

The SMS64 is a programmable controller for power supply sequencing. Up to six channels can be sequenced in any order with several delay options.

In order for a power supply to be sequenced it must be enabled by a PUP output and monitored by the corresponding VM input. This channel must also be programmed to participate in the sequence and be assigned to a sequence position. If a channel is not programmed to participate in the sequence it should be assigned to the null sequence position (position 7) and the channel will act strictly as a voltage monitor. A sequence position is given to each channel as an order to the sequence. The sequence position assignments must begin at position 0 and must not skip positions. Also, multiple channels can be programmed into the same sequence position to enable more than one supply at a time. Note: If two or more channels with high voltage PUP outputs share the same sequence position their power-on delays must be either equal or differ by at least  $t_{SLEW}$  (time it takes for the PUP output to slew from 0V to the level of VGG\_CAP).

Each channel selected for sequencing is given a power-on and power-off delay. The power-on delay is a delay from the VM input of one channel going out of fault to the PUP output of another channel going active. The power-off delay is the delay from the VM input of one channel turning off to the PUP output of another channel that is turning off. The power-on and power-off delay options are 25ms, 50ms, 100ms and 200ms. If the fast times option is selected in the configuration register, these delays are divided by 16 (1.5625ms, 3.125ms, 6.25ms and 12.5ms).

Before the SMS64 begins the power-on sequencing the voltage monitors are monitoring the VCC inputs. The power-on sequencing will not begin until all of the VCC inputs that are selected as precursors to power-on sequencing are out of their fault conditions, the 'precondition qualifiers'.

Power-on sequencing can be initiated by toggling the PWR\_ON/OFF pin from low to high or by writing to the power-on bit of the command register. For automatic start-up the PWR\_ON/OFF can be floated as the device receives power. Either of these will initiate the power-on sequence as soon as the precursor conditions are met. During the power-on sequence power-off commands as well as activity on the PWR\_ON/OFF pin is ignored.

The power-on sequencing begins with the power-on delay time of the channel(s) in sequence position 0. Once this delay has timed out the PUP will go active. At this point the supply connected to the VM input will begin to turn on. When this supply reaches its programmed threshold (under-voltage) and the PUP output has reached the level of VGG\_CAP (high voltage PUP outputs only) the sequence position counter will change to position 1 and the power-on delay timer for the channel(s) in sequence position 1 will begin. This will repeat until all channels that were programmed for sequencing have turned on and are not in fault conditions. Once sequencing is complete RST\_B# will clear after  $t_{PRTO}$ .

Power-off sequencing can be initiated by a high to low transition on the PWR\_ON/OFF pin, by writing to the power-off bit of the command register, or triggered off of a selected fault condition. The SMS64 can be configured to sequence the supplies off in the same order or reverse order of the power-on sequence. During the power-off sequence power-on commands as well as activity on the PWR\_ON/OFF pin is ignored.

The power-off sequencing begins with the power-off delay time of the channel(s) in the last sequence position of the power-on sequence (reverse order). Once this delay has timed out the PUP will turn off. At this point the supply connected to the VM input will begin to turn off. When this supply falls below 0.8V the sequence position counter will change to the next position and the power-off delay timer for the channel(s) in current sequence position will begin. This will repeat until all channels that were programmed for sequencing have turned off. At this point the voltage monitors will switch from the VM inputs to the VCC inputs to monitor for the precursor conditions to power-on sequencing. Note: With the OFF sensors disabled (configuration option) the SMS64 will immediately increment to the next sequence position instead of waiting until the VM inputs reach 0.8V.

**FORCED SHUTDOWN**

The forced shutdown function is always enabled. This function is used to immediately turn off all PUP outputs when there is not enough time to perform a power-off sequence. Forced shutdown can be initiated by pulling the FS# pin low, by writing to the forced shutdown bit of the command register, or triggered off of a selected fault condition.

**APPLICATIONS INFORMATION (CONTINUED)**

The SMS64 can be configured to latch a forced shutdown until either power is recycled to the device or until all the VM inputs of the channels used in sequencing have fallen below 0.8V. Note: With the latter configuration and with the OFF sensors disabled, the SMS64 will not latch a force shutdown command.

**RST\_A# OUTPUT**

RST\_A# has eight sources for activation (see Figure 5). Any one of the voltage monitor UV/OV outputs can be programmed as a source. If a selected UV/OV condition occurs, the RST\_A# output will be driven low and remain low so long as the fault condition is present. If the fault condition is cleared, RST\_A# will remain low for  $t_{PRT0}$  (programmed reset timeout period) and then return high.

If the MR# input is taken low, RST\_A# will be asserted. RST\_A# will remain active so long as MR# is low, and will continue driving the RST\_A# output for  $t_{PRT0}$  after MR# returns high. The affect of the MR# input on RSTA# cannot be bypassed or disabled.

If the Longdog timer is enabled, RST\_A# will be driven low and remain low for  $t_{PRT0}$  after a Longdog time out period.

During power-on sequencing RST\_A# can be cleared by a selected PUP output going active, provided there are no other RST\_A# triggers active and that RST\_A# has been triggered prior to this event.. This allows RST\_A# to be cleared prior to RST\_B#: thereby, providing a mechanism to bring one portion of circuitry out of reset before another.

**RST\_B# OUTPUT**

RST\_B# has eight sources for activation (see Figure 5). Any one of the voltage monitor UV/OV outputs can be programmed as a source. If a selected UV/OV condition occurs, the RST\_B# output will be driven low and remain low so long as the fault condition is present. If the fault condition is cleared, RST\_B# will remain low for  $t_{PRT0}$  and then return high.

If the MR# input is taken low, RST\_B# will be asserted. RST\_B# will remain active so long as MR# is low, and will continue driving the RST\_B# output for  $t_{PRT0}$  after MR# returns high. The affect of the MR# input on RSTB# cannot be bypassed or disabled.

If the Longdog timer is enabled, RST\_B# will be driven low and remain low for  $t_{PRT0}$  after a Longdog time out period.

**IRQ# OUTPUT**

The IRQ# circuitry is disabled during power-on sequencing until all reset have cleared and the reset interval ( $t_{PRT0}$ ) has timed out. This allows the application circuit to become fully operational before an interrupt can occur. Interrupts are also disabled during power-off sequencing and whenever the FS# input is asserted.

IRQ# has seven sources of activation (see Figure 5). Any one of the voltage monitor UV/OV outputs can be programmed as a source. If a selected UV/OV condition occurs, the IRQ# output will be driven low and remain low so long as the fault condition is present.

The IRQ# output will be asserted if the Watchdog timer times out. The Watchdog timer can be bypassed by programming it off.

After the UV/OV condition has cleared or after the Watchdog timer times out, the IRQ# output can be cleared by two events. If either RST\_A# or RST\_B# times out and returns high, the IRQ# output will be cleared. The IRQ# output will also be cleared by a low to high transition on the WLDI input. IRQ# can be cleared under software control by writing 10<sub>[HEX]</sub> to the command register.

**HEALTHY# OUTPUT**

The HEALTHY# output reflects the state of all of the VM inputs (see Figure 5). The HEALTHY# output will be driven low if there are no fault conditions present.



APPLICATIONS INFORMATION (CONTINUED)

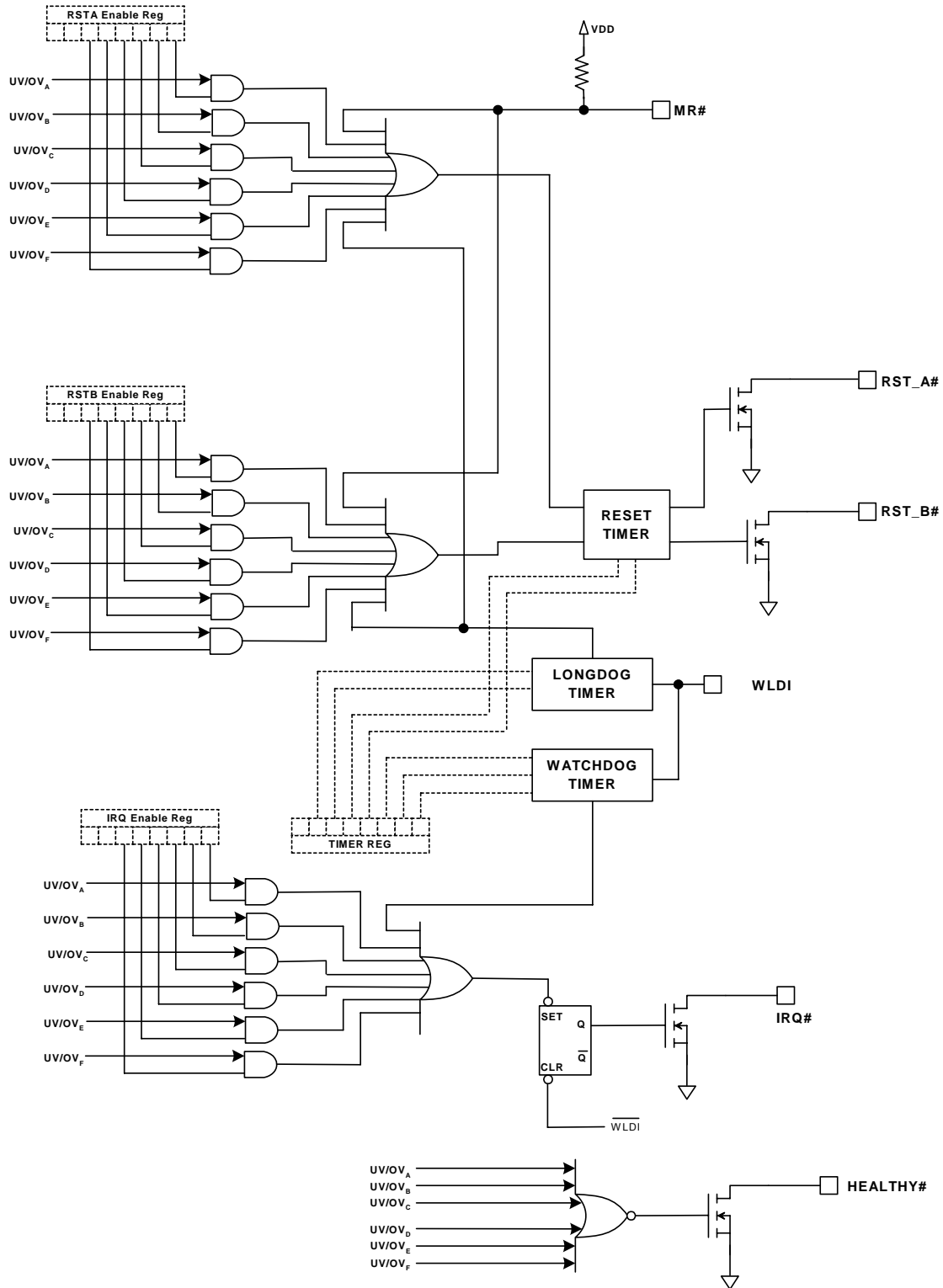

Figure 5. Reset and Interrupt Generation Block Diagram



**APPLICATIONS INFORMATION (CONTINUED)**

**WATCHDOG AND LONGDOG TIMERS**

The SMS64 contains two timers that can be programmed independently. The Watchdog timer will generate an interrupt if it times out. The Longdog timer will generally be programmed to be of longer duration than the Watchdog timer and will generate a reset if it times out. Both timers are cleared by a low to high transition on WLDI and start simultaneously.

If the Longdog times out RST\_A# and RST\_B# will be driven low either until a WLDI clear is received or until t<sub>PRTO</sub> (whichever occurs first), at which time they will return high. When RST\_A# and RST\_B# return high both timers are reset to time zero. Therefore, if the Longdog t<sub>PLDTO</sub> is shorter than the Watchdog t<sub>PWDTO</sub>, RST\_A# and RST\_B# will effectively clear the interrupt before it can drive the output low

If WLDI is held low the timers will free-run generating a series of interrupts and resets. If WLDI is held high the interrupt (Watchdog) output will be disabled and only the reset (Longdog) outputs will be active.

Refer to Figure 6 which illustrates the action of RST\_A#, RST\_B# and IRQ# with respect to the Watchdog and Longdog timers and the WLDI input.

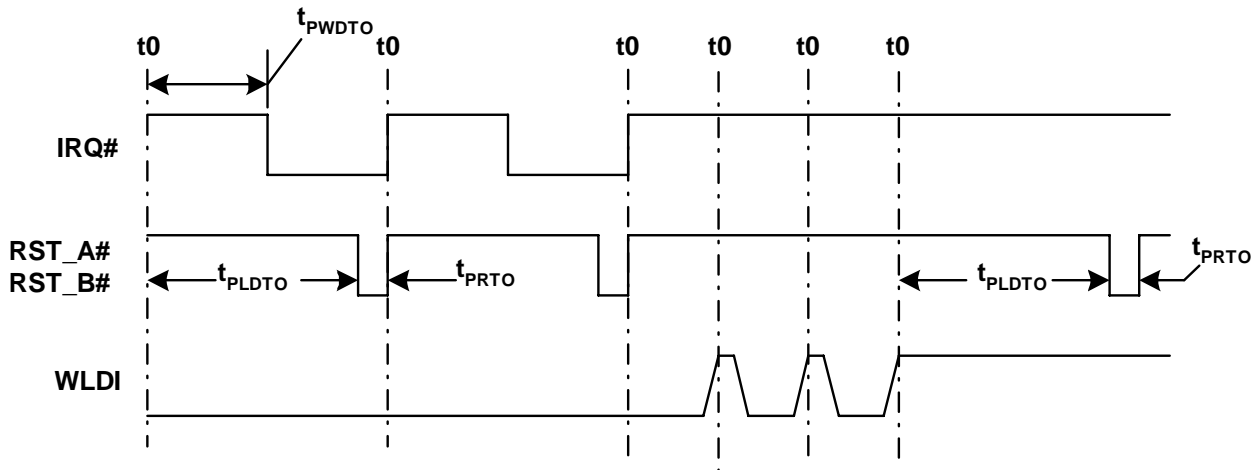

Figure 6. Watchdog, Longdog and WLDI Timing Diagram



APPLICATIONS INFORMATION (CONTINUED)

COMMAND REGISTER

The command register (slave address 1001 [BIN] register address 0F [HEX]) contains 4 bits used for software control of several functions in the SMS64 (see Figure 7). Each of these functions is activated by writing a 1 to the function's bit in the command register (listed below). Only one command can be issued at a time; therefore, only data bytes 80[HEX], 40[HEX], 20[HEX], 10[HEX] and 00[HEX] should be written to the command register. The command register is volatile and will be cleared when power is removed.

Bit 7 is the power-on bit. When active it will initiate a power-on sequence.

Bit 6 is the power-off bit. When active it will initiate a power-off sequence.

Bit 5 is OR'ed with the FS# pin. When active it will turn off all PUP outputs.

Bit 4 is OR'ed with the WLDI pin. When active it will clear both the Longdog and Watchdog timers and block interrupts.

FAULT and STATUS REGISTERS

The fault and status registers (see Figure 7) are volatile registers which reflect the conditions of the VM inputs. In either register a fault condition (under-voltage or over-voltage) is represented as a "1".

The Fault register (located at register address 0D [HEX]) latches the state of the VM inputs when an IRQ# is generated.

The Status register (located at register address 0E [HEX]) reflects the current state of the VM inputs.

CONFIGURATION REGISTERS

The SMS64 has 24 configuration registers that allow programming voltage thresholds, timer values, sequencing order and output configurations. All of these registers are accessible over the I2C serial interface.

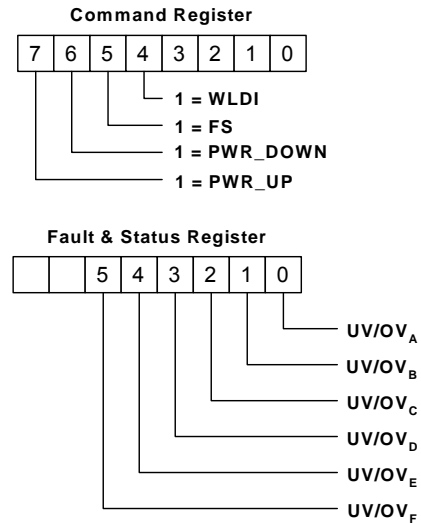

Figure 7 – Command and Status Registers

For prototyping purposes, Summit can provide a programming cable (SMX3200) that interfaces a PC parallel port to the serial interface of the SMS64 (see the 'Development Hardware and Software' section). Summit provides software that can be downloaded from its website without charge. The software provides an intuitive graphical user interface comprised of drop-down menus that make selecting options straightforward, thereby eliminating the need to understand the register configurations in detail.

MEMORY ARRAY

The SMS64 has 4-K bits of nonvolatile memory that is accessible over the 2-wire serial interface. This memory can be used in a dynamic manner by the host processor or it could be used to store board configuration information or board identification information. The slave address used to access the memory can be configured as 1010 [BIN] or 1011 [BIN].

The memory array can be read whenever chip select is enabled (CS# low). In order to prevent inadvertent writes, memory writes are blocked when either RST\_A# or RST\_B# are active. Therefore, the memory can only be written after the device has performed a power-on operation, the reset outputs (RST\_A# and RST\_B#) have timed out and before the device has been issued a force shutdown or power-off command. MR# must also be high.



**APPLICATIONS INFORMATION (CONTINUED)**

**Applications Example**

A simple application example is shown in Figure 8. Three voltages are provided by a motherboard, +5V, +3.3V, and +1.8V. The +5V and +3.3V supplies are switched on through series MOSFETS and applied to the application circuit. The +1.8V supply will drive an LDO, supplying +1.2V to the application circuit. The application requires that the power supplies sequence in the following order: +1.2V, +3.3V, +5.0V. As these supplies are sequenced on, RST\_A# is cleared after the +1.2V supply has reached its under-voltage threshold. RST\_B# is not cleared until the +3.3V and +5.0V supplies have reached their under-voltage threshold. After the supplies have sequenced on, a 10% under-voltage on the +1.2V supply will trigger RSTA#. Similarly, a 10% under-voltage on the +3.3V supply will trigger RSTB#. The devices driven by the application circuit require that if a 10% under-voltage occurs on the +5.0V supply, the SMS64 will generate an IRQ#. A 10% over-voltage on any supply will trigger both RSTA# and RSTB#. This application also requires that the power supplies are sequenced off in the reverse order that they were sequenced on. The power supply sequencing is controlled by toggling the PWR\_ON/OFF pin. With these requirements, the SMS64 is configured as follows:

Channel A  
 Sequenced; Sequence Position 2; Power-On Delay( $t_{DPONA}$ ) = 50ms; Power-Off Delay( $t_{DPOFFA}$ ) = 50ms;  
 Under-voltage; Programmable Threshold( $V_{PTHA}$ ) = 4.50V

Channel B  
 Sequenced; Sequence Position 1; Power-On Delay( $t_{DPONB}$ ) = 25ms; Power-Off Delay( $t_{DPOFFB}$ ) = 25ms;  
 Under-voltage; Programmable Threshold( $V_{PTHB}$ ) = 2.96V

Channel C  
 Sequenced; Sequence Position 0; Power-On Delay( $t_{DPONC}$ ) = 50ms; Power-Off Delay( $t_{DPOFFC}$ ) = 100ms;  
 Under-voltage; Programmable Threshold( $V_{PTHC}$ ) = 1.06V

Channel D  
 Not Sequenced; Sequence Position null (7);  
 Over-voltage; Programmable Threshold( $V_{PTHD}$ ) = 5.50V

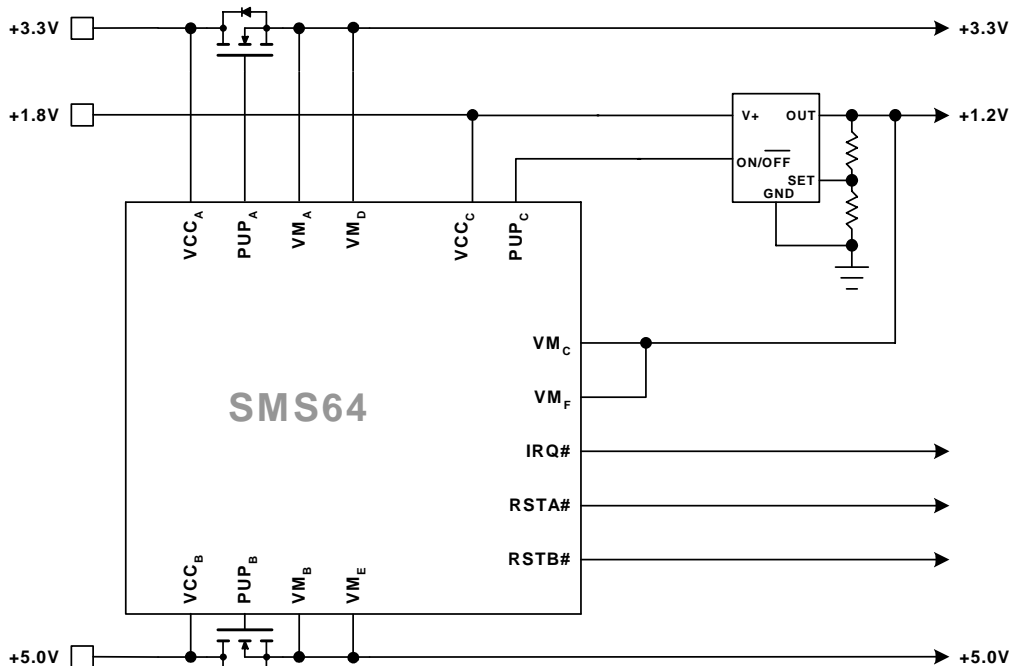

Figure 8 – Simple Applications Example



APPLICATIONS INFORMATION (CONTINUED)

Channel E  
Not Sequenced; Sequence Position null (7);  
Over-voltage; Programmable Threshold( $V_{P_{THE}}$ ) = 3.64V

Channel F  
Not Sequenced; Sequence Position null (7);  
Over-voltage; Programmable Threshold( $V_{P_{THF}}$ ) = 1.34V

Power-Off in reverse order

RST\_A# triggered by channels C, D, E, and F; cleared on PUPB active

RST\_B# triggered by channels B, D, E, and F

IRQ# triggered by channel A

VCCA, VCCB, and VCCC selected as precursors to power-on sequencing

The resulting timing diagram is shown in Figures 9 and 10. Figure 9 shows the SMS64 sequencing the supplies on and then monitoring for fault conditions. Figure 10 shows the SMS64 sequencing the supplies off then sequencing the supplies on.

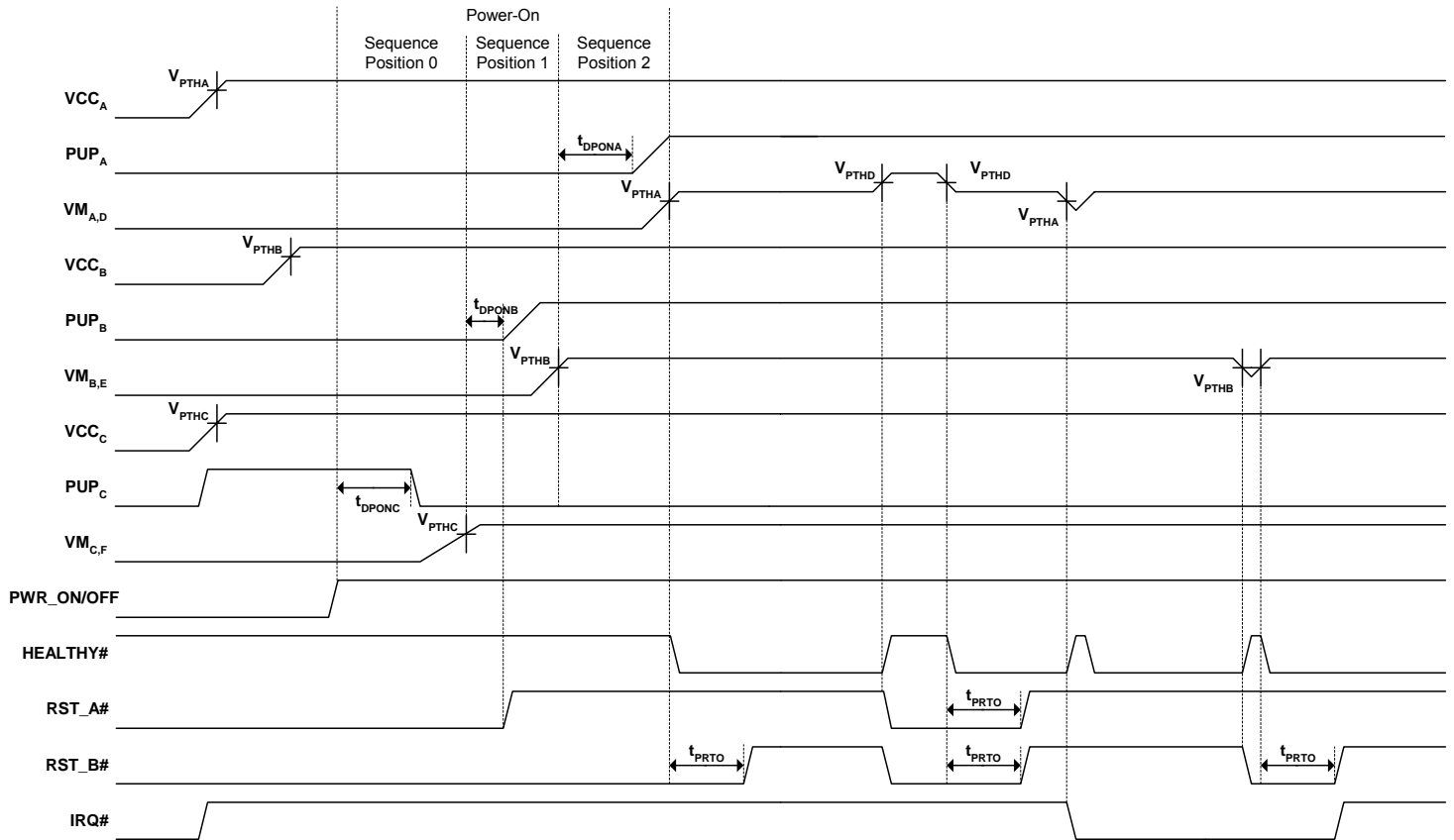

Figure 9 - The SMS64 sequencing the supplies on and then monitoring for fault conditions.



APPLICATIONS INFORMATION (CONTINUED)

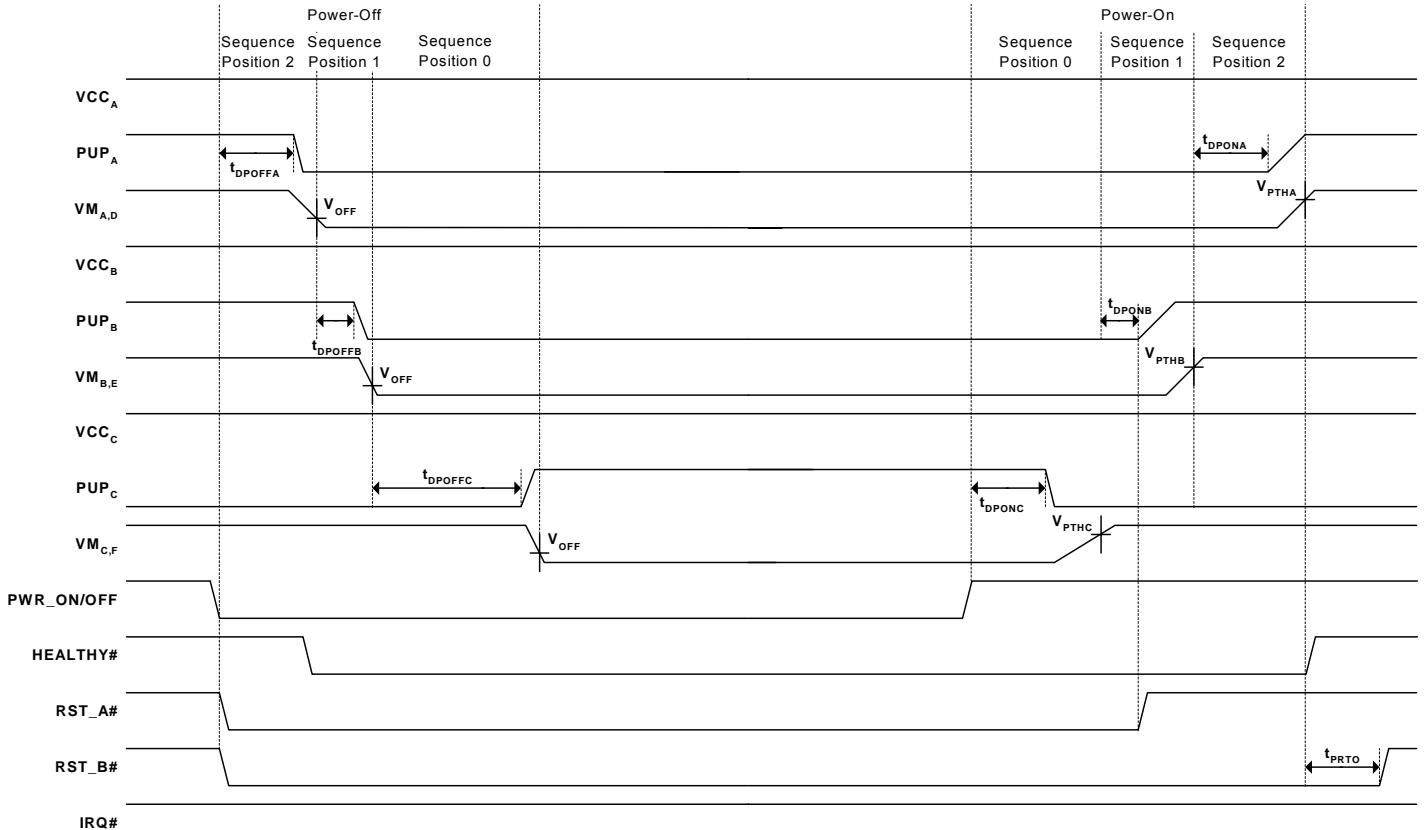

Figure 10 - The SMS64 sequencing the supplies off then sequencing the supplies back on.

Additional Considerations

An example application circuit is shown in Figure 11. Additional optional noise bypassing components are shown for the VMX monitor pins. These components consist of ferrite bead inductors and capacitors. They may be necessary in very noisy systems where tight undervoltage/overvoltage tolerances are needed.

The PUP output pins require series resistors to drive the gates of the power mosfets. Gate capacitors (C27 thru C32) are also recommended to prevent initial mosfet, LDO or dc-dc converter turn-on during the SMS64 power on sequence. To minimize transient power surges in hot-swappable line card designs, place a 0.01µF (10nF), 25V, ceramic capacitor on each PUP output pin to ground.

The PUP output level is programmable to either logic-level, 10.5V or 14V depending on the type of power component used in the system. To minimize the voltage drop across the power mosfets, the device needs to be fully enhanced to minimize  $R_{DS(ON)}$ . However, some mosfets have maximum VGS specifications of 15V while others are 20V. For improved sequencing performance with the SMS64, it is recommended to use the lower rated VGS devices with the PUP outputs set to 10.5V instead of 14V. The industry trend for power mosfets is toward lower VGS specs while also maintaining low  $R_{DS(ON)}$  specifications.



APPLICATIONS INFORMATION (CONTINUED)

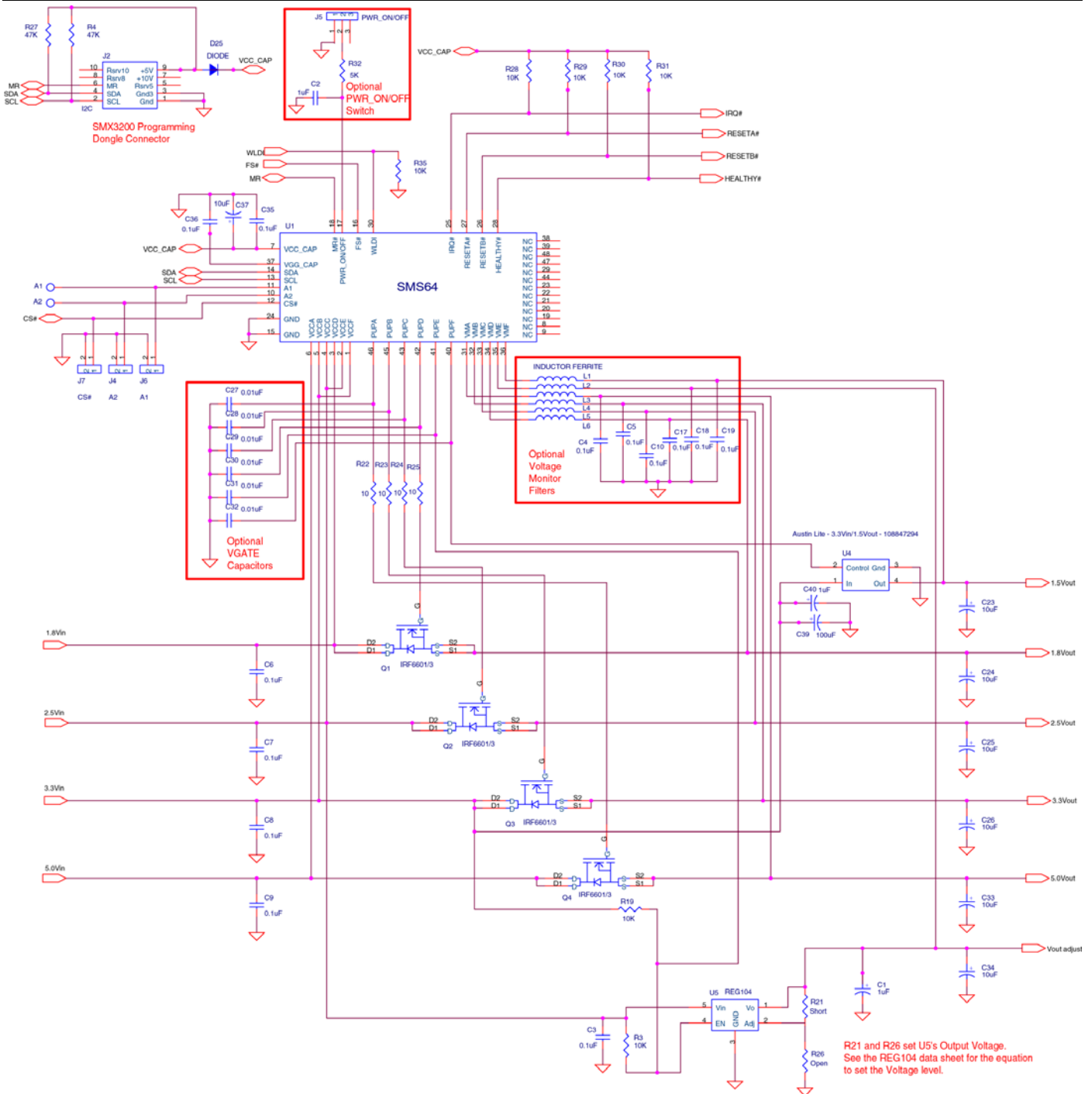

Figure 11 – Example Applications Schematic. In this example, the SMS64 sequences six individual output supply voltages derived from four separate input power supplies by turning on 4 power mosfet switches, one LDO and one dc-dc converter. Six individual input supplies could also be sequenced if needed. The SMS64 can sequence mosfets switches or any other power source with either a negative or positive enable inputs.

**DEFAULT CONFIGURATION REGISTER SETTINGS – SMS64F-116**

Register	Hex Contents	Configured as:
R00	B9	Channel A UV Trip Point = 4.6V
R01	69	Channel B UV Trip Point = 3.0V
R02	37	Channel C UV Trip Point = 2.0V
R03	19	Channel D UV Trip Point = 1.4V
R04	05	Channel E UV Trip Point = 1.0V
R05	05	Channel F UV Trip Point = 1.0V
R06	80	Use Channel A In Sequencing [D7] VCCX To PUPA On Delay = 200ms [D6:5] VCCX To PUPA Off Delay = 200ms [D4:3] PUPA Sequence Position set to 0 [D2:0]
R07	81	Use Channel B In Sequencing [D7] VCCX To PUPB On Delay = 200ms [D6:5] VCCX To PUPB Off Delay = 200ms [D4:3] PUPB Sequence Position set to 1 [D2:0]
R08	82	Use Channel C In Sequencing [D7] VCCX To PUPC On Delay = 200ms [D6:5] VCCX To PUPC Off Delay = 200ms [D4:3] PUPC Sequence Position set to 2 [D2:0]
R09	83	Use Channel D In Sequencing [D7] VCCX To PUPD On Delay = 200ms [D6:5] VCCX To PUPD Off Delay = 200ms [D4:3] PUPD Sequence Position set to 3 [D2:0]
R0A	84	Use Channel E In Sequencing [D7] VCCX To PUPE On Delay = 200ms [D6:5] VCCX To PUPE Off Delay = 200ms [D4:3] PUPE Sequence Position set to 4 [D2:0]
R0B	85	Use Channel F In Sequencing [D7] VCCX To PUPF On Delay = 200ms [D6:5] VCCX To PUPF Off Delay = 200ms [D4:3] PUPF Sequence Position set to 5 [D2:0]
R0C	00	PUP On/Off Use fast times set to OFF [D7] Longdog Timer set to Off [D6:5] RST Timeout Interval set to 25ms [D4:3] Watchdog Timer set to Off [D2:0]

**DEFAULT CONFIGURATION REGISTER SETTINGS – SMS64F-116 (Cont.)**

R10	47	RSTA Trigger on VA Over/UnderVoltage set to RST On VA UV/OV [D0] RSTA on VB Over/UnderVoltage set to RST On VB UV/OV [D1] RSTA on VC Over/UnderVoltage set to RST On VC UV/OV [D2] RSTA on VD Over/UnderVoltage set to No Reset [D3] RSTA on VE Over/UnderVoltage set to No Reset [D4] RSTA on VF Over/UnderVoltage set to No Reset [D5] Memory (EE) Slave Address set to 1010 [D7]
R11	38	RSTB on VA Over/UnderVoltage set to No Reset [D0] RSTB on VB Over/UnderVoltage set to No Reset [D1] RSTB on VC Over/UnderVoltage set to No Reset [D2] RSTB on VD Over/UnderVoltage set to RST On VD UV/OV [D3] RSTB on VE Over/UnderVoltage set to RST On VE UV/OV [D4] RSTB on VF Over/UnderVoltage set to RST On VF UV/OV [D5]
R12	00	IRQ on VA Over/UnderVoltage set to No IRQ [D0] IRQ on VB Over/UnderVoltage set to No IRQ [D1] IRQ on VC Over/UnderVoltage set to No IRQ [D2] IRQ on VD Over/UnderVoltage set to No IRQ [D3] IRQ on VE Over/UnderVoltage set to No IRQ [D4] IRQ on VF Over/UnderVoltage set to No IRQ [D5]
R13	00	PowerOff on VA Over/UnderVoltage set to No PowerOff [D0] PowerOff on VB Over/UnderVoltage set to No PowerOff [D1] PowerOff on VC Over/UnderVoltage set to No PowerOff [D2] PowerOff on VD Over/UnderVoltage set to No PowerOff [D3] PowerOff on VE Over/UnderVoltage set to No PowerOff [D4] PowerOff on VF Over/UnderVoltage set to No PowerOff [D5]
R14	3F	Use Naked Input VA set to No [D0] Use Naked Input VB set to No [D1] Use Naked Input VC set to No [D2] Use Naked Input VD set to No [D3] Use Naked Input VE set to No [D4] Use Naked Input VF set to No [D5]
R15	3F	VA Over/Undervoltage set to Under [D0] VB Over/Undervoltage set to Under [D1] VC Over/Undervoltage set to Under [D2] VD Over/Undervoltage set to Under [D3] VE Over/Undervoltage set to Under [D4] VF Over/Undervoltage set to Under [D5]

**DEFAULT CONFIGURATION REGISTER SETTINGS – SMS64F-116 (Cont.)**

R16	3F	PUPA High/Low Logic Level set to High [D0] PUPB High/Low Logic Level set to High [D1] PUPC High/Low Logic Level set to High [D2] PUPD High/Low Logic Level set to High [D3] PUPE High/Low Logic Level set to High [D4] PUPF High/Low Logic Level set to High [D5]
R17	0F	PUPA High Voltage/Logic Level set to HV [D0] PUPB High Voltage/Logic Level set to HV [D1] PUPC High Voltage/Logic Level set to HV [D2] PUPD High Voltage/Logic Level set to HV [D3] PUPE High Voltage/Logic Level set to not HV [D4] PUPF High Voltage/Logic Level set to not HV [D5]
R18	08	RSTA Cleared on PUPA Active set to No [D0] RSTA Cleared on PUPB Active set to No [D1] RSTA Cleared on PUPC Active set to No [D2] RSTA Cleared on PUPD Active set to Yes [D3] RSTA Cleared on PUPE Active set to No [D4] RSTA Cleared on PUPF Active set to No [D5]
R19	01	Vgate Select set to 14.5V [D0] No ACK For Slave Address 1001 set to ACK [D1] Configuration Lock Option set to Unlocked [D2] Force Shutdown Instead Of Cascade Down set to No [D3] Force Shutdown Latched Until POR set to No [D4] Forward Or Reverse PUP Order set to Reverse [D5] Memory (EE) Slave Address set to 1010 [D7]
R1D	0F	Ready After VCCA OK set to Ready [D0] Ready After VCCB OK set to Ready [D1] Ready After VCCC OK set to Ready [D2] Ready After VCCD OK set to Ready [D3] Ready After VCCE OK set to Not Used [D4] Ready After VCCF OK set to Not Used [D5]

**Application Note 32 contains a complete description of the Windows GUI and the default settings of each of the 24 individual Configuration Registers.**



**PACKAGES**

**48 PIN TQFP PACKAGE**

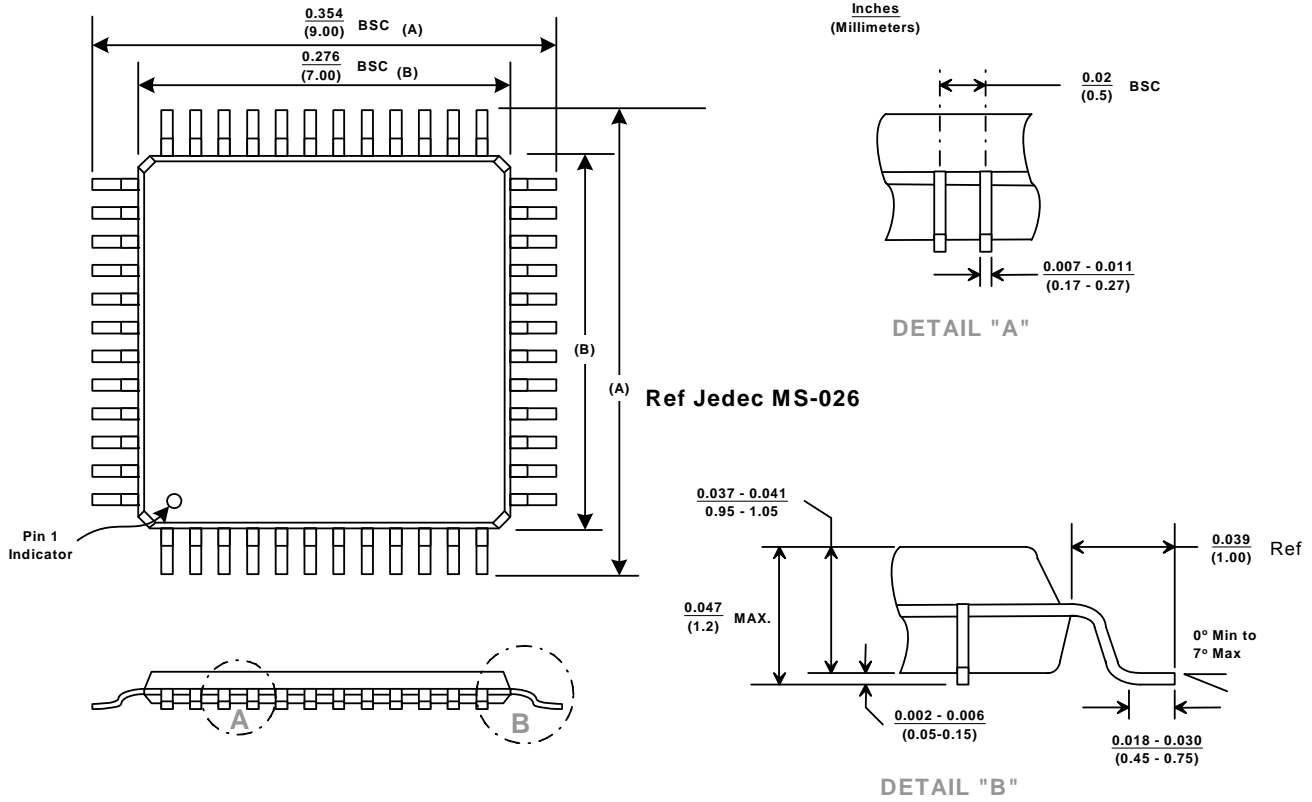



## PART MARKING

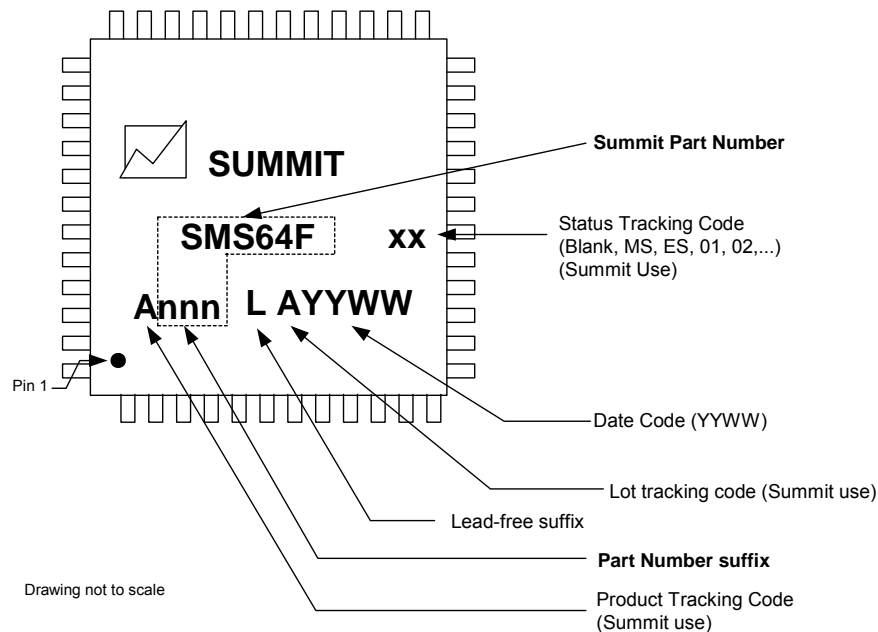

## ORDERING INFORMATION

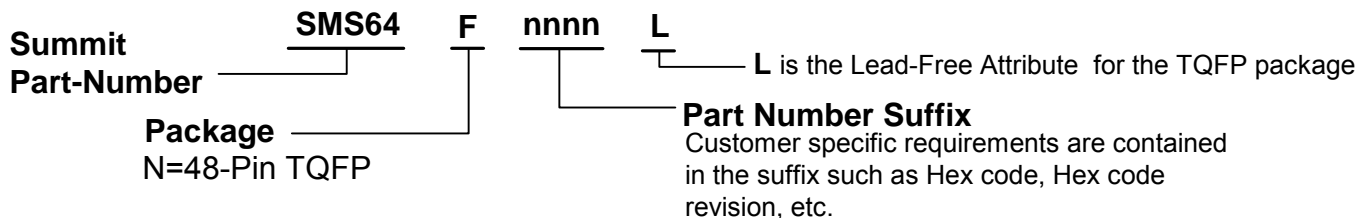

### NOTICE

NOTE 1 - This is a **Preliminary Information** data sheet that describes a Summit product currently in pre-production with limited characterization.

SUMMIT Microelectronics, Inc. reserves the right to make changes to the products contained in this publication in order to improve design, performance or reliability. SUMMIT Microelectronics, Inc. assumes no responsibility for the use of any circuits described herein, conveys no license under any patent or other right, and makes no representation that the circuits are free of patent infringement. Charts and schedules contained herein reflect representative operating parameters, and may vary depending upon a user's specific application. While the information in this publication has been carefully checked, SUMMIT Microelectronics, Inc. shall not be liable for any damages arising as a result of any error or omission.

SUMMIT Microelectronics, Inc. does not recommend the use of any of its products in life support or aviation applications where the failure or malfunction of the product can reasonably be expected to cause any failure of either system or to significantly affect their safety or effectiveness. Products are not authorized for use in such applications unless SUMMIT Microelectronics, Inc. receives written assurances, to its satisfaction, that: (a) the risk of injury or damage has been minimized; (b) the user assumes all such risks; and (c) potential liability of SUMMIT Microelectronics, Inc. is adequately protected under the circumstances.

Revision 2.4 - This document supersedes all previous versions. Please check the Summit Microelectronics Inc. web site at [www.summitmicro.com](http://www.summitmicro.com) for data sheet updates.

© Copyright 2005 SUMMIT MICROELECTRONICS, Inc.

**PROGRAMMABLE POWER FOR A GREEN PLANET™**

I<sup>2</sup>C is a trademark of Philips Corporation.