

**Dual Voltage Supervisory Circuit
 With Watchdog Timer(S42WD61) (S42WD42)**
FEATURES

- Precision Dual Voltage Monitor
 - V_{CC} Supply Monitor
 - Dual reset outputs for complex microcontroller systems
 - Integrated memory write lockout function
 - No external components required
- Second Voltage Monitor Output
 - Separate V_{LOW} output
 - Generates interrupt to MCU
 - Generates RESET for dual supply systems
 - Guaranteed output assertion to $V_{CC} - 1V$
- Watchdog Timer (S42WD42, S42WD61)
 - 1.6s
- Memory Internally Organized 2 x 8
- Extended Programmable Functions Available on SMS24

- High Reliability
 - Endurance: 100,000 erase/write cycles
 - Data retention: 100 years

OVERVIEW

The S42xxx are a precision power supervisory circuit. It automatically monitors the device's V_{CC} level and will generate a reset output on two complementary open drain outputs. In addition to the V_{CC} monitoring, the S42xxx also provides a second voltage comparator input. This input has an independent open drain output that can be wire-OR'ed with the RESET I/O or it can be used as a system interrupt.

The S42xxx also has an integrated 4k/16k-bit nonvolatile memory. The memory conforms to the industry standard two-wire serial interface. In addition to the reset circuitry, the S42WD42/S42WD61 also has a watchdog timer.

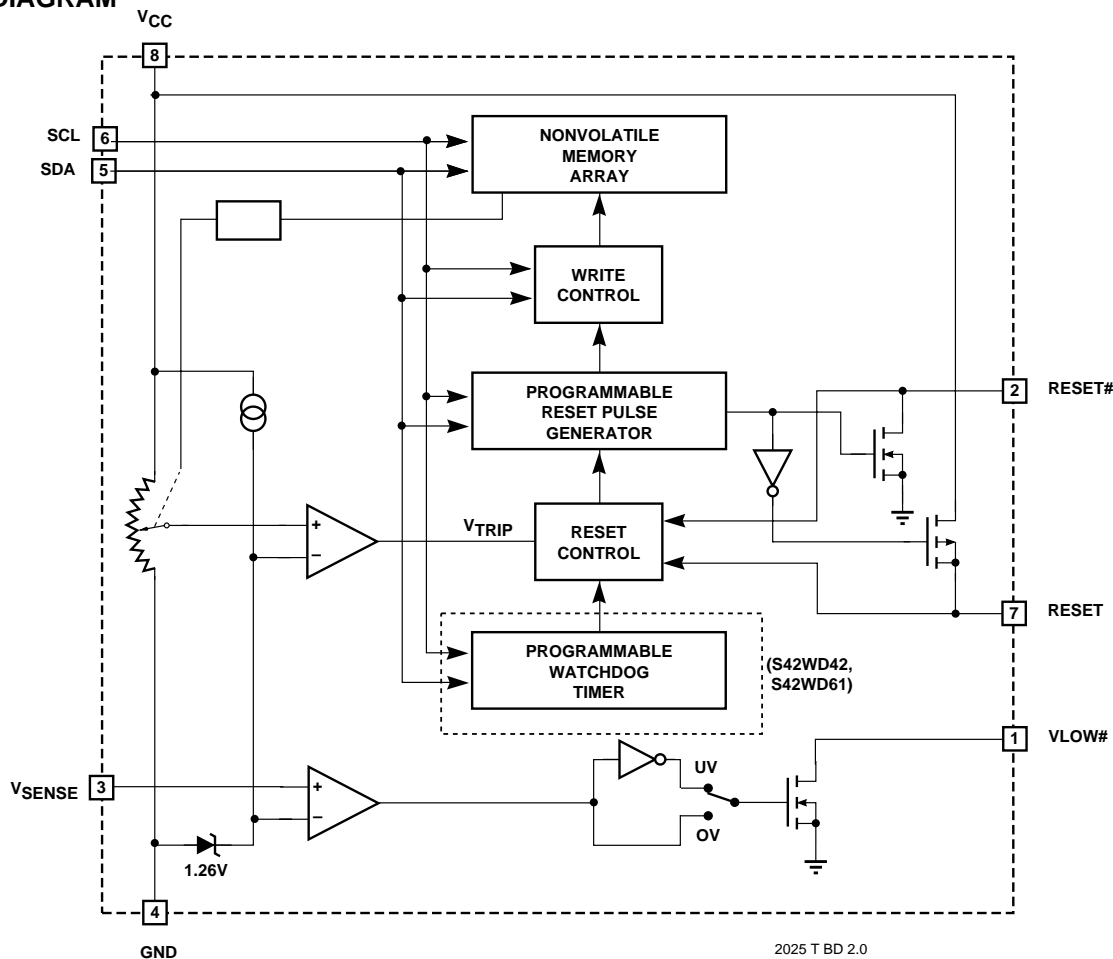
BLOCK DIAGRAM



S4242/S42WD42/S4261/S42WD61

ABSOLUTE MAXIMUM RATINGS

Temperature Under Bias	-40°C to +85°C
Storage Temperature	-65°C to +125°C
Soldering Temperature (less than 10 seconds)	300°C
Supply Voltage	0 to 6.5V
Voltage on Any Pin	-0.3V to $V_{CC}+0.3V$
ESD Voltage (JEDEC method)	2,000V

NOTE: These are STRESS ratings only. Appropriate conditions for operating these devices are given elsewhere in this specification. Stresses beyond those listed here may permanently damage the part. Prolonged exposure to maximum ratings may affect device reliability.

RECOMMENDED OPERATING CONDITIONS

Temperature	Min	Max
Commercial	0°C	+70°C
Industrial	-40°C	+85°C

2025 PGM T1.0

DC ELECTRICAL CHARACTERISTICS (over recommended operating conditions unless otherwise specified)

Symbol	Parameter	Conditions	Min	Max	Units
I _{CC}	Supply Current (CMOS)	SCL = CMOS Levels @ 100KHz SDA = Open All other inputs = GND or V _{CC}	V _{CC} = 5.5V	3	mA
			V _{CC} = 3.3V	2	mA
I _{SB}	Standby Current (CMOS)	SCL = SDA = V _{CC} All other inputs = GND	V _{CC} = 5.5V	50	µA
			V _{CC} = 3.3V	25	µA
I _{LI}	Input Leakage	V _{IN} = 0 To V _{CC}		10	µA
I _{LO}	Output Leakage	V _{OUT} = 0 To V _{CC}		10	µA
V _{IL}	Input Low Voltage	SCL, SDA, RESET# (pin 2)		0.3xV _{CC}	V
V _{IH}	Input High Voltage	SCL, SDA, RESET (pin7)		0.7xV _{CC}	V
V _{OL}	Output Low Voltage	I _{OL} = 3mA SDA		0.4	V

2025 PGM T2.0

AC ELECTRICAL CHARACTERISTICS

(over recommended operating conditions unless otherwise specified)

Symbol	Parameter	Conditions	2.7V to 4.5V		4.5V to 5.5V		Units
			Min	Max	Min	Max	
f _{SCL}	SCL Clock Frequency		0	100		400	KHz
t _{LOW}	Clock Low Period		4.7		1.3		µs
t _{HIGH}	Clock High Period		4.0		0.6		µs
t _{BUF}	Bus Free Time	Before New Transmission	4.7		1.3		µs
t _{SU:STA}	Start Condition Setup Time		4.7		0.6		µs
t _{HD:STA}	Start Condition Hold Time		4.0		0.6		µs
t _{SU:STO}	Stop Condition Setup Time		4.7		0.6		µs
t _{AA}	Clock to Output	SCL Low to SDA Data Out Valid	0.3	3.5	0.2	0.9	µs
t _{DH}	Data Out Hold Time	SCL Low to SDA Data Out Change	0.3		0.2		µs
t _R	SCL and SDA Rise Time			1000		300	ns
t _F	SCL and SDA Fall Time			300		300	ns
t _{SU:DAT}	Data In Setup Time		250		100		ns
t _{HD:DAT}	Data In Hold Time		0		0		ns
T _I	Noise Spike Width @ SCL, SDA Inputs	Noise Suppression Time Constant		100		100	ns
t _{WR}	Write Cycle Time			10		10	ms

2025 PGM T3.0



S4242/S42WD42/S4261/S42WD61

CAPACITANCE

$T_A = 25^\circ\text{C}$, $f = 100\text{KHz}$

Symbol	Parameter	Max	Units
C _{IN}	Input Capacitance	5	pF
C _{OUT}	Output Capacitance	8	pF

2025 PGM T4.0

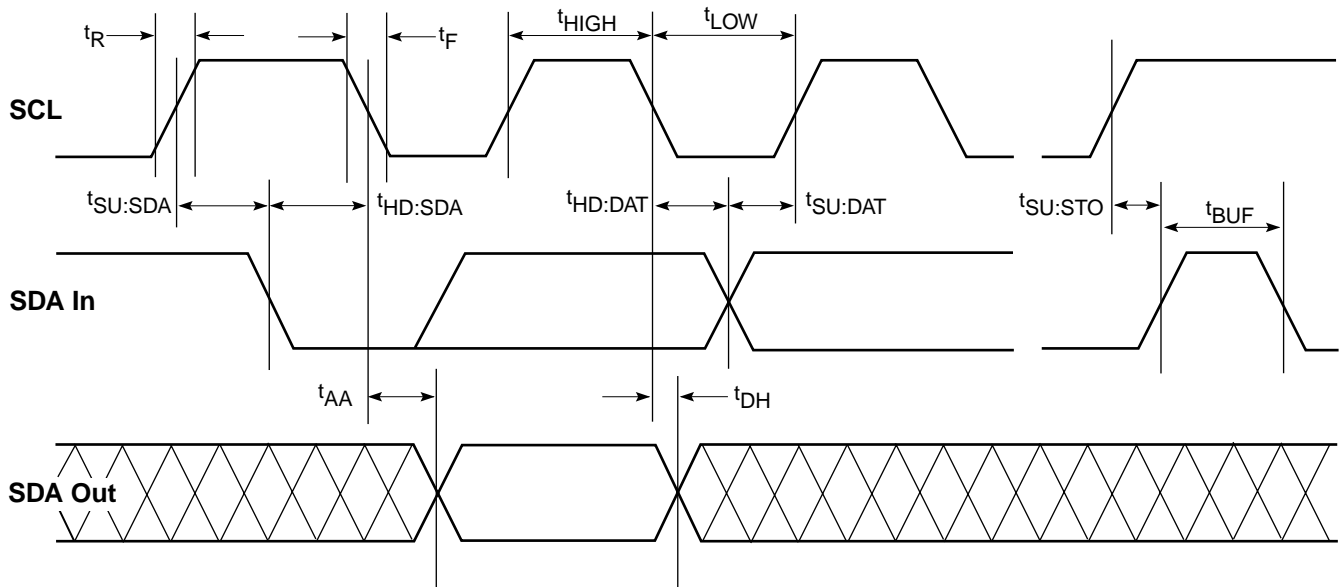

2025 Fig01 1.0

FIGURE 1. BUS TIMING

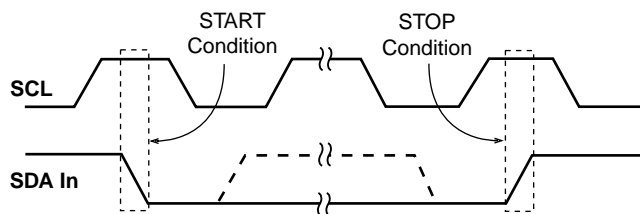

2025 Fig02 1.0

FIGURE 2. START AND STOP CONDITIONS



S4242/S42WD42/S4261/S42WD61

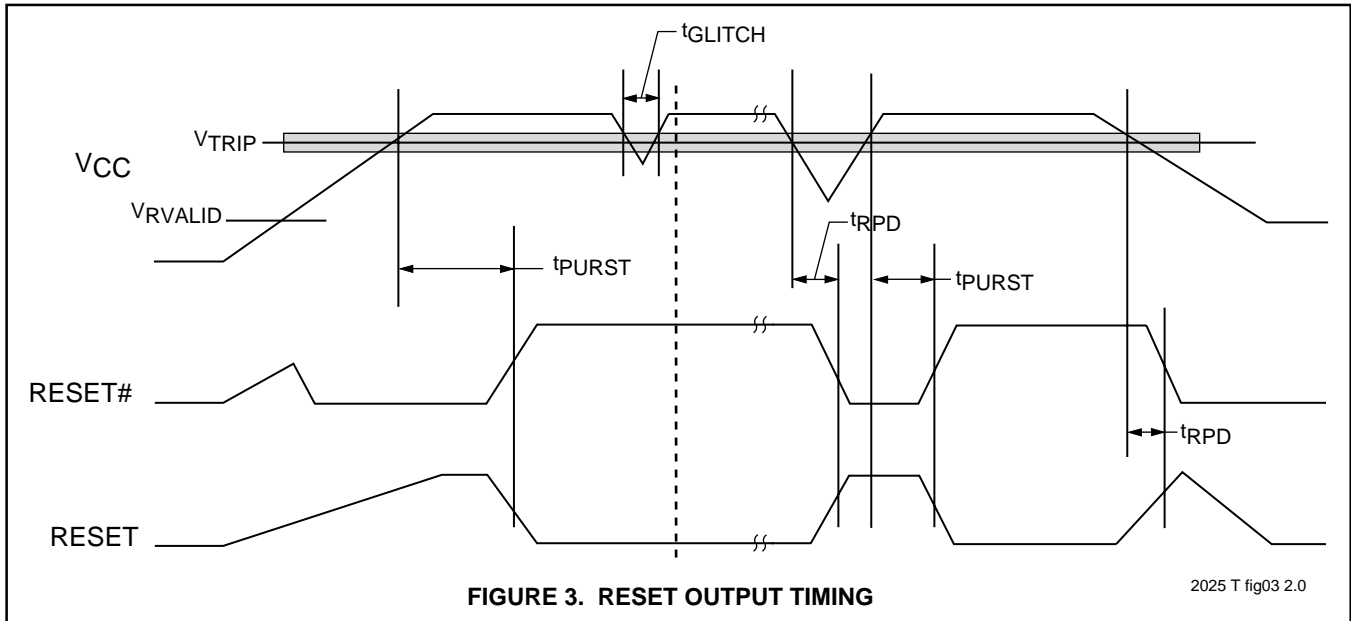

RESET CIRCUIT AC and DC ELECTRICAL CHARACTERISTICS

$T_A = -40^\circ\text{C}$ to $+85^\circ\text{C}$

Symbol	Parameter	Part no. Suffix	Min.	Typ.	Max.	Unit
V _{TRIP}	Reset Trip Point	A (or) Blank	4.250	4.375	4.5	V
		B	4.50	4.625	4.75	V
		2.7	2.7	2.9	3.10	V
t _{PURST}	Reset Timeout			200		ms
t _{RPD}	V _{TRIP} to RESET Output Delay				5	µs
V _{RVALID}	RESET Output Valid to V _{CC} min. Guarantee		1			V
t _{GLITCH}	Glitch Reject Pulse Width note 1			30		ns
V _{OLRS}	RESET Output Low Voltage I _{OL} = 1mA				0.4	V
V _{OHRS}	RESET High Voltage Output I _{OH} = 800µA		V _{CC} -0.75			V
V _{LULH}	V _{SENSE} Under-voltage threshold low to high		1.20	1.25	1.30	V
V _{UHL}	V _{SENSE} Under-voltage threshold high to low		1.20	1.25	1.30	V
V _{LH}	V _{SENSE} Over-voltage threshold low to high		1.20	1.25	1.30	V
V _{OHL}	V _{SENSE} Over-voltage threshold high to low		1.20	1.25	1.30	V
t _{VD1}	Delay to V _{LOW} Active				5	µs
t _{VD2}	Delay to V _{LOW} Released				5	µs
t _{WDTO}	Watchdog timeout Period (S42WD61) (S42WD42)			1600		ms

2025 PGM T5.2

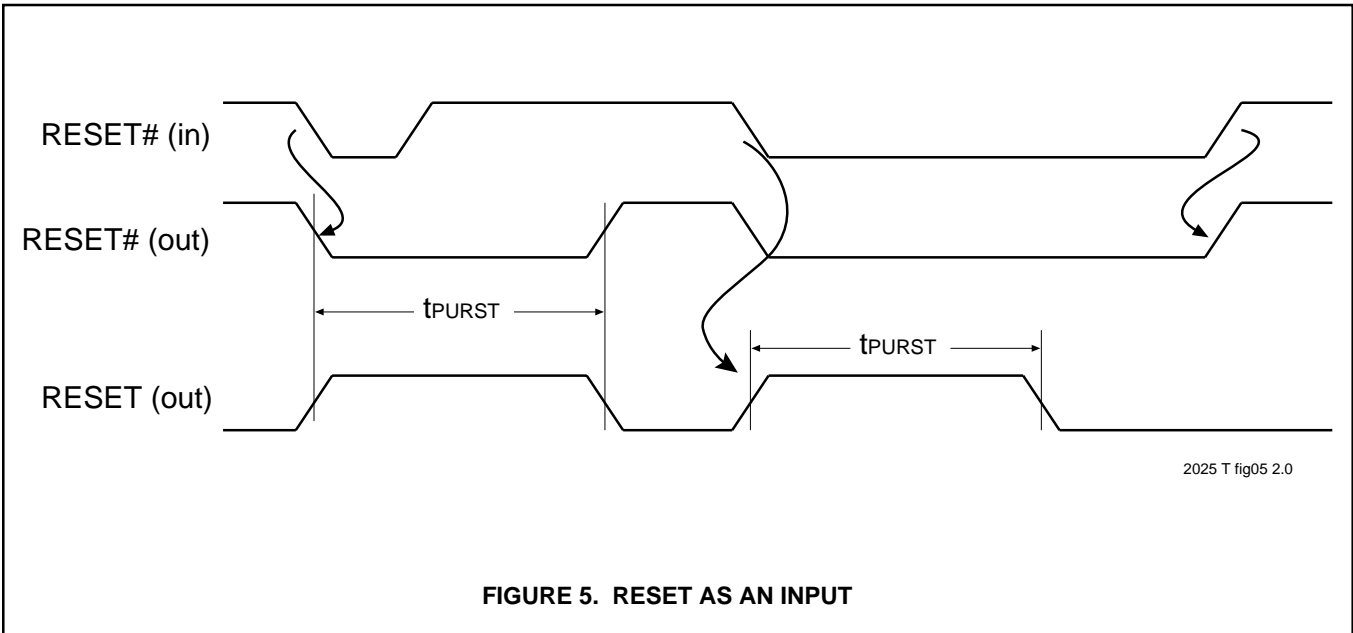
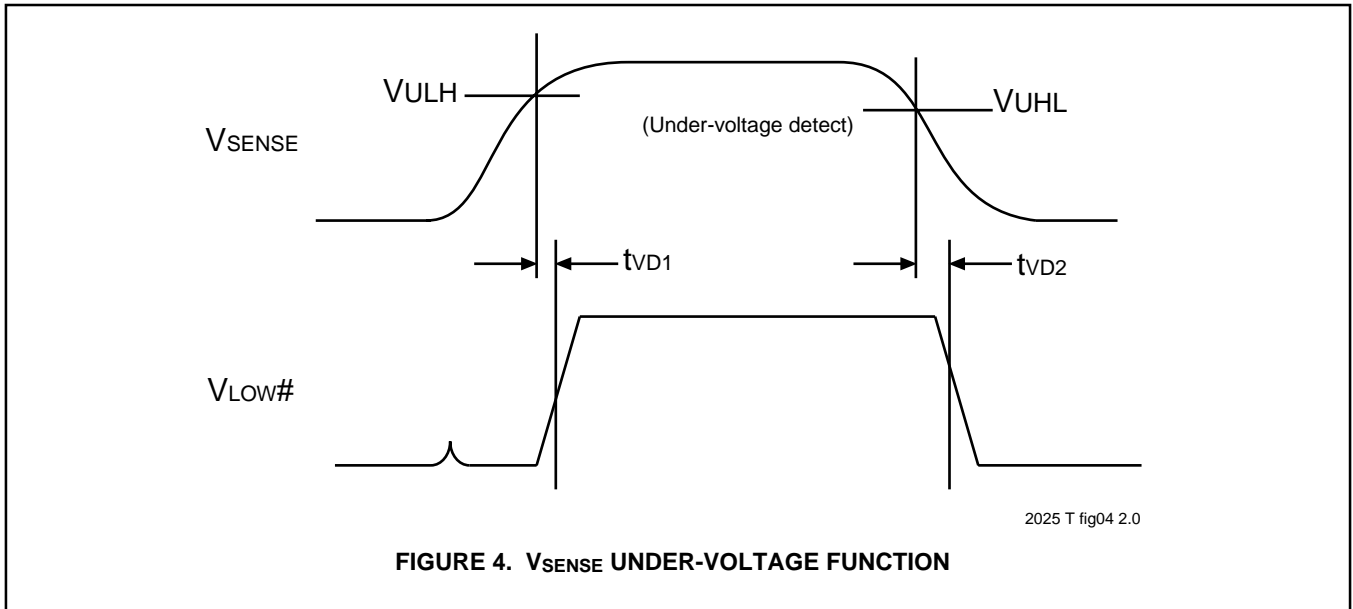



S4242/S42WD42/S4261/S42WD61

PIN CONFIGURATIONS

8-Pin SOIC

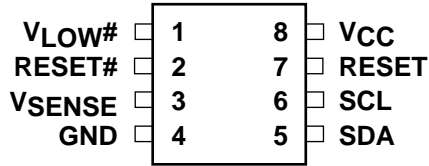

2025 T PCon 2.0

PIN NAMES

Symbol	Pin	Description
$V_{LOW\#}$	1	Open drain output, active when $V_{SENSE} < 1.24V$
RESET#	2	Active low I/O
V_{SENSE}	3	2nd monitor voltage input. $V_{LOW\#}$ output when $< 1.24V$
GND	4	Analog & digital ground
SDA	5	Serial memory I/O data line
SCL	6	Serial memory clock
RESET	7	Active high I/O
V_{CC}	8	Supply voltage

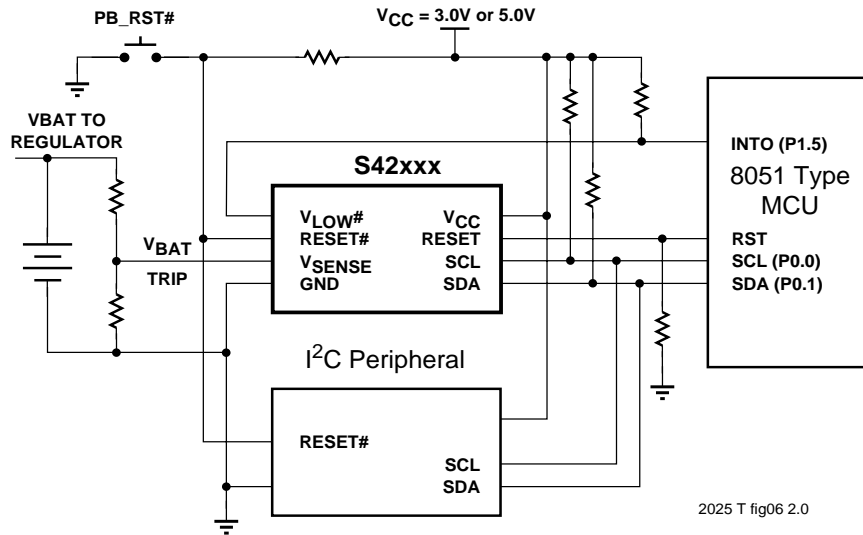

2025 T fig06 2.0

FIGURE 6. TYPICAL SYSTEM CONFIGURATION USING A PUSH BUTTON RESET AND BATTERY MONITOR CIRCUIT

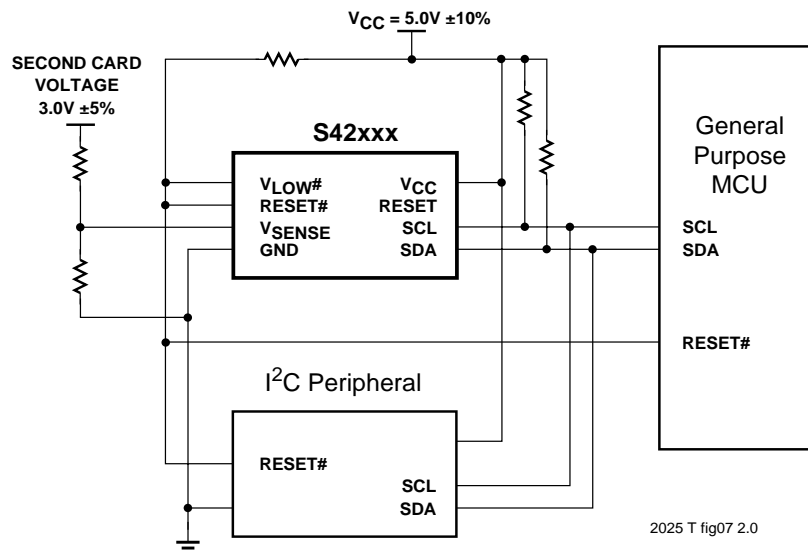

2025 T fig07 2.0

FIGURE 7. TYPICAL SYSTEM CONFIGURATION FOR DUAL RESET WITH V_{CC} MONITOR AND 3.3VOLT MONITOR



PIN DESCRIPTIONS

Serial Clock (SCL) - The SCL input is used to clock data into and out of the device. In the WRITE mode, data must remain stable while SCL is HIGH. In the READ mode, data is clocked out on the falling edge of SCL.

Serial Data (SDA) - The SDA pin is a bidirectional pin used to transfer data into and out of the device. Data may change only when SCL is LOW, except START and STOP conditions. It is an open-drain output and may be wire-ORed with any number of open-drain or open-collector outputs.

RESET# - RESET# is an active low open-drain output. It should be tied high through a pull-up resistor connected to V_{CC} . RESET# is an I/O, therefore it may also be used to condition a RESET# signal generated by another device; it can also be used to debounce a pushbutton input.

RESET - RESET is an active high open drain (PFET) output. It should be tied low through a pull-down resistor connected to ground. RESET is an I/O, therefore it may also be used to condition a RESET signal generated by another device.

VSENSE - The V_{SENSE} input is used as a second voltage sensing input. The pin is tied to a comparator that uses the precision internal 1.25V reference.

VLOW# - $V_{LOW\#}$ is an active low open drain output driven low whenever V_{SENSE} is below 1.25V. It is not a timed output and only responds to the state of V_{SENSE} .

ENDURANCE AND DATA RETENTION

The S42xxx is designed for applications requiring 100,000 erase/write cycles and unlimited read cycles. It provides 100 years of secure data retention, with or without power applied, after the execution of 100,000 erase/write cycles.

Reset Controller Description

The S42xxx provides a precision RESET controller that ensures correct system operation during brown-out and power-up/-down conditions. It is configured with two open drain RESET outputs; pin 7 is an active high output and pin 2 is an active low output. For proper operation pin 7 should be tied low through a pull-down resistor while pin 2 should be tied high through a resistor connected to V_{CC} .

During power-up, the RESET outputs remain active until V_{CC} reaches the V_{TRIP} threshold and will continue driving the outputs for t_{PURST} (200 msec) after reaching V_{TRIP} . The RESET outputs will be valid so long as V_{CC} is $> 1.0V$. During power-down, the RESET outputs will begin driving active when V_{CC} falls below V_{TRIP} .

The RESET pins are I/Os; therefore, the S42xxx can act as a signal conditioning circuit for an externally applied reset. The inputs are edge triggered; that is, the RESET input will initiate a reset timeout after detecting a low to high transition and the RESET# input will initiate a reset timeout after detecting a high to low transition. Refer to the applications information section for more details on device operation as a reset conditioning circuit.

Voltage Sensor Description

V_{SENSE} is an auxiliary voltage detection circuit. Its threshold is set at 1.25V and it generates a $V_{LOW\#}$ output for an under-voltage condition. Because the $V_{LOW\#}$ output is open-drain, it can be wire-ORed with the RESET# output or tied directly to an IRQ input on a microcontroller.

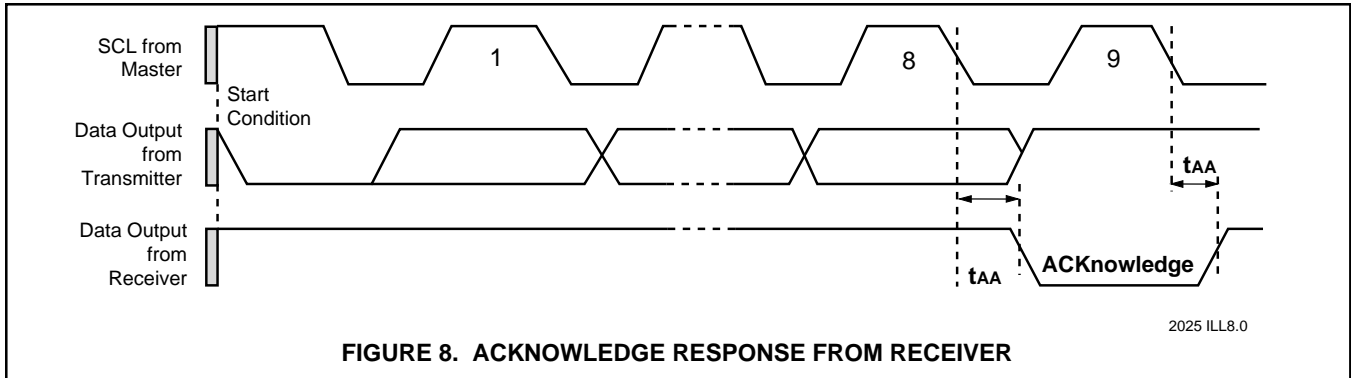

FIGURE 8. ACKNOWLEDGE RESPONSE FROM RECEIVER

CHARACTERISTICS OF THE I²C BUS

General Description

The I²C bus was designed for two-way, two-line serial communication between different integrated circuits. The two lines are: a serial data line (SDA), and a serial clock line (SCL). The SDA line must be connected to a positive supply by a pull-up resistor, located somewhere on the bus (See Figure 6). Data transfer between devices may be initiated with a START condition only when SCL and SDA are HIGH (bus is not busy).

Input Data Protocol

One data bit is transferred during each clock pulse. The data on the SDA line must remain stable during clock HIGH time, because changes on the data line while SCL is HIGH will be interpreted as start or stop condition, refer to Figure 2.

START and STOP Conditions

When both the data and clock lines are HIGH, the bus is said to be not busy. A HIGH-to-LOW transition on the data line, while the clock is HIGH, is defined as the “START” condition. A LOW-to-HIGH transition on the data line, while the clock is HIGH, is defined as the “STOP” condition (See Figure 2).

DEVICE OPERATION

The S42xxx is a 16K-bit serial E²PROM. The device supports the I²C bidirectional data transmission protocol. The protocol defines any device that sends data onto the bus as a “transmitter” and any device which receives data as a “receiver.” The device controlling data transmission is called the “master” and the controlled device is called the “slave.” In all cases, the S42xxx will be a “slave” device, since it never initiates any data transfers.

Acknowledge (ACK)

Acknowledge is a software convention used to indicate successful data transfers. The transmitting device, either the master or the slave, will release the bus after transmitting eight bits. During the ninth clock cycle, the receiver

will pull the SDA line LOW to ACKnowledge that it received the eight bits of data (See Figure 8).

The S42xxx will respond with an ACKnowledge after recognition of a START condition and its slave address byte. If both the device and a write operation are selected, the S42xxx will respond with an ACKnowledge after the receipt of each subsequent 8-bit word.

In the READ mode, the S42xxx transmits eight bits of data, then releases the SDA line, and monitors the line for an ACKnowledge signal. If an ACKnowledge is detected, and no STOP condition is generated by the master, the S42xxx will continue to transmit data. If an ACKnowledge is not detected, the S42xxx will terminate further data transmissions and awaits a STOP condition before returning to the standby power mode.

Device Addressing

Following a start condition the master must output the address of the slave it is accessing. The most significant four bits of the slave address are the device type identifier (see figure 7). For the S42xxx this is fixed as 1010[B].

Word Address

The next three bits of the slave address are an extension of the array’s address and are concatenated with the eight bits of address in the word address field, providing direct access to the 2,048 x8 array of the S4261 and S42WD61. A10 and A9 are “Don’t Care” on S4242 and S42WD42.

Read/Write Bit

The last bit of the data stream defines the operation to be performed. When set to “1,” a read operation is selected; when set to “0,” a write operation is selected.

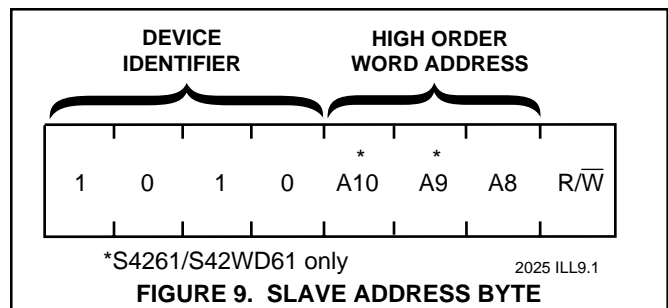

FIGURE 9. SLAVE ADDRESS BYTE



WRITE OPERATIONS

The S42xxx allows two types of write operations: byte write and page write. The byte write operation writes a single byte during the nonvolatile write period (t_{WR}). The page write operation allows up to 16 bytes in the same page to be written during t_{WR} .

Byte WRITE

After the slave address is sent (to identify the slave device, specify high order word address and a read or write operation), a second byte is transmitted which contains the low 8 bit addresses of any one of the 2,048 words in the array.

Upon receipt of the word address, the S42xxx responds with an ACKnowledge. After receiving the next byte of data, it again responds with an ACKnowledge. The master then terminates the transfer by generating a STOP condition, at which time the S42xxx begins the internal write cycle.

While the internal write cycle is in progress, the S42xxx inputs are disabled, and the device will not respond to any requests from the master. Refer to Figure 10 for the address, ACKnowledge and data transfer sequence.

Page WRITE

The S42xxx is capable of a 16-byte page write operation. It is initiated in the same manner as the byte-write operation, but instead of terminating the write cycle after the first data word, the master can transmit up to 15 more words of data. After the receipt of each word, the S42xxx will respond with an ACKnowledge.

The S42xxx automatically increments the address for subsequent data words. After the receipt of each word, the four low order address bits are internally incremented by one. The high order five bits of the address byte remain constant. Should the master transmit more than sixteen words, prior to generating the STOP condition, the address counter will “roll over,” and the previously written data will be overwritten. As with the byte-write operation, all inputs are disabled during the internal write cycle. Refer to Figure 10 for the address, ACKnowledge and data transfer sequence.

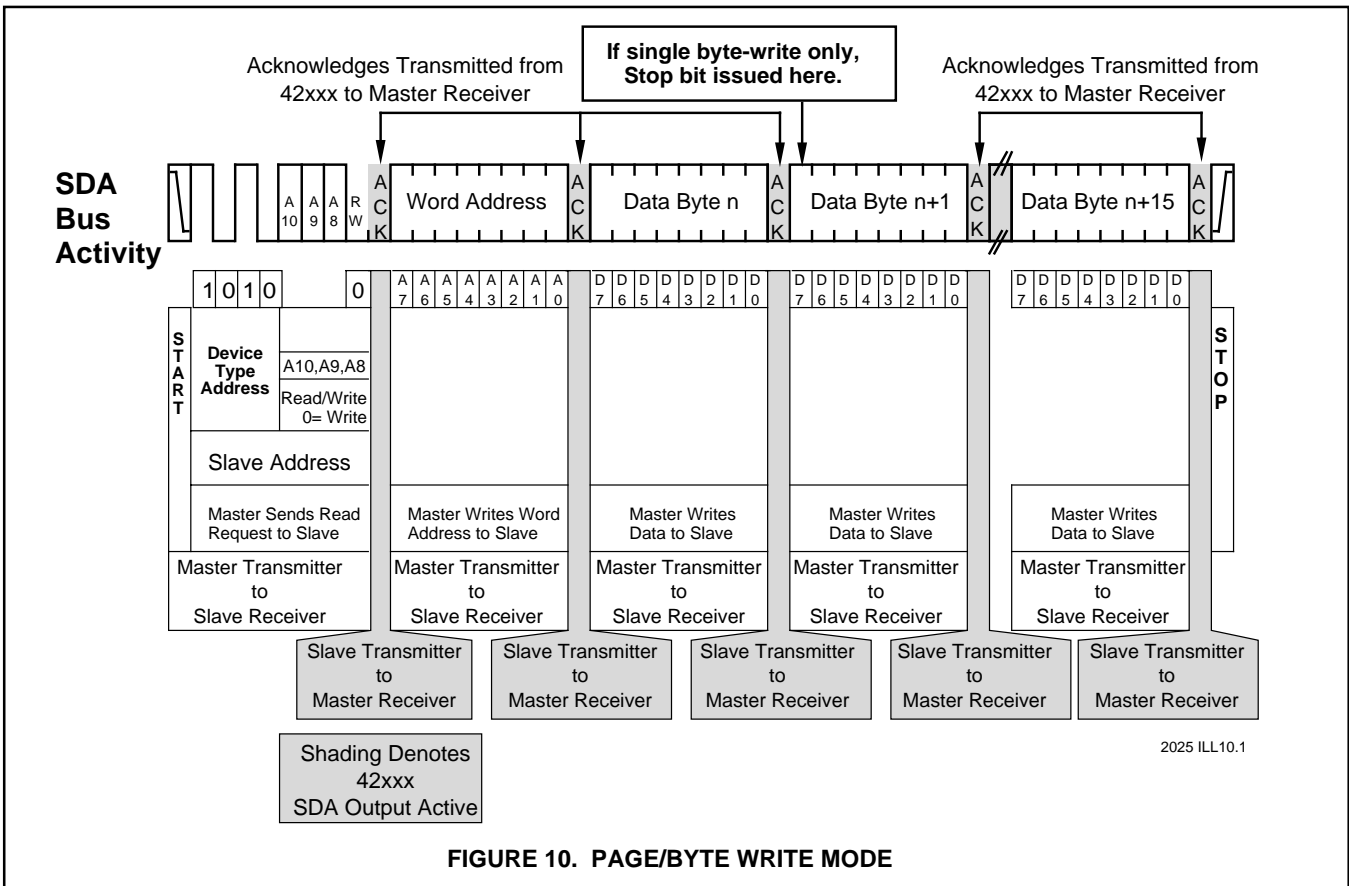



Acknowledge Polling

When the S42xxx is performing an internal WRITE operation, it will ignore any new START conditions. Since the device will only return an acknowledge after it accepts the START, the part can be continuously queried until an acknowledge is issued, indicating that the internal WRITE cycle is complete.

To poll the device, give it a START condition, followed by a slave address for a WRITE operation (See Figure 9).

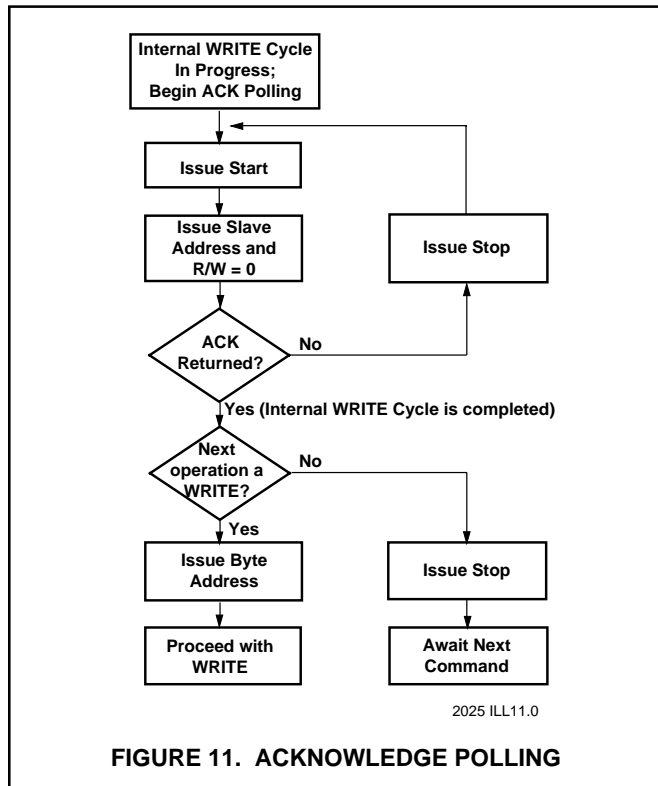

READ OPERATIONS

Read operations are initiated with the R/W bit of the identification field set to "1." There are four different read options:

1. Current Address Byte Read
2. Random Address Byte Read
3. Current Address Sequential Read
4. Random Address Sequential Read

Current Address Byte Read

The S42xxx contains an internal address counter which maintains the address of the last word accessed, incremented by one. If the last address accessed (either a read or write) was to address location n, the next read operation would access data from address location n+1 and increment the current address pointer. When the S42xxx receives the slave address field with the R/W bit set to "1," it issues an acknowledge and transmits the 8-bit word stored at address location n+1.

The current address byte read operation only accesses a single byte of data. The master does not acknowledge the transfer, but does generate a stop condition. At this point, the S42xxx discontinues data transmission. See Figure 12 for the address acknowledge and data transfer sequence.

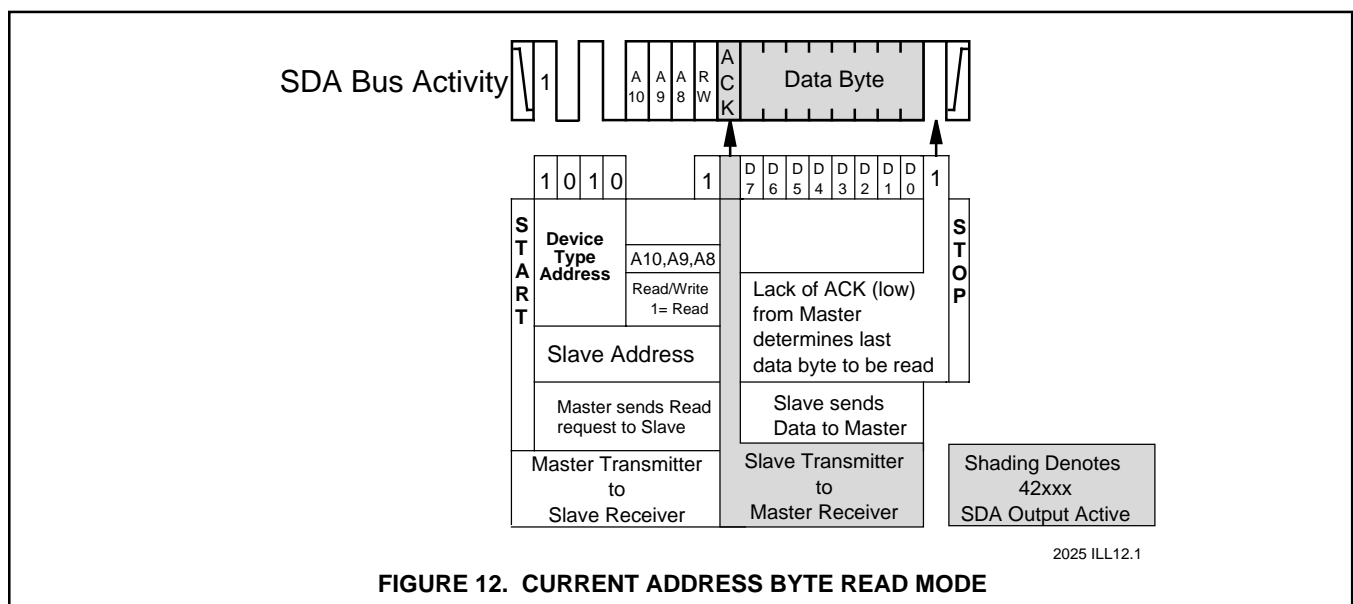



Random Address Byte Read

Random address read operations allow the master to access any memory location in a random fashion. This operation involves a two-step process. First, the master issues a write command which includes the start condition and the slave address field (with the R/W bit set to WRITE) followed by the address of the word it is to read. This procedure sets the internal address counter of the S42xxx to the desired address.

After the word address acknowledge is received by the master, the master immediately reissues a start condition followed by another slave address field with the R/W bit set to READ. The S42xxx will respond with an acknowledge and then transmit the 8-data bits stored at the addressed location. At this point, the master does not acknowledge the transmission but does generate the stop condition. The S42xxx discontinues data transmission and reverts to its standby power mode. See Figure 13 for the address, acknowledge and data transfer sequence.

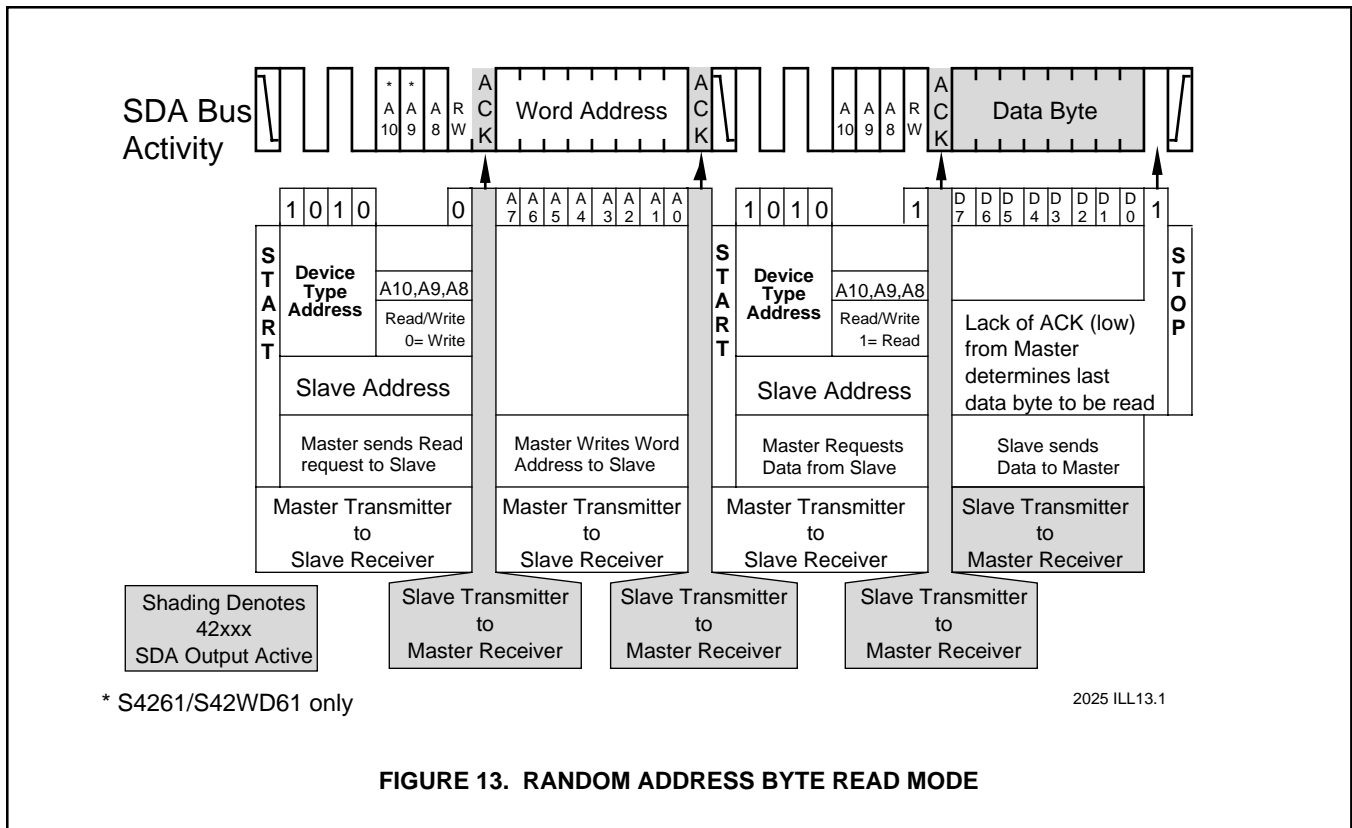

FIGURE 13. RANDOM ADDRESS BYTE READ MODE



Sequential READ

Sequential READs can be initiated as either a current address READ or random access READ. The first word is transmitted as with the other byte read modes (current address byte READ or random address byte READ); however, the master now responds with an ACKnowledge, indicating that it requires additional data from the S42xxx. The S42xxx continues to output data for each ACKnowledge received. The master terminates the sequential READ operation by not responding with an ACKnowledge, and issues a STOP conditions.

During a sequential read operation, the internal address counter is automatically incremented with each acknowledge signal. For read operations, all address bits are incremented, allowing the entire array to be read using a single read command. After a count of the last memory address, the address counter will 'roll-over' and the memory will continue to output data. See Figure 14 for the address, acknowledge and data transfer sequence.

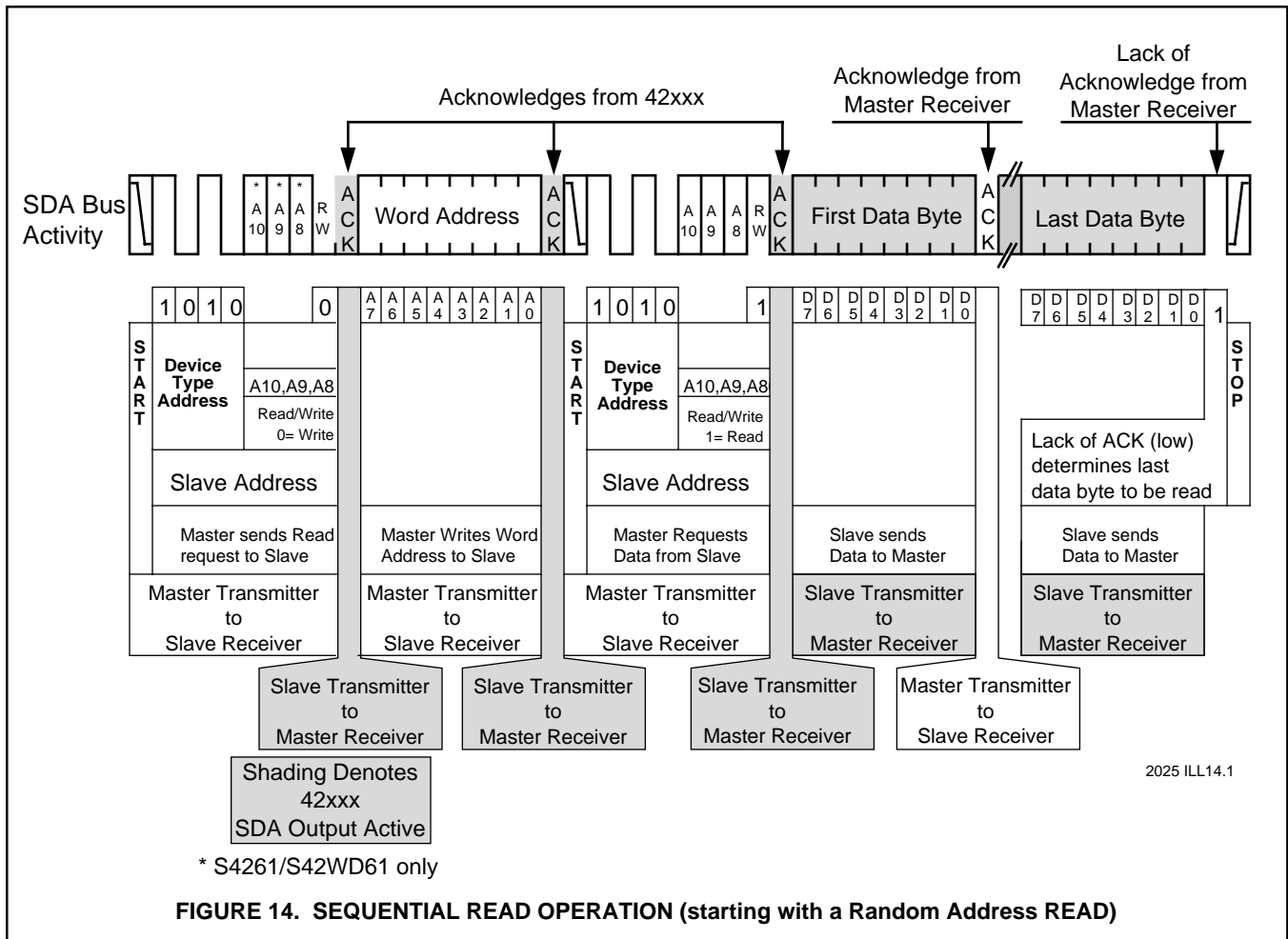

FIGURE 14. SEQUENTIAL READ OPERATION (starting with a Random Address READ)



S4242/S42WD42/S4261/S42WD61

Watchdog Timer Operation

The S42WD42/S42WD61 has a watchdog timer with a nominal timeout period of 1.6 seconds. Whenever the watchdog times out it will generate a reset output on both RESET# and RESET. The watchdog timer will reset to t_0 whenever the S42WD42/S42WD61 issues an ACKnowledge. Therefore, the host system will need to issue a start condition, followed by a valid address and command. It can be a normal command as in the sequence of reading or writing to the memory, or it can be a dummy command issued solely for the purpose of resetting the watchdog timer. Refer to Figure 17 for detailed sequence of operations.

The watchdog timer will be held in the reset state during power-on while V_{CC} is less than V_{TRIP} . Once V_{CC} exceeds

V_{TRIP} , the watchdog will continue to be held in a reset state for the duration of t_{PURST} . After t_{PURST} , the timer will be released and begin counting.

If either reset input is asserted the watchdog timer will be reset and remain in the reset condition until either t_{PURST} has expired or the reset input is released, whichever is longer.

If the watchdog times out and no action is taken by the host, the S42xxx will drive the reset outputs active for the duration of t_{PURST} at which point it will release the outputs and begin the watchdog timer again. Refer to Figure 18 for detailed sequence of operations.

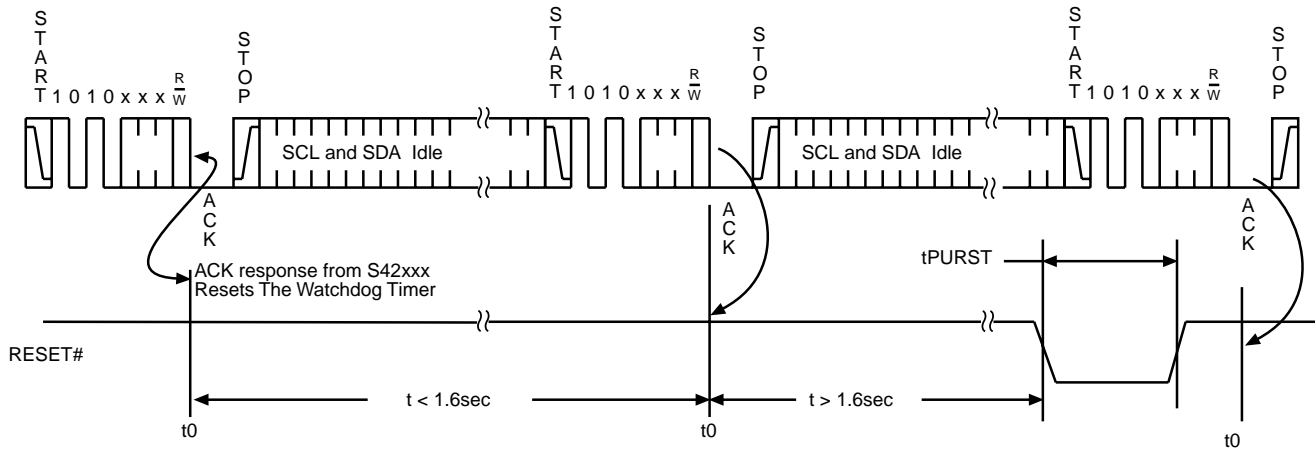

2025 T fig17 2.0

FIGURE 17. SEQUENCE ONE

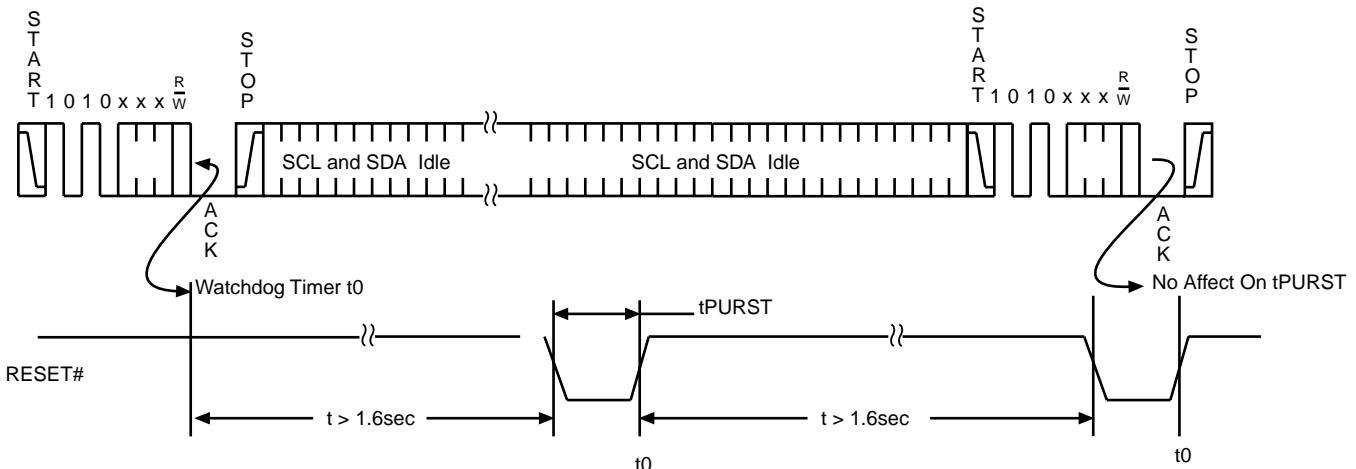

2025 T fig18 2.0

FIGURE 18. SEQUENCE TWO



S4242/S42WD42/S4261/S42WD61

8 Pin SOIC (Type S) Package JEDEC (150 mil body width)

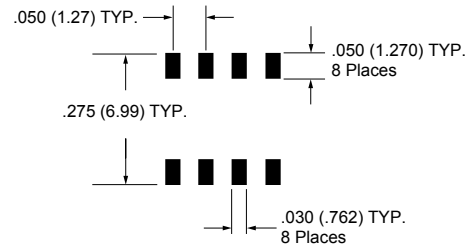
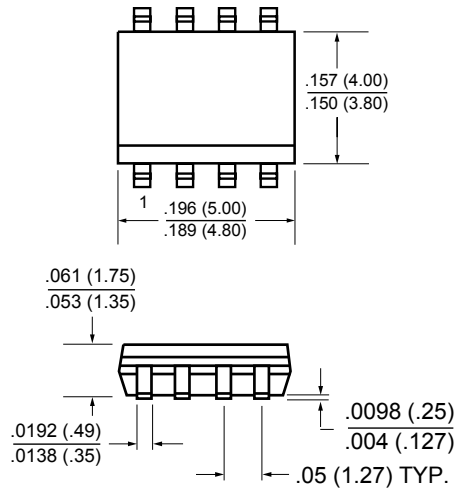

FOOTPRINT

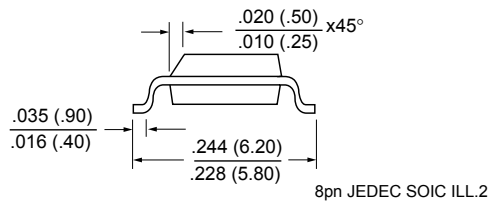



S4242/S42WD42/S4261/S42WD61

ORDERING INFORMATION

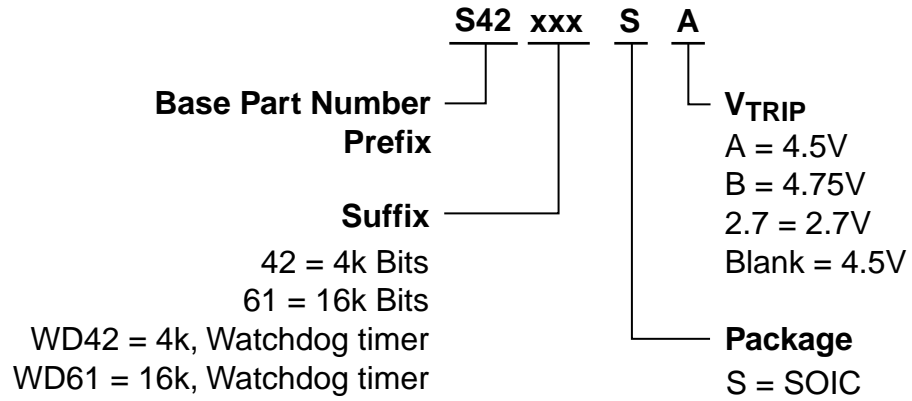



NOTICE

SUMMIT Microelectronics, Inc. reserves the right to make changes to the products contained in this publication in order to improve design, performance or reliability. SUMMIT Microelectronics, Inc. assumes no responsibility for the use of any circuits described herein, conveys no license under any patent or other right, and makes no representation that the circuits are free of patent infringement. Charts and schedules contained herein reflect representative operating parameters, and may vary depending upon a user's specific application. While the information in this publication has been carefully checked, SUMMIT Microelectronics, Inc. shall not be liable for any damages arising as a result of any error or omission.

SUMMIT Microelectronics, Inc. does not recommend the use of any of its products in life support or aviation applications where the failure or malfunction of the product can reasonably be expected to cause any failure of either system or to significantly affect their safety or effectiveness. Products are not authorized for use in such applications unless SUMMIT Microelectronics, Inc. receives written assurances, to its satisfaction, that: (a) the risk of injury or damage has been minimized; (b) the user assumes all such risks; and (c) potential liability of SUMMIT Microelectronics, Inc. is adequately protected under the circumstances.

© Copyright 2000 SUMMIT Microelectronics, Inc.

I²C is a trademark of Philips Corporation.