

Six-Channel Active DC Output Controller, Monitor, Marginer and Sequencer with Sequence-Link™

FEATURES & APPLICATIONS

- Extremely accurate ($\pm 0.2\%$) Active DC Output Control (ADOC™)
- Sequence-Link™ provides sequencing of up to 48 channels
- ADOC automatically adjusts supply output voltage level under all DC load conditions
- Monitors, controls, and margins up to 6 supplies from 0.3V to 5.5V with 1.25V Vref
- Programmable power-on/-off sequencing
- Operates from any intermediate bus supply from 6V to 14V and from 2.7V to 5.5V
- Monitors 12V input VDD and temperature sensor
- Wide margin/ADOC range from 0.3V to VDD
- Monitors two general-purpose 10-bit ADC inputs
- I²C 2-wire serial bus for programming configuration and monitoring status, including 10-bit ADC conversion results
- 2 programmable Under Voltage (UV) and Over Voltage (OV) threshold limits for each of 11 monitored inputs
- 2k-bit general purpose nonvolatile memory

Applications

- Monitor/control distributed and POL supplies
- Multi-voltage processors, DSPs, ASICs used in telecom, CompactPCI or server systems

INTRODUCTION

The SMM766B is an Active DC Output power supply Controller (ADOC™) that monitors, margins, and cascade sequences. The ADOC feature is unique and maintains extremely accurate settings of system supply voltages to within $\pm 0.2\%$ under full load. The SMM766B actively controls up to 6 DC/DC converters and can be linked with up to 7 other Sequence-Link™ devices to accommodate sequencing of up to 48 channels. Control of the DC-DC converters is accomplished through the use of a Trim or Regulator VADJ/FB pin to adjust the output voltage. For system test, the part also controls margining of the supplies using I²C commands. It can margin supplies with either positive or negative control within a range of 0.3V to VDD, depending on the specified range of the converter. The SMM766B also intelligently sequences or cascades the power supplies on and off in any order using enable outputs with programmable polarity. It can operate off any intermediate bus supply ranging from 6V to 14V or from 5.5V to as low as 2.7V. The part monitors 6 power supply channels as well as VDD, 12V input, two general-purpose analog inputs and an internal temperature sensor using a 10-bit ADC. The 10-bit ADC can measure the value on any one of the monitor channels and output the data via the I²C bus. A host system can communicate with the SMM766B status register, margining and utilize 2K-bits of nonvolatile memory.

SIMPLIFIED APPLICATIONS DRAWING

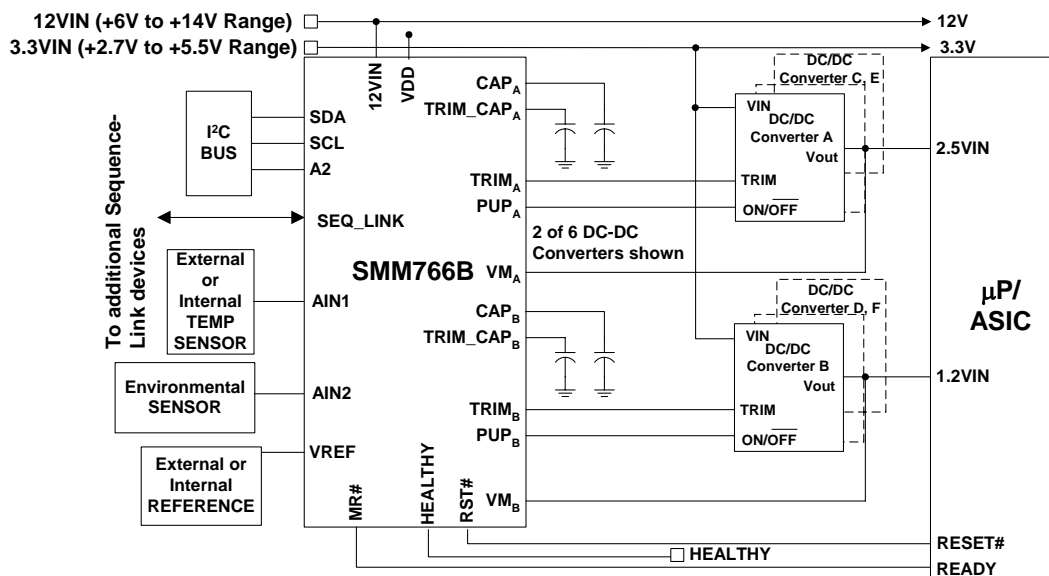

Figure 1 – Applications schematic using the SMM766B controller to actively control the output levels of up to 6 DC/DC converters while also providing power-on/off, cascade sequencing and output margining.

Note: This is an applications example only. Some pins, components and values are not shown.

TABLE OF CONTENTS

General Description.....	3	Recommended Use Of The Power On Pin.....	20
Internal Functional Block Diagram.....	4	Auto Monitor Function.....	21-25
Pin Descriptions.....	5-6	Under-voltage Lockout.....	26
Package And Pin Configuration.....	7	Applications Schematic.....	27
Absolute Maximum Ratings.....	8	Development Hardware & Software.....	28
Recommended Operating Conditions.....	8	I²C Programming Information	
DC Operating Characteristics.....	8-11	Serial Interface.....	29
AC Operating Characteristics.....	12	Write.....	29
I ² C 2-Wire Serial Interface AC Operating		Read.....	29
Characteristics-100/400khz.....	13	Write Protection.....	30
Timing Diagrams.....	13-14	Configuration Registers.....	30
DEVICE OPERATION		General-Purpose Memory.....	30
Power Supply.....	15	Command And Status Registers.....	30
Modes Of Operation.....	15	ADC Conversions.....	30
Active DC Output Control.....	15-16	Graphical User Interface (GUI).....	30
Power-On Cascade Sequencing.....	16	Write Protection Register Write.....	31
Ongoing Operations-Monitoring Mode.....	17	Configuration Register Read/Write.....	31-32
Temperature Sensor Accuracy.....	17	General-Purpose Memory Read/Write.....	33
Automonitor.....	18	Command And Status Register Read/Write.....	34
Margining.....	18	ADC Conversion Read.....	34
Power-Off Cascade Sequencing.....	18	Default Configuration Register Settings.....	35
Force-Shutdown.....	19	Package.....	36
Linked Operation.....	19	Part Marking.....	37
Restart.....	19	Ordering Information.....	37
I ² C Power-Off Control.....	19	Terminology And Definitions.....	38
		Legal Notice.....	39

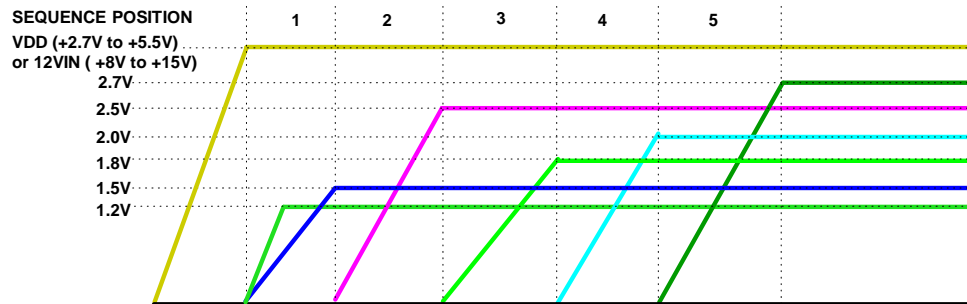

Figure 2 – Example power supply sequencing and system start-up initialization using the SMM766B. Cascade sequencing ensures that all supplies in the previous sequence position are valid before the next channel is released. Using the SMM766B any order of supply sequencing can be applied.

GENERAL DESCRIPTION

The SMM766B is a highly integrated and accurate power supply controller, monitor, and sequencer. Each device has the ability to automatically control, monitor and cascade sequence up to 6 power supplies. In addition, the SMM766B includes Sequence-Link™ a feature that allows for the seamless integration of other Sequence-Link devices to accommodate sequencing of up to 48 channels. The SMM766B can monitor the VDD input, the 12V input, two general-purpose analog inputs, and the internal temperature sensor. The SMM766B has four operating modes: power-on sequencing mode, monitor mode, supply margining mode using Active DC Output Control (ADOC™), and power-off sequencing mode.

Power-on sequencing is initiated by the rising edge of the PWR_ON pin. During power-on sequencing the SMM766B will sequence the power supply channels on, in any order, by activating the PUP outputs and monitoring the respective converter voltages to ensure cascading of the supplies. Cascade sequencing is the ability to hold off the next sequenced supply until the first supply reaches a programmed threshold. A programmable sequence termination timer can be set to disable all channels if the power-on sequence stalls. Once all supplies have sequenced on and the voltages are above the UV settings, the ADOC, if enabled, will bring the supply voltages to their nominal settings. During this mode, the HEALTHY output will remain inactive and the RST# output will remain active.

Once the power-on sequencing mode is complete, the SMM766B enters monitor mode. In the monitor mode, the SMM766B starts the ADOC control of the supplies and adjusts the output voltage to the programmed setting under all load conditions, especially useful for supplies without sense lines. Typical converters have $\pm 2\%$ accuracy ratings for their output voltage; the ADOC feature of the SMM766B increases the accuracy to $\pm 0.2\%$ (using a $\pm 0.1\%$ external voltage

reference). The part also enables the triggering of outputs by monitored fault conditions. The 10-bit ADC cycles through all 11 channels every 2ms and checks the conversions against the programmed threshold limits. The results can be used to trigger RST#, HEALTHY and FAULT# outputs as well as to initiate a Fault-Triggered power-off or force-shutdown operation.

While the SMM766B is in its monitoring mode, an I²C command to margin the supply voltages can bring the part into margining mode. In margining mode the SMM766B can margin 6 supply voltages in any combination of nominal, high and low voltage settings using the ADOC feature, all to within $\pm 0.2\%$ using a $\pm 0.1\%$ external reference. The margin high and low voltage settings can range from 0.3V to VDD around the converters' nominal output voltage setting depending on the specified margin range of the DC-DC converter. During this mode the HEALTHY output is always active and the RST# output is always inactive regardless of the voltage threshold limit settings and triggers. Furthermore, the triggers for power-off and force-shutdown are temporarily disabled.

The power-off sequencing mode can only be entered while the SMM766B is in the monitoring mode. It can be initiated by either bringing the PWR_ON pin low, through I²C control, or triggered by a channel exceeding its programmed thresholds. Once power-off is initiated, it will disable the ADOC function and sequence the PUP outputs off in the reverse order as power-on sequencing. To ensure cascading of the supplies during power-off sequencing all supplies will be monitored as they turn off. The sequence termination timer performs a forced-shutdown operation if power-off sequencing stalls.

INTERNAL FUNCTIONAL BLOCK DIAGRAM

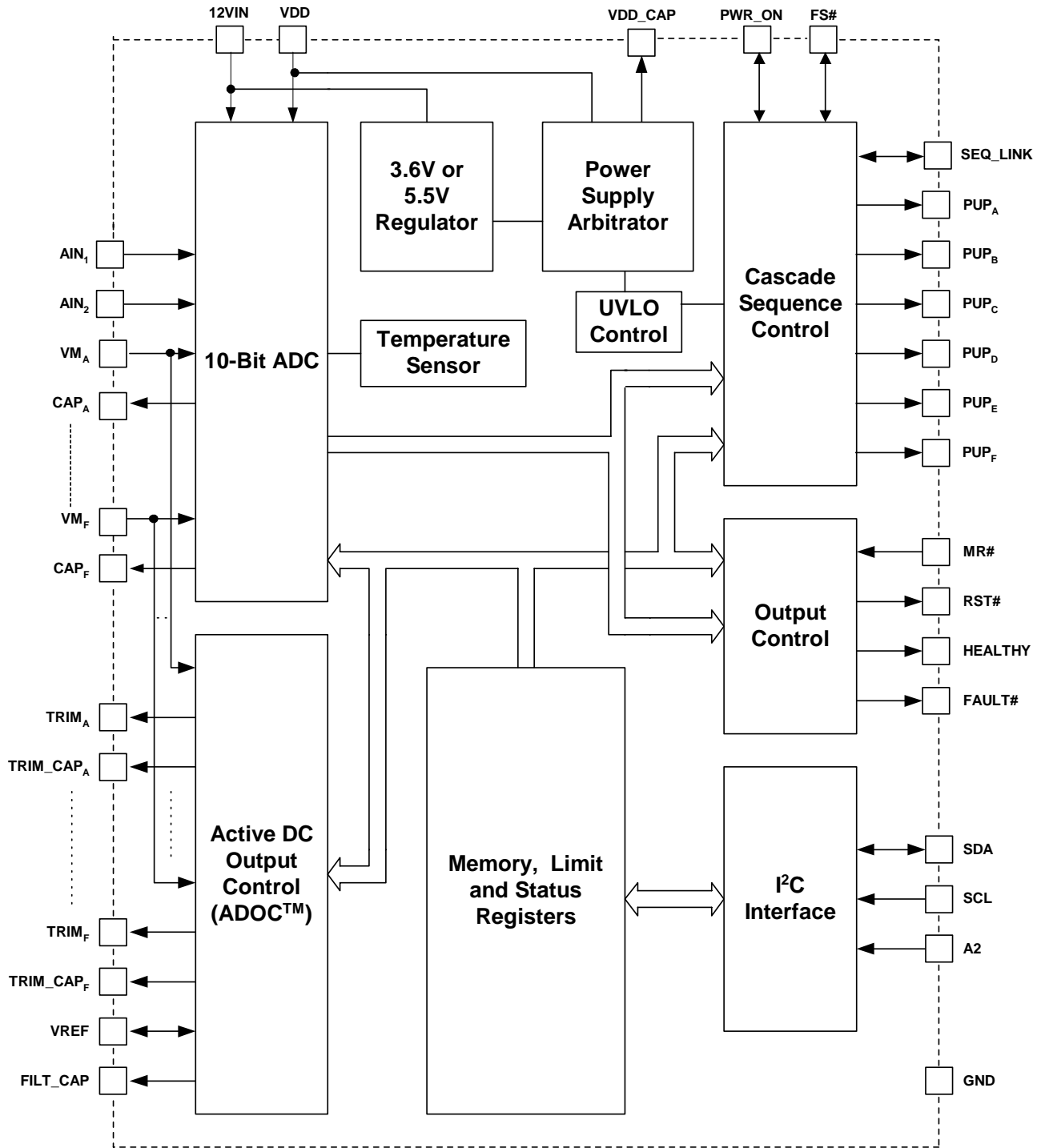

Figure 3 – SMM766B Internal Functional Block Diagram.

PIN DESCRIPTIONS

Pin Number	Pin Type	Pin Name	Pin Description
1	DATA	SDA	SDA (Serial Data) is an open drain bi-directional pin used as the I ² C data line.
2	CLK	SCL	SCL (Serial Clock) is an open drain input pin used as the I ² C Clock line.
3	IN	A2	The A2 (Address bit 2) pin is biased either to VDD_CAP or GND. When communicating with the SMM766B over the 2-wire I ² C bus, A2 provides a mechanism for assigning a unique bus address.
4	IN	MR#	MR# (Manual Reset) is an active low input. When asserted the RST# output will become active. When de-asserted the RST# output will go inactive immediately after a reset timeout period (t _{RTO}) if there are no RST# trigger sources active. This timeout period makes it suitable to use as a pushbutton for manual reset purposes.
5	I/O	PWR_ON	PWR_ON (Power On) is an open drain bi-directional pin. On the rising edge of PWR_ON the part will sequence the supplies on, during the falling edge the part will sequence the supplies off. This pin must be tied high through an external pull-up resistor. Note: The SMM766B does not monitor for faults during power-on/off sequencing.
6	I/O	FS#	FS# (Force Shutdown) is an open drain active low bi-directional pin. FS# is used to immediately turn off all converter enable signals (PUP outputs) when a fault is detected. Whenever FS# is asserted PWR_ON will automatically be pulled low as well. This pin must be tied high through an external pull-up resistor.
7	OUT	FAULT#	The FAULT# pin is an active low open drain output. Active when a programmed fault condition exists on AIN1, AIN2, or the internal temperature sensor. When used, FAULT# should be pulled high through an external pull-up resistor.
8	OUT	HEALTHY	HEALTHY is an active high open drain output. Active when all programmed power supply inputs and monitored inputs are within OV and UV limits and ADOC has begun. When used, HEALTHY should be pulled high through an external pull-up resistor.
9	OUT	RST#	RST# (Reset) is an active low open drain output pin. Active when a programmed fault condition exists on any power supply inputs or monitored inputs, when MR# is active, or when ADOC is not ready. RST# has a programmable timeout period with options for 0.64ms, 25ms, 100ms and 200ms. When used, RST# should be pulled high through an external pull-up resistor.
10	IN	AIN1	AIN1 (Analog Input 1) is a general-purpose monitored analog input.
11	IN	AIN2	AIN2 (Analog Input 2) is a general-purpose monitored analog input.
12	GND	GND	Ground.

PIN DESCRIPTIONS (Cont.)

Pin Number	Pin Type	Pin Name	Pin Description
13	I/O	SEQ_LINK	SEQ_LINK (Sequence-Link™) is an open drain bi-directional pin. This pin should be attached to other Sequence-Link devices, during linked operation. SEQ_LINK must be pulled high through an external pull-up resistor when multiple Sequence-Link devices are used. When the SMM766B is not used with another Sequence-Link device, SEQ_LINK should be tied directly to ground.
14	I/O	VREF	VREF (Voltage Reference) is a bi-directional analog pin. VREF is used for Active DC Output Control and margining. VREF can be programmed to output the internal 1.25V reference.
15	CAP	FILT_CAP	FILT_CAP (Filter Capacitor) is an external capacitor input used to filter VM _x inputs.
41,36, 31,26, 21,16	IN	VM _x	VM _x (Voltage Monitor) pins are analog inputs. These pins are normally attached to the positive converter sense line, VM _A through VM _F .
42,37, 32,27, 22,17	CAP	CAP _x	External capacitor input used to filter the VM _x inputs to the 10-bit ADC, CAP _A through CAP _F . This provides an RC filter where R = 25kΩ..
43,38, 33,28, 23,18	OUT	PUP _x	PUP _x (Power Up Permitted) pins are programmable active high/low open drain converter enable output, PUP _A through PUP _F .
44,39, 34,29, 24,19	OUT	TRIM _x	Output voltage used to control the output of DC/DC converters, TRIM _A through TRIM _F .
45,40, 35,30, 25,20	CAP	TRIM_CAP _x	TRIM_CAP _x is an analog output pin used to control the output of DC/DC converters. If the ADOC/margining functionality is not used on a channel the associated TRIM_CAP _x pin should be left floating. There are 6 TRIM_CAP _x pins, TRIM_CAP _A through TRIM_CAP _F .
46	PWR	VDD	Power supply of the part
47	PWR	12VIN	12VIN (12 Volt Input) is a power supply input internally regulated to either 3.6V or 5.5V.
48	CAP	VDD_CAP	VDD_CAP (VDD Capacitor) is an external capacitor input used to filter the internal supply.

PACKAGE AND PIN CONFIGURATION

48 LEAD TQFP



ABSOLUTE MAXIMUM RATINGS

Temperature Under Bias..... -55°C to 125°C
 Storage Temperature..... -65°C to 150°C
 Terminal Voltage with Respect to GND:
 VDD Supply Voltage -0.3V to 6.0V
 12VIN Supply Voltage -0.3V to 15.0V
 PUP_A, through PUP_F..... -0.3V to 15.0V
 All Others -0.3V to V_{DD} + 0.7V
 Output Short Circuit Current 100mA
 Lead Solder Temperature (10 s)..... 300°C
 Junction Temperature 150°C
 ESD Rating per JEDEC 2000V
 Latch-Up testing per JEDEC..... ±100mA

Note A - The device is not guaranteed to function outside its operating rating. Stresses listed under Absolute Maximum Ratings may cause permanent damage to the device. These are stress ratings only and functional operation of the device at these or any other conditions outside those listed in the operational sections of the specification is not implied. Exposure to any absolute maximum rating for extended periods may affect device performance and reliability. Devices are ESD sensitive. Handling precautions are recommended.

OPERATING CONDITIONS

Temperature Range (Industrial)..... -40°C to +85°C
 (Commercial) 0°C to +70°C
 VDD Supply Voltage 2.7V to 5.5V
 12VIN Supply Voltage^B 6.0V to 14.0V
 VIN GND to VDD
 VOUT GND to 14.0V
 Package Thermal Resistance (θ_{JA})
 48-Lead TQFP 80°C/W
 Moisture Classification Level 1 (MSL 1) per J-STD-020. MSL 3 for 100% Sn, RoHS compliant, see ordering information
 Note B – Range depends on internal regulator set to 3.6V or 5.5V see 12VIN specification below.

RELIABILITY CHARACTERISTICS

Data Retention 100 Years
 Endurance..... 100,000 Cycles

DC OPERATING CHARACTERISTIC

(Over recommended operating conditions, unless otherwise noted. All voltages are relative to GND.)

Symbol	Parameter	Notes	Min	Typ	Max	Unit
VDD	Supply voltage		2.7		5.5	V
12VIN	Supply voltage	Internally regulated to 5.5V	10		14	V
		Internally regulated to 3.6V	6		14	V
I _{DD}	Power supply current from VDD	All TRIM pins floating, 12VIN floating		1.4	5	mA
I _{12VIN}	Power supply current from 12VIN	All TRIM pins floating, VDD floating		3	5	mA
TRIM characteristics						
I _{TRIM}	TRIM output current through 100Ω to 1.0V, Note 10	TRIM sourcing maximum current	1.5			mA
		TRIM sinking maximum current	1.5			mA
V _{TRIM}	Margin and ADOC range	Depends on TRIM range of DC-DC converter	VREF/4		VDD	V
TRIM_CAP characteristics						
I _{TRIM_CAP}	TRIM output current through 1uF capacitor to ground, Note 2	Max acceptable board and cap leakage is 50nA		100		nA
All other input and output characteristics						
V _{VDD_CAP}	VDD_CAP voltage	Internally regulated to 3.6V	3.4	3.6	3.8	V
		Internally regulated to 5.5V	5.3	5.5	5.7	V
V _{SENSE}	Positive sense voltage	VM pin	+0.3		VDD_CAP	V
V _{MONITOR}	Monitor threshold step size	VM, AIN1/AIN2 pins		5		mV

DC OPERATING CHARACTERISTICS (CONTINUED)

(Over recommended operating conditions, unless otherwise noted. All voltages are relative to GND.)

Symbol	Parameter	Notes	Min	Typ	Max	Unit
V _{IH}	Input high voltage (MR#, SDA, SCL, PWR_ON, SEQ_LINK, FS#), Note 3	VDD = 2.7V	0.7 x VDD_CAP			V
		VDD = 5.0V	0.7 x VDD_CAP			V
V _{IL}	Input low voltage (MR#, SDA, SCL, PWR_ON, SEQ_LINK, FS#), Note 3	VDD = 2.7V			0.3 x VDD_CAP	V
		VDD = 5.0V			0.3 x VDD_CAP	V
V _{IH}	Input high voltage (MR#, SDA, SCL, PWR_ON, SEQ_LINK, FS#), Notes 3, 10	VDD_CAP = 3.6V	0.7 x VDD_CAP			V
		VDD_CAP = 5.5V	0.7 x VDD_CAP			V
V _{IL}	Input low voltage (MR#, SDA, SCL, PWR_ON, SEQ_LINK, FS#), Notes 3, 10	VDD_CAP = 3.6V			0.3 x VDD_CAP	V
		VDD_CAP = 5.5V			0.3 x VDD_CAP	V
V _{OL}	Open drain outputs (RST#, FS#, PWR_ON, HEALTHY, FAULT#, PUPx, SEQ_LINK)	I _{SINK} = 1mA	0		0.4	V
I _{OL}	Output low current, Note 6		0		1.0	mA
I _{IN}	Leakage current on SDA, SCL	SDA or SCL are at 3.6V			1.0	μA
V _{OLSDA}	Output low voltage for SDA	I _{OLSDA} = 3mA	0		0.4	V
T _{SA}	Internal temperature sensor accuracy, Note 5, 8	Commercial temp range	-4	±4	+4	°C
		Industrial temp range	-6	±6	+6	°C
T _{MONITOR}	Temperature threshold step size	Internal temp sensor		0.25		°C
V _{REF}	Internal 1.25V _{REF} Output Voltage Accuracy	T = +25°C	-0.4		+0.4	%
		T = -40°C to +85°C	-0.8		+0.8	%
Ext V _{REF}	External V _{REF} voltage range		0.5		VDD_CAP	V
ADOC _{ACC}	ADOC (Active DC Output Control)/Margin accuracy	External V _{REF} =1.25V, ±0.1%, Total PUPx I _{SINK} = 6ma, V _{SENSE} ≤ 3.5V, T = 0°C to +50°C	-0.20	±0.1	+0.20	%
		External V _{REF} =1.25V, ±0.1%, Total PUPx I _{SINK} = 6ma, V _{SENSE} ≤ 3.5V, T = 0°C to +70°C	-0.35	±0.1	+0.35	%
		External V _{REF} =1.25V, ±0.1%, Total PUPx I _{SINK} = 6ma, V _{SENSE} ≥ 3.5V, T = 0°C to +50°C	-0.50	±0.3	+0.50	%
		Internal V _{REF} =1.25V, Total PUPx I _{SINK} = 6ma, T = 0°C to +50°C	-0.50	±0.3	+0.50	%

DC OPERATING CHARACTERISTICS (CONTINUED)

(Over recommended operating conditions, unless otherwise noted. All voltages are relative to GND.)

Symbol	Parameter	Notes	Min	Typ	Max	Unit
V _{OUT VALID}	Minimum output valid voltage	VDD_CAP voltage at which the PUP, RST#, HEALTHY and FAULT#, FS#, PWR_ON SEQ_LINK, outputs valid		1		V
UVLO	UVLO (Under Voltage Lockout) threshold, Note 4	VDD_CAP rising		2.6		V
		VDD_CAP falling		2.5		V
I _{VDD_CAP}	Maximum load on VDD_CAP	Note 10			10	mA
AIN1/AIN2 ADC characteristics						
N	Resolution		10			Bits
MC	Missing codes	Minimum resolution for which no missing codes are guaranteed	10			Bits
S/N	Signal-to-noise Ratio	Conversion rate = 500Hz		72		dB
DNL	Differential non-linearity		-1/2		+1/2	LSB
INL	Integral non-linearity	Note 7	-1		+1	LSB
GAIN	Positive full scale gain error	Note 7	-0.5	±0.16	+0.5	%
OFFSET	Offset error	Note 7	-1		+1	LSB
ADC_TC	Full scale temperature coefficient			±15		PPM/°C
I _{MADC}	Analog ADC Input Impedance			10		MΩ
I _{VREF}	V _{REF} input current			250		nA
I _{CVREF}	V _{REF} input capacitance			200		pF
I _{RVREF}	V _{REF} input impedance			1		kΩ
VMA-VMF, VDD ADC characteristics						
Symbol	Parameter	Notes	Min	Typ	Max	Unit
N	Resolution		10			Bits
MC	Missing codes	Minimum resolution for which no missing codes are guaranteed	10			Bits
S/N	Signal-to-noise Ratio	Conversion rate = 500Hz		72		dB
ERR_ADC	Total ADC Error	Total ADC Read Error (Note 11)	-4		+4	LSB
I _{MADC}	Analog ADC Input Impedance	VMA-VMF		100		KΩ
12VIN ADC characteristics						
Symbol	Parameter	Notes	Min	Typ	Max	Unit
N	Resolution		10			Bits
MC	Missing codes	Minimum resolution for which no missing codes are guaranteed	10			Bits
S/N	Signal-to-noise Ratio	Conversion rate = 500Hz		72		dB
ERR_ADC	Total ADC Error	Total ADC Read Error (Note 12)	-4		+4	LSB

- Note 1 – Range depends on internal regulator set to 3.6V or 5.5V see 12VIN specification.
- Note 2 – See Application Note 37, which describes the type of capacitors to use to obtain minimum leakage.
- Note 3 – All logic levels are with respect to the voltage on VDD_CAP, when supplied from VDD; VDD_CAP is equal to VDD, under no load.
- Note 4 – (100mV typical Hysteresis)
- Note 5 – Under certain operating conditions, self-heating could result in additional temperature sensor error.
- Note 6 – SDA not included (separate electrical specification). The device can sink more than 20mA, however total I_{SINK} from all PUPx pins should not exceed 6mA or ADOC_{ACC} specification will be affected
- Note 7 – The formula for the total ADC inaccuracy is: $[(\text{ADC read voltage}) \pm \text{INL}] * (\text{range of gain error}) + \text{range of offset error}$
- Note 8 – When temperature sensor is not used, as determined by the hex file configuration setting, sensor accuracy is tested for typical values only.
- Note 9 – The term “FAULT#” throughout this document describes a pin and output signal, whereas the term “fault” describes an operating condition that may or may not activate the FAULT# pin. The FAULT# pin can only be activated by Ain1, Ain2 and Temperature fault conditions.
- Note 10 – Guaranteed by Design and/or Characterization.
- Note 11 – ADC accuracy can be improved using the following formula: $1024 * \text{Limit(V)}_{\text{NEW}} / (4 * \text{VREF_ADC})$
Where $\text{Limit(V)}_{\text{NEW}} = \text{LIMIT(V)} * (1.00035 + 0.00035 * \text{LIMIT(V)}) - 0.002$. VREF_ADC is the actual device voltage reference to 4 significant digits.
- Note 12 – ADC accuracy can be improved using the following formula: $1024 * \text{Limit(V)}_{\text{NEW}} / (4 * \text{VREF_ADC})$
Where $\text{Limit(V)}_{\text{NEW}} = \text{LIMIT(V)} * (0.99965 + 0.00035 * \text{LIMIT(V)}) - 0.011$. VREF_ADC is the actual device voltage reference to 4 significant digits.

AC OPERATING CHARACTERISTICS

Over recommended operating conditions, unless otherwise noted. All voltages are relative to GND. See Figure 5 and 6 Timing diagrams.

Symbol	Description	Conditions	Min	Typ	Max	Unit
t _{DPON}	Programmable power-on delay from restart timer expiration to PUP _V active	T _{DPON} = 0.64ms	-25	t _{DPON}	+25	%
		T _{DPON} = 12.5ms				
		T _{DPOFF} = 25ms				
		T _{DPOFF} = 50ms				
t _{DPOFF}	Programmable power-off delay from VM _X off to PUP _V inactive	T _{DPOFF} = 0.64ms	-25	t _{DPOFF}	+25	%
		T _{DPOFF} = 12.5ms				
t _{PRTO}	Programmable reset time-out delay	T _{PRTO} = 0.64ms	-25	t _{PRTO}	+25	%
		T _{PRTO} = 25ms				
		T _{PRTO} = 100ms				
		T _{PRTO} = 200ms				
t _{STT}	Programmable sequence termination timer	T _{STT} = OFF	-25	t _{STT}	+25	%
		T _{STT} = 100ms				
		T _{STT} = 200ms				
		T _{STT} = 400ms				
t _{FTRD}	Fault-triggered restart delay	Time from restart timer expiration to PUP _V active after a fault-triggered power-off or force-shutdown.		2.4		s
t _{FTRDACC}	Fault-triggered restart delay accuracy		-25	t _{FTRD}	+25	%
t _{CTRD}	Command-triggered restart delay	Time from restart timer expiration to PUP _V active after command-triggered power-off or force-shutdown.		12.5		ms
t _{CTRDACC}	Command-triggered restart delay accuracy		-25	t _{CTRD}	+25	%
T _{ADC}	10-bit ADC sampling period	Time for ADC conversion of all 11 channels		2		ms
t _{ADC}	10-bit ADC sampling time per channel	Time for one ADC conversion		182		μs
T _{DC_CONTROL}	ADOC sampling period	Update period for ADOC of channels A – F		1.7		ms
t _{DC_CONTROL}	ADOC sampling time per channel	Update time for ADOC per channel		283		μs
t _{MARGIN}	Margin Time from Nominal	Slow Margin, ± 10% change in voltage with 0.1% ripple TRIM_CAP=1μF		850		ms
		Fast Margin, ± 10% change in voltage with 0.1% ripple TRIM_CAP=1μF		85		ms
t _{A-M_SUSPEND}	Auto-Monitor Suspend Period	Auto-Monitor suspended indefinitely by a faulty I ² C transaction	200	300	400	ms

I²C-2 WIRE SERIAL INTERFACE AC OPERATING CHARACTERISTICS –100/400 kHz

T = -40C to +85C, VDD = +2.8V to +5.5V, unless otherwise noted. All voltages are relative to GND.
See Figure 4 Timing Diagram.

Symbol	Description	Conditions	100kHz			400kHz			Units
			Min	Typ	Max	Min	Typ	Max	
f _{SCL}	SCL clock frequency		0		100	0		400	KHz
T _{LOW}	Clock low period		4.7			1.3			μs
T _{HIGH}	Clock high period		4.0			0.6			μs
t _{BUF}	Bus free time	Before new transmission – Note 13	4.7			1.3			μs
t _{SU:STA}	Start condition setup time		4.7			0.6			μs
t _{HD:STA}	Start condition hold time		4.0			0.6			μs
t _{SU:STO}	Stop condition setup time		4.7			0.6			μs
t _{AA}	Clock edge to data valid	SCL low to valid SDA (cycle n)	0.2		3.5	0.2		0.9	μs
t _{DH}	Data output hold time	SCL low (cycle n+1) to SDA change	0.2			0.2			μs
t _R	SCL and SDA rise time	Note 13			1000			1000	ns
t _F	SCL and SDA fall time	Note 13			300			300	ns
t _{SU:DAT}	Data in setup time		250			150			ns
t _{HD:DAT}	Data in hold time		0			0			ns
TI	Noise filter SCL and SDA	Noise suppression		100			100		ns
t _{WR_CONFIG}	Write cycle time config	Configuration registers			10			10	ms
t _{WR_EE}	Write cycle time EE	Memory array			5			5	ms

Note 13 - Guaranteed by Design.

TIMING DIAGRAMS

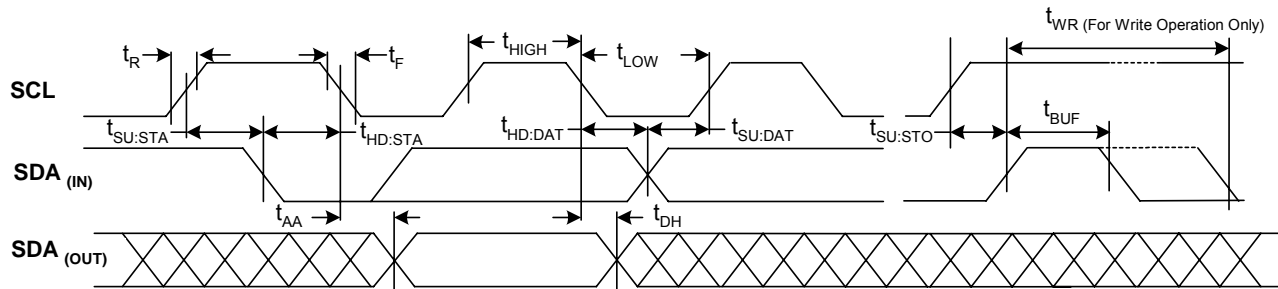

Figure 4 - Basic I²C Serial Interface Timing

TIMING DIAGRAMS (CONTINUED)

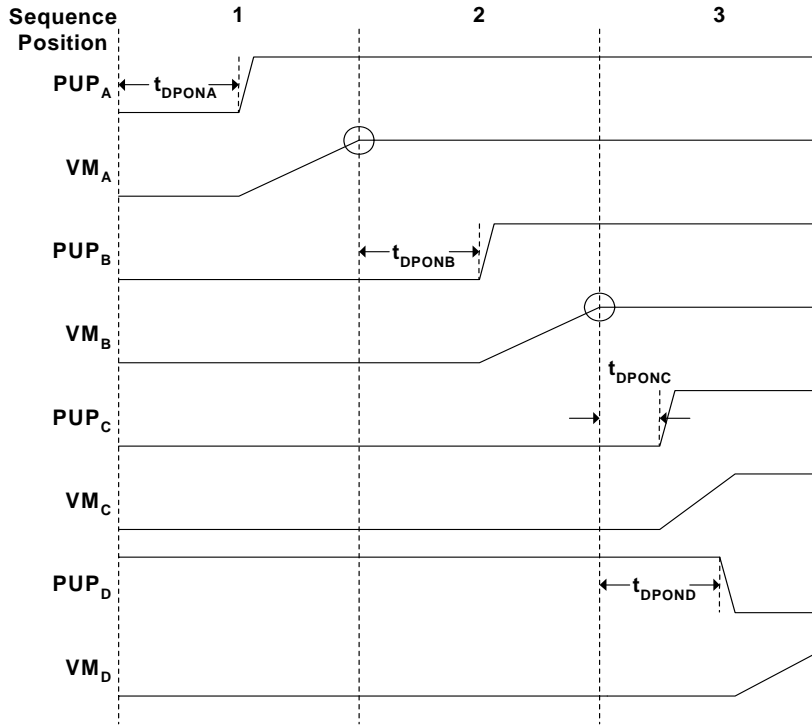

Figure 5 - The SMM766B cascade sequencing the supplies on and then monitoring for fault conditions.

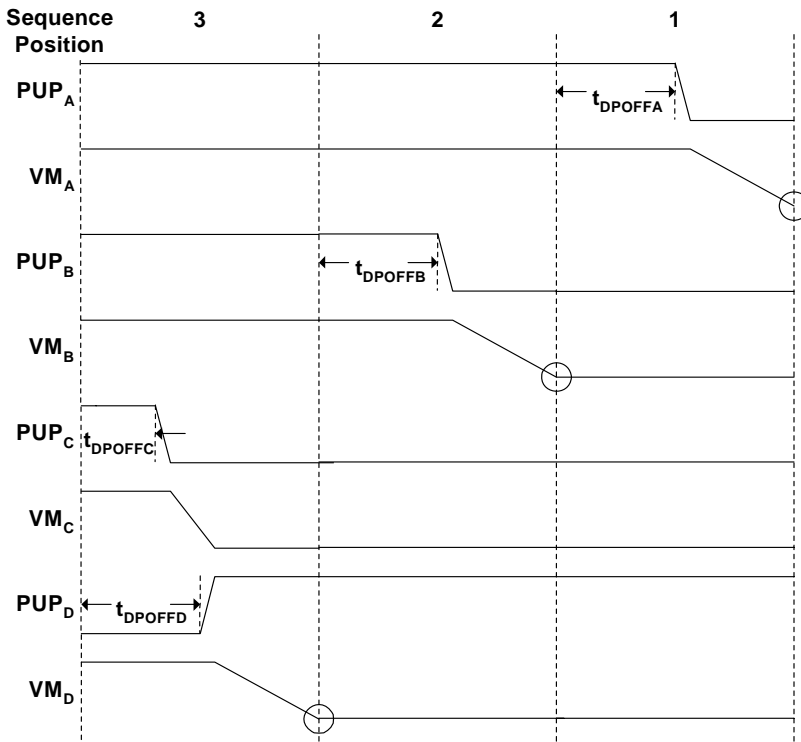

Figure 6 - The SMM766B cascade sequencing the supplies off.

APPLICATIONS INFORMATION

DEVICE OPERATION

POWER SUPPLY

The SMM766B can be powered by either a 12V input through the 12VIN pin or by a 3.3V or 5.0V input through the VDD pin. The 12VIN pin feeds an internal programmable regulator that internally generates either 5.5V or 3.6V. A voltage arbitration circuit allows the device to be powered by the highest voltage from either the regulator output or the VDD input. This voltage arbitration circuit continuously checks for these voltages to determine which will power the SMM766B. The resultant internal power supply rail is connected to the VDD_CAP pin that allows both filtering and hold-up of the internal power supply. To ensure that the input voltage is high enough for reliable operation, an under voltage lockout circuit holds the controlled supplies off until the UVLO thresholds are met. When multiple Sequence-Link™ devices are connected, the same VDD and/or 12VIN supplies must power all devices.

MODES OF OPERATION

The SMM766B has four basic modes of operation (shown in Figures 5 through 8): power-on sequencing mode, ongoing operations-monitoring mode, supply margining mode, and power-off sequencing mode. In addition, there are two features:

ADOC and force-shutdown, which can be used during monitoring and margining mode. A detailed description of each mode and feature follows.

ACTIVE DC OUTPUT CONTROL (ADOC™)

The SMM766B can actively control the DC output voltage of bricks or DC/DC converters that have a trim pin during monitoring and margining mode. The converter may be an off-the shelf compact device, or may be a “roll your own” circuit on the application board. In either case, the SMM766B dramatically improves voltage accuracy (down to 0.2%) by implementing closed-loop ADOC active control. This utilizes the DC-DC’s “trim” pin as shown in Figure 12, or an equivalent output voltage feedback adjustment “VADJ”, “FB”, or “Sense” node in a user’s custom circuit, Figure 13. Each of the TRIM_x pins on the SMM766B is connected to the trim input pins on the power supply converters. A sense line from the channel’s point-of-load connects to the corresponding VM input. The ADOC function cycles through all 6 channels (A-F) every 1.7ms making slight adjustments to the voltage on the associated TRIM_x output pins based on the voltage inputs on the VM_x pins. These voltage adjustments allow the SMM766B to control the output voltage of power supply converters to within ±0.2% when using a ±0.1% external voltage reference.

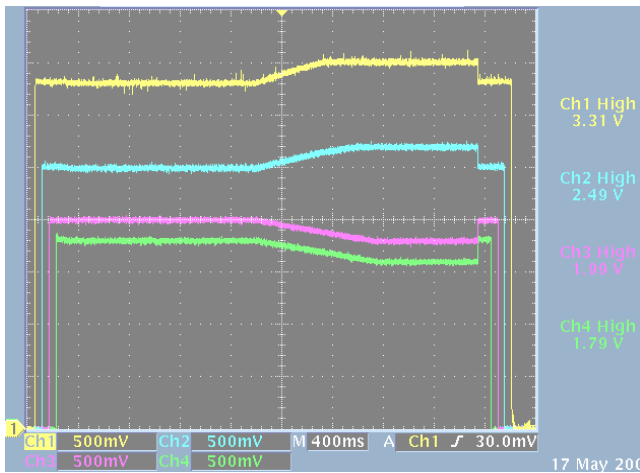

Figure 7 - Waveform shows four SMM766B channels exhibiting Sequence-on to Nominal voltage, Margin High or Low, Nominal voltage and then sequence-off
Ch 1 = 3.3V DC-DC converter output (Yellow trace)
Ch 2 = 2.5V DC-DC converter output (Blue trace)
Ch 3 = 2.0V DC-DC converter output (Purple trace)
Ch 4 = 1.8V DC-DC converter output (Green trace)

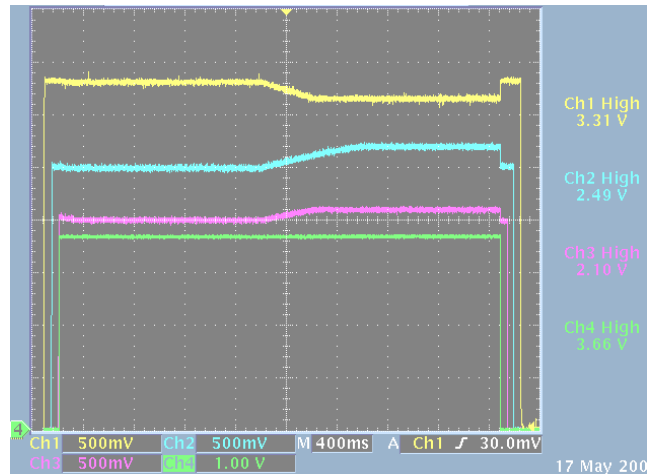

Figure 8 - Waveform shows three SMM766B channels Sequencing-on to Nominal voltage, Margin High and Low, and then sequence-off. Channel 4 shows the HEALTHY signal.
Ch 1 = 3.3V DC-DC converter output (Yellow trace)
Ch 2 = 2.5V DC-DC converter output (Blue trace)
Ch 3 = 2.0V DC-DC converter output (Purple trace)
Ch 4 = Healthy signal output (Green trace)

APPLICATIONS INFORMATION (CONTINUED)

A pulse of current either sourced or sunk for 5 μ s every 1.7ms, to the capacitors connected to the TRIM_CAP_x pins adjusts the voltage output on the TRIM_x pins. The voltages on the TRIM_CAP_x pins are buffered and applied to the TRIM_x pins. The voltage adjustments on the TRIM_x pins cause a slight ripple of less than 1mV on the power supply voltages. The amplitude of this ripple is a function of the TRIM_CAP capacitor and the trim gain of the converter. Application Note 37 details the calculation of the TRIM_CAP capacitor to achieve a desired minimum ripple.

Each channel can be programmed to either enable or disable the ADOC function. When disabled or not active, the TRIM_x pins on the SMM766B are high impedance inputs. If disabled and not used, they can be connected to ground. The voltages on the TRIM_x pins are buffered and applied to the TRIM_CAP_x pins charging the capacitors. This allows a smooth transition from the converter powering up to its nominal voltage, to the SMM766B controlling that voltage, and to the ADOC nominal setting.

The pulse of current can be increased to a 10X pulse of current until the power supply voltages are at their nominal settings by selecting the programmable Fast Margin option. As the name implies, this option decreases the time required to bring a supply voltage from the converter's nominal output voltage to the ADOC nominal, high, or low voltage setting.

Note: The ADC and ADOC functions are not related except that they share VREF. ADC errors will not necessarily show up as ADOC errors and vice versa. ADOC accuracy specs do not imply the same accuracy for the ADC. See individual specs for details.

POWER-ON CASCADE SEQUENCING

The SMM766B can be programmed to sequence on 48 supplies occupying up to 29 sequence positions. This is accomplished using the SEQ_LINK pin. Each of the 6 channels (A-F) on a SMM766B has an associated open drain PUP output that, when connected to a converter's enable pin, controls the turn-on of the converter. The channels are assigned sequence positions to determine the order of the sequence. The polarity of each of the PUP_x outputs is programmable for use with various types of converters.

Power-on sequencing is initiated on the rising edge of the PWR_ON pin. Once the PWR_ON pin is asserted

high, it must remain high until the sequence-on event has completed. Should the PWR_ON pin be low after the last sequence position has exceeded its programmed UV1 limit, and for a period of 25ms afterwards, the SMM766B will perform a sequence-off event. A forced shutdown will also be issued by the SMM766B when the next PWR_ON assertion occurs if the sequence termination timer is enabled. Following the forced shutdown, the SMM766B will latch off if it is programmed for zero retries. If not programmed for zero retries, a power-on sequence will be initiated after 2.4 seconds.

The SMM766B can be programmed to wait until any or all VDD, 12VIN, and Internal Temp (Internal Temperature) ADC readings are within their respective voltage threshold or temperature limits before power-on sequencing is allowed to begin. This ensures that the converters have reached their full supply voltage before they are enabled.

On the rising edge of the PWR_ON pin the SMM766B will wait a power-on delay time (t_{DPON}) for any channels in the first sequence position (position 1) and then activate the PUP_x outputs for those channels. The power-on delay times are individually programmable for each channel. The SMM766B will then wait until all VM_x inputs of the channels assigned to the first sequence position are above their user programmable UV1 thresholds, which is called cascade sequencing.

At this point, the SMM766B will enter the second sequence position (position 2) and begin to timeout the power-on delay times for the associated channels. This process continues until all of the channels assigned to participate in the sequence have turned on and are above their UV1 threshold. Once the sequence has completed the status register indicates that all sequenced power supply channels have turned on. After the sequence has completed the SMM766B will begin the ADOC of the enabled channels. The power-on sequencing mode ends when the ADOC channels are at their nominal voltage setting. The "Ready" bit in the status register signifies that the voltages are at their set points.

The programmable sequence termination timer can be used to protect against a stalled power-on sequence. This timer resets itself at the beginning of each sequence position. All channels in the sequence position must go above their UV1 threshold before the sequence termination timer times out (t_{STT}) or the sequence will terminate by pulling the FS# pin low,

APPLICATIONS INFORMATION (CONTINUED)

initiating a Force Shutdown. The status register contains bits indicating in which sequence position the timer timed out. This sequence termination timer has four settings of OFF, 100ms, 200ms and 400ms. While the SMM766B is in the power-on sequencing mode the RST# output is held active and the HEALTHY output is held inactive regardless of trigger sources (Figure 8). The power-off and force-shutdown trigger options are also disabled while in this mode. Furthermore, the SMM766B will not respond to activity on the PWR_ON pin or to a power-off I²C command during power-on sequencing mode.

The SMM766B permits multiple supplies to occupy the same sequence position. When a sequence position is shared, each channel will be enabled after its respective power-on delay. When the last channel occupying a shared sequence position exceeds its UV1 setting the SMM766B will increment to the next sequence position. Any unused channel should be assigned to the null sequence position.

Note: During the sequence-on event, the SMM766B ignores all limit triggers. Limit trigger monitoring begins after the last sequence position exceeds its UV1 setting when “Limit Triggers Enabled After Sequencing Ready” is selected and after ADOC is complete when “Limit Triggers Enabled After Active Control Ready”.

ONGOING OPERATIONS-MONITORING MODE

During ongoing operations mode, the part can monitor, and actively control via ADOC, and use the force-shutdown operation if necessary.

Once the power-on sequence is complete, depending on the user programmed settings; the SMM766B will either enter the ongoing operations mode directly or wait for ADOC to successfully bring all channels within their nominal values. The ongoing operations mode will end when a power-off sequence, or force-shutdown has been initiated.

Once the ongoing operations mode has begun, the SMM766B continues to monitor all VM_X inputs, the VDD and 12VIN inputs, and two temperature sensor inputs with a 10-bit ADC. Each of these inputs is sampled and converted by the ADC every 2ms. The ADC input has a range of 0V to four times the voltage on VREF for inputs VM_{A-F} and the VDD input. The range is extended to 12 times VREF for the 12VIN input and is reduced to two times VREF for the AIN1, AIN2 inputs.

The SMM766B monitors internal temperature using the 10-bit ADC and the automonitor function. Two under-temperature and two over-temperature

thresholds can be set, each with its own programmable threshold options and consecutive conversion, before trigger counter. Resolution is 0.25 C per bit scaled over the range of -128 C to 127.75 C. The temperature value can be acquired over the I²C bus as a 10-bit signed two's complement value.

The SMM766B compares each resulting ADC conversion with two programmable 10-bit under-voltage limits (UV1, UV2) and two programmable 10-bit over-voltage limits (OV1, OV2) for the corresponding input. A consecutive conversion counter is used to provide filtering of the ADC inputs. Each limit can be programmed to require 1, 2, 4 or 6 consecutive out-of-limit conversions before it is said to be in fault. One in-limit conversion will remove the fault from the threshold limit. This provides digital filtering of the monitored inputs. The ADC inputs VM_{A-F} can use additional filtering by connecting a capacitor from the corresponding CAP_X pin to ground to form an analog RC filter (R=25kΩ). The input is considered to be in a fault condition if any of its limit thresholds are in fault. Setting an OV threshold limit to full-scale (3FF_{HEX}), or setting a UV threshold limit to 000_{HEX}, ensures that the limit can never be in fault. The status registers provide real-time status of all monitored inputs.

The voltage threshold limits for inputs VM_{A-F}, VDD and 12VIN can be programmed to trigger the RST# and HEALTHY outputs as well as a Fault-Triggered force-shutdown and power-off operation when exceeded. The threshold limits for the internal temperature sensor and the AIN1/AIN2 inputs can be programmed to assert RST#, HEALTHY, and FAULT# output pins

The HEALTHY and FAULT# outputs of the SMM766B are active as long as the monitored threshold remains in violation. The RST# output also remains active as long as the monitored threshold remains in violation. However, once the threshold violation goes away, the RST# will remain active for a programmable reset timeout period (t_{PRTO}).

The SMM766B treats Command-Triggered force-shutdown and power-off operations, those caused by I²C commands and assertion of the FS# and PWR_ON pin, differently than those caused by a Fault-Triggered forced-shutdown and power-off conditions, those caused by UV/OV violations or a sequence termination timer expiration. The mode in which either a Forced Shutdown or a power-off occurs effects how or whether the SMM766B will restart, and the number of allowable retries permitted.

APPLICATIONS INFORMATION (CONTINUED)**AUTOMONITOR MODE**

The automonitor mode, responsible for monitoring all voltage thresholds and triggering the programmable options, is paused during an I²C transaction. This is done to allow the I²C interface to access the internal data bus that is used in the automonitor function. Specifically, the automonitor is paused approximately 100ns after the falling edge of SCL during transmission of the R/W bit of a valid slave address. For normal I²C transactions, the automonitor function is resumed following an I²C STOP issued at the end of the transaction or upon the NACK of an invalid slave address. For I²C ADC conversion transactions, which employ acknowledge polling, the automonitor function is resumed after the conversion has completed (appr. 300us after the second ACK of the transaction) and following an I²C STOP issued at the end of the transaction or upon the NACK of an invalid slave address.

During every suspension of the automonitor, a 200msec timer is activated. This timer is reset on every falling edge of SCL. The clock stage will determine the exact timeout period, typically between 200msec and 400msec. Should the I²C transaction fail, this timer will expire and restart the automonitor. Please note that if the timer expires during an I²C transaction, the current I²C transaction is cancelled.

See “Auto-Monitor Function” section for timing details and conditions under which the Automonitor timer will be asserted.

TEMPERATURE SENSOR ACCURACY

The internal temperature sensor accuracy is $\pm 6^{\circ}\text{C}$ from -40 to $+85^{\circ}\text{C}$. The sensor measures the temperature of the SMM766B die and the ambient temperature. If VDD is at 5V, the die temperature is $+2^{\circ}\text{C}$ and at 12V, it is $+4^{\circ}\text{C}$. In order to calculate this difference in specific applications, measure the VDD or 12VIN supply current and calculate the power dissipated and multiply by $80^{\circ}\text{C}/\text{W}$. For instance, 5V and 5mA is 25mW, which creates a 2°C offset.

Note: For hex files (configuration settings) that indicate no use of the temperature sensor, only the typical temperature sensor accuracy is valid.

MARGINING

The SMM766B has two additional ADOC voltage settings for channels A-F, margin high and margin low. The margin high and margin low voltage settings can range from 0.3V to VDD of the converters' nominal output voltage, depending on the specified margin

range of the DC-DC converter. These settings are stored in the configuration registers and are loaded into the ADOC voltage setting by margin commands issued via the I²C bus. The channel must be enabled for ADOC in order to enable margining. The margin command registers contain two bits for each channel that decode the commands to margin high, margin low, or control to the nominal setting. Therefore, any combination of margin high, margin low, and nominal control is allowed in the margining mode.

Once the SMM766B receives the command to margin the supply voltages, it begins adjusting the supply voltages to move toward the desired setting. When all channels are at their voltage setting, a bit is set in the margin status registers.

Note: Configuration writes or reads of registers 00_{HEX} to 0F_{HEX} should not be performed while the SMM766B is margining.

POWER-OFF CASCADE SEQUENCING

The SMM766B performs power-off sequencing in the reverse order of power-on sequencing.

Power-off cascade sequencing can be initiated by the PWR_ON pin, via I²C control or triggered by a fault condition on any of the monitored inputs. Toggling the PWR_ON pin low will initiate the power-off sequence.

To enable software control of the power-off sequencing feature, the SMM766B offers an I²C command to initiate power-off sequencing while the PWR_ON pin is asserted. Furthermore, power-off sequencing can be initiated by a fault condition on a monitored input.

Once power-off sequencing begins, the SMM766B will wait a power-off delay time (t_{DPOFF}) for any channel in the last sequence position and then deactivate the PUP outputs for those channels. The power-off delay times are individually programmable for each channel. The SMM766B will then wait until all VM_x inputs of the channels assigned to that sequence position are below the programmed OFF thresholds.

At this point, the SMM766B will move to the next sequence position and begin to timeout the power-off delay times for the associated channels. This process continues until all of the channels in the sequence have turned off and are below their OFF thresholds.

The status register reveals that all sequenced channels have turned off. The power-off sequencing mode ends when all sequenced supplies are below their OFF thresholds.

APPLICATIONS INFORMATION (CONTINUED)

The sequence termination timer can be used to protect against a stalled power-off sequence. This timer resets itself at the beginning of each sequence position. All channels in the sequence position must go below their OFF threshold before the sequence termination timer times out (t_{STT}) or the sequence will terminate and all PUP outputs will be switched to their inactive state. This timer has four settings of: OFF, 100ms, 200ms and 400ms. The sequence termination timer can be disabled separately for power-off sequencing.

While the SMM766B is in the power-off sequencing mode, the RST# output is held active and the HEALTHY output is held inactive, regardless of trigger sources (Figure 8). The force-shutdown trigger option is also disabled while in this mode. Furthermore, the SMM766B will not respond to activity on the PWR_ON pin during power-off sequencing mode.

FORCE SHUTDOWN

The force-shutdown operation brings all PUP_x outputs to their inactive state. This operation is used for an emergency shutdown when there is not enough time to sequence the supplies off. The force-shutdown operation shuts off all sequenced channels pulls the PWR_ON pin low, and waits for the supply voltages to drop below their respective OFF thresholds before beginning a restart sequence.

A force-shutdown operation can be initiated by any one of four events. The first two methods for initiating a force-shutdown are always enabled. Simply taking the FS# pin low will initiate a force-shutdown operation and maintain it until the pin is brought high again. An I²C force-shutdown command allows the force-shutdown operation to be initiated via software control. This bit is cleared after all sequenced channels have dropped below their OFF voltage threshold.

For restarting the device, the FS command needs to be cleared by writing that bit to a zero. This will clear the command and, if the POWER-ON/OFF pin is not being forced low externally the SMM766B will begin a power-on sequence.

LINKED OPERATION

The SMM766B can be linked to multiple Sequence-Link™ devices to create a seamless multi-channel power manager. With linked operation 8 SMM766B devices in a system can sequence up to 48 supplies within 29 sequence positions. The sequencing in this mode can be interlaced, sequencing a supply from device A, then from device B, then again from device A, etc. This extended sequencing is made possible by the inclusion of a SEQ_LINK pin.

For this mode of operation, the control pins, including SEQ_LINK, PWR_ON, and FS# on each device, must be tied together. In addition, the VDD and 12V supply must also be connected on all linked devices. As a consequence when multiple devices are linked together, they must be powered by the same supply.

RESTART

There are two possible conditions in which a restart sequence may be initiated. The first instance occurs when either the FS# pin is asserted or the PWR_ON pin is pulled low thus initiating a command-triggered restart. The second condition occurs when a user programmable fault triggers a force-shutdown operation or a power-off sequence thus resulting in a fault-triggered restart.

In either case, the SMM766B will wait until all voltages have fallen below their user programmable OFF thresholds, after all channels are off, the PWR_ON pin will continue to be held low for a period of time dependent on the nature of the fault.

When a power-off or force-shutdown condition results from a command-triggered power-off or force-shutdown, the SMM766B will automatically begin the restart procedure. When restart begins an internal timer will begin to timeout for a command-triggered Restart Delay (t_{CTRD}) of 12.5 ms. After this time has expired the PWR_ON pin is released, allowing the power-on sequence to begin.

When a power-off or force-shutdown condition results from a fault-triggered power-off or force-shutdown, the SMM766B may or may not begin the restart procedure (see PROGRAMMABLE RETRIES), if restart begins the internal timer will begin to timeout a fault-triggered Restart Delay (t_{FTRD}) of 2.4 s before the PWR_ON pin is released allowing the power-on Sequence to begin.

If the SMM766B is programmed to wait for VDD, 12VIN, or Internal Temp to be valid (>UV1 and <OV1) before power-on sequencing may commence, then this condition will be checked after the restart timer has expired and the PWR_ON pin has been released.

The conditions that may lead to a Fault-Triggered restart include any channel exceeding its user programmable thresholds (OV or UV), set to trigger either a forced-shutdown or a power-off sequence. In addition, in the event that the sequence termination timer times out before a channel reaches its UV1 or OFF threshold, during sequencing, a Fault-Triggered restart occurs.

APPLICATIONS INFORMATION (CONTINUED)**I²C POWER OFF CONTROL**

Power-on sequencing is only permitted while the PWR_ON pin is active. Once the PWR_ON pin is active and the SMM766B has entered monitoring mode, an I²C command may be issued to commence the power-off sequence. This condition will continue until an I²C “power-off clear” command is issued.

PROGRAMMABLE RETRIES

In the event of a persistent system fault, the SMM766B may be programmed to limit the number of Fault-Triggered restarts it will allow. This programmable setting ensures that the SMM766B will

not enter a hiccup-mode of operation, while still reducing susceptibility to transient fault conditions.

In the event of a Fault-Triggered restart the fault will be registered and internally compared to the maximum number of allowable faults. If this number is exceeded then the fault condition will be latched and the PWR_ON and FS# pins will be pulled low while the RST# output is asserted. This fault condition will remain latched until power is cycled on the SMM766B, at which point the PWR_ON and FS# pins will be released, the number of faults will be reset zero, and the restart sequence will begin. The allowable programmable setting include one, three, and unlimited retries.

APPLICATIONS INFORMATION (CONTINUED)

AUTO-MONITOR FUNCTION

The auto-monitor function is used for monitoring all supplies throughout the power-on and power-off sequencing, force shutdown operation, and monitor

mode. The auto-monitor function is paused during an I²C transaction. This function is re-enabled by several methods as described in the diagrams below.

Pausing Auto-Monitor: I²C Transaction Addressing the SMM766B

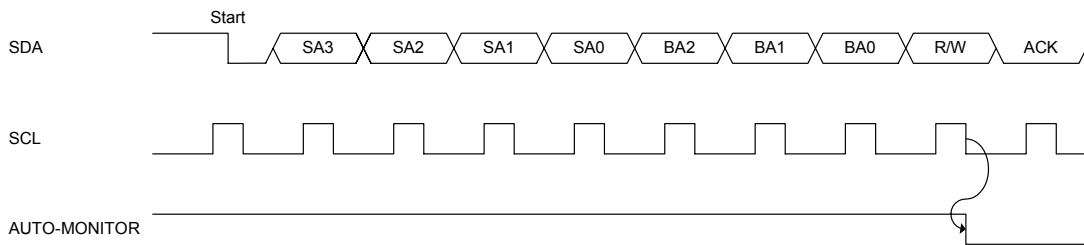

Figure 9A: Auto-monitor is paused on the falling edge of SCL during the R/W bit following a valid slave address.

Re-Enabling Auto-Monitor: I²C Read Transaction

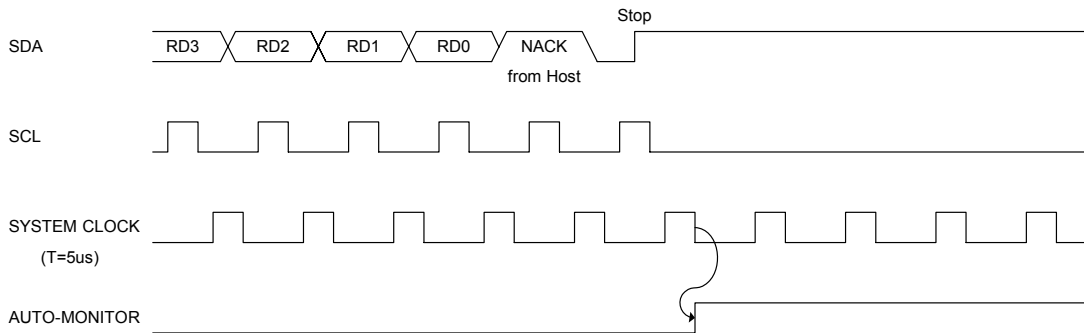

Figure 9B: At the end of an I²C read transaction, auto-monitor is re-enabled on the falling edge of the internal system clock after the Stop.

APPLICATIONS INFORMATION (CONTINUED)

Re-Enabling Auto-Monitor: I²C Command Write Transaction

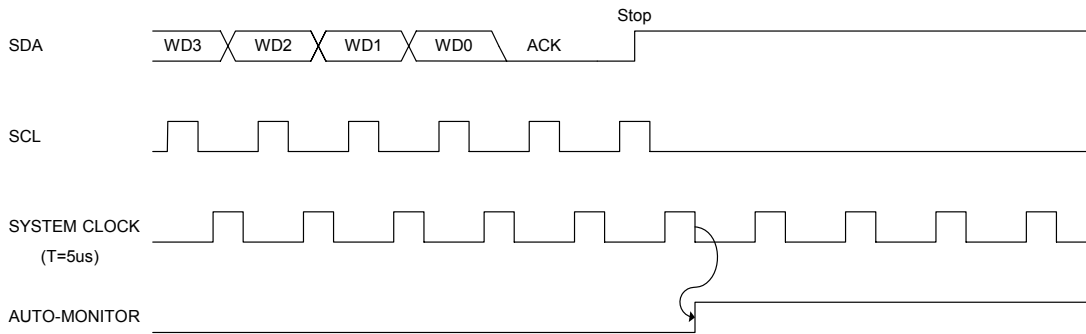

Figure 9C: At the end of an I²C command write transaction, auto-monitor is re-enabled on the falling edge of the internal system clock after the Stop. The I²C command write is any write to slave address 9Xh, word address 8Xh.

Re-Enabling Auto-Monitor: I²C Writes to Configuration, General Purpose Memory and Margin Control Registers

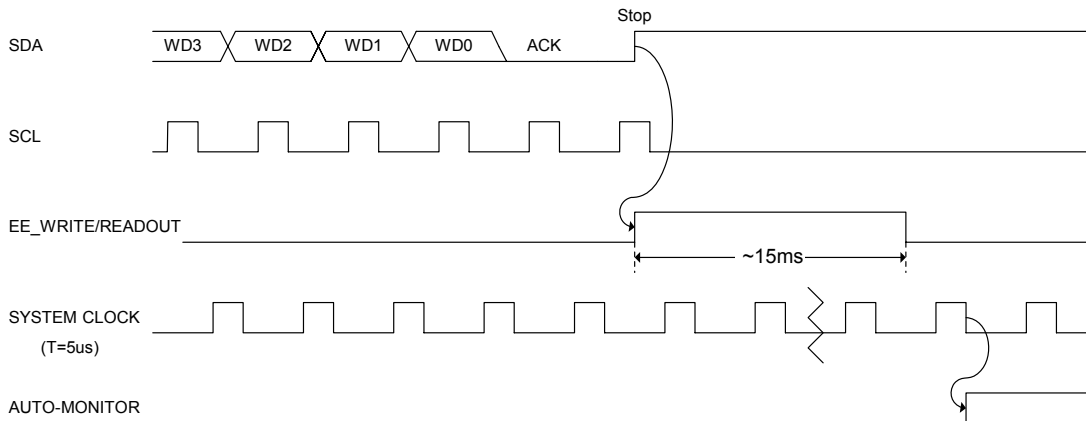

Figure 9D: At the end of an I²C write to configuration, general purpose memory or margin control registers, auto-monitor is re-enabled on the falling edge of the internal system clock after the EE_WRITE/READOUT has completed.

APPLICATIONS INFORMATION (CONTINUED)

Re-Enabling Auto-Monitor: Auto-Monitor Timeout

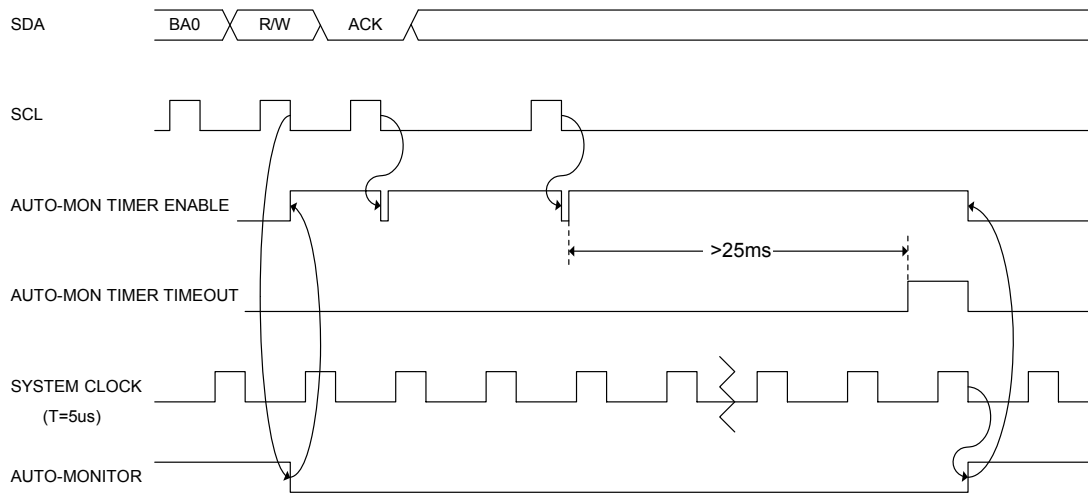

Figure 9E: Auto-monitor is re-enabled on the falling edge of the internal system clock after the auto-monitor timer has timed out. The auto-monitor timer is enabled when auto-monitor is paused and is restarted on the falling edge of SCL.

APPLICATIONS INFORMATION (CONTINUED)

Re-Enabling Auto-Monitor: Invalid Slave Address

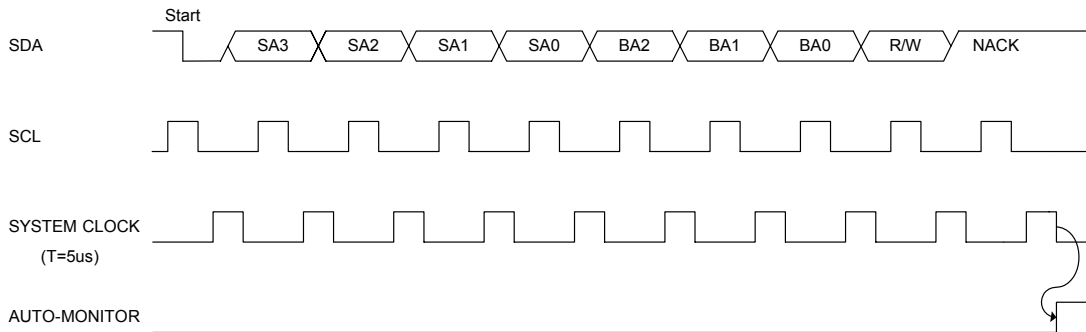

Figure 9F: Auto-monitor is re-enabled on the falling edge of the internal system clock after the falling edge of SCL during the NACK following an invalid slave address.

**Re-Enabling Auto-Monitor: Invalid Slave Address
 During an I²C A-to-D Conversion**

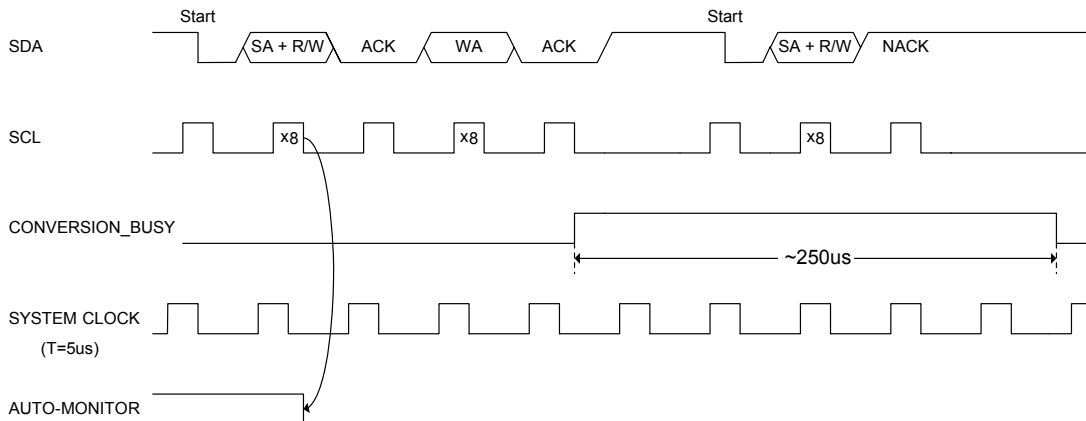

Figure 9G: During the 250us A-to-D conversion time, the activity on SDA and SCL are ignored.

APPLICATIONS INFORMATION (CONTINUED)

Re-Enabling Auto-Monitor: Invalid Slave Address During an I²C A-to-D Conversion

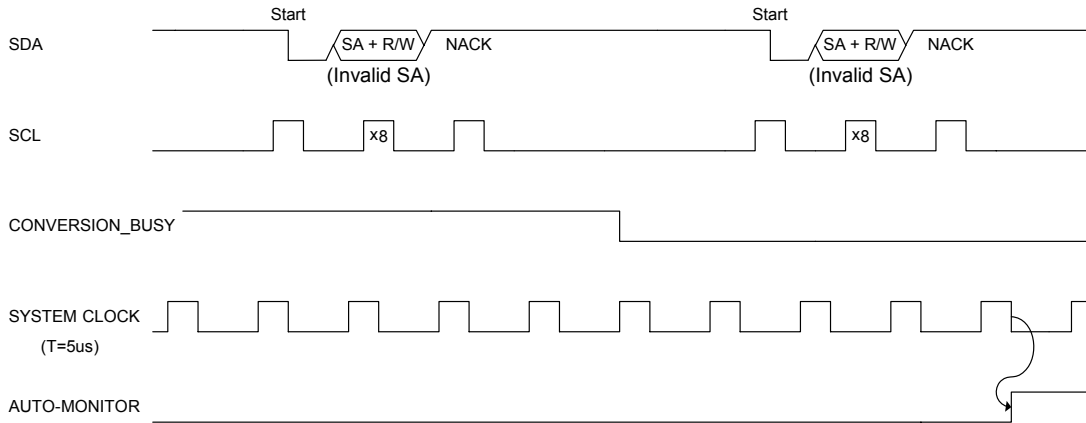

Figure 9H: Auto-monitor is re-enabled on the falling edge of the internal system clock after the falling edge of SCL during the NACK following a invalid slave address after the conversion has completed.

APPLICATIONS INFORMATION (CONTINUED)

UNDERVOLTAGE LOCKOUT

The internally filtered supply voltage as seen across VDD_CAP is edge-triggered to lock out false or nuisance signals during both the power-on and power-

off sequences. If the VDD_CAP voltage falls below 2.5V (Figure 10), an internal undervoltage lockout (UVLO) circuit will reset all internal logic. Once power has recovered above 2.6V the SMM766B will restart as if a Command-Triggered power-off had been issued.

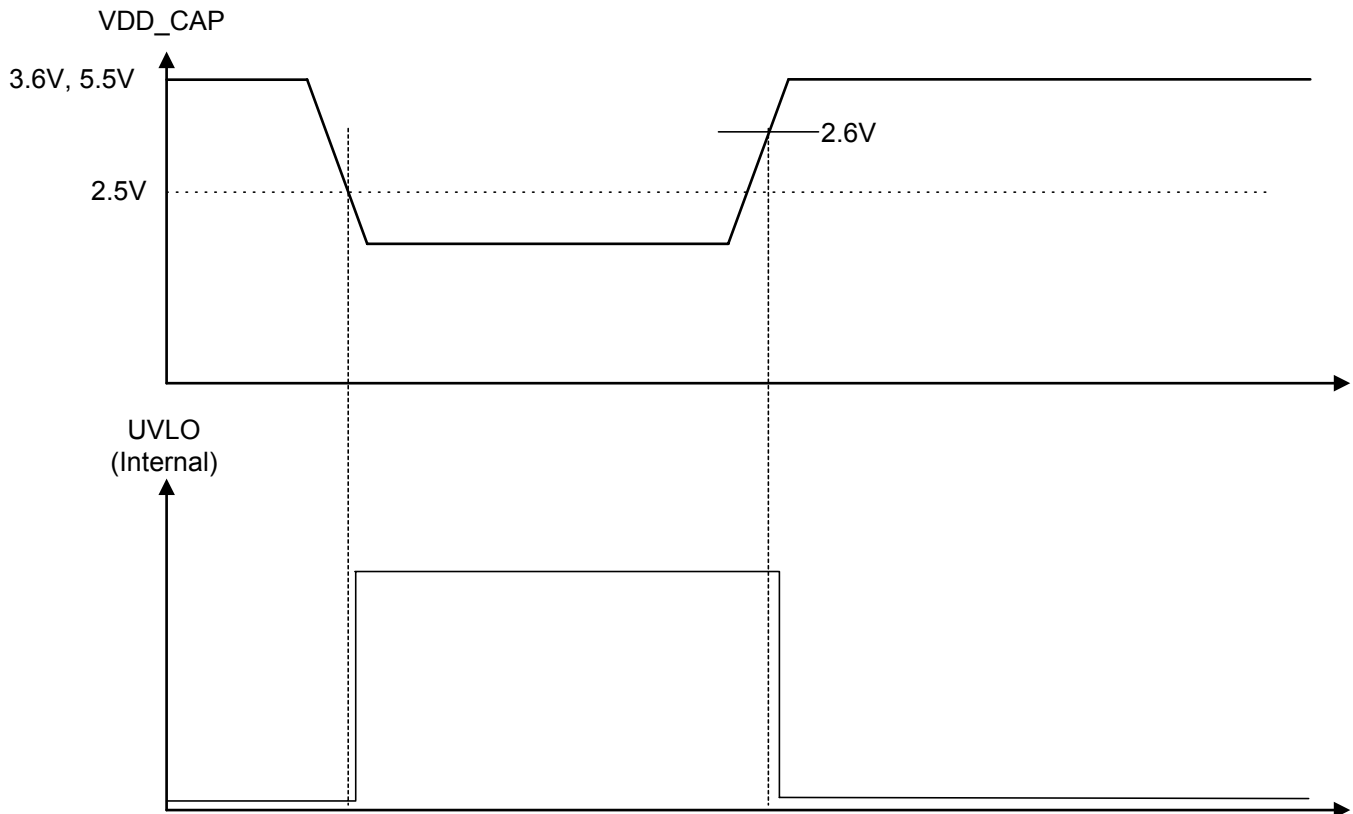

Figure 10 - Timing Sequence recovering from a VDD_CAP Power 'Brown-Out'

APPLICATIONS INFORMATION (CONTINUED)

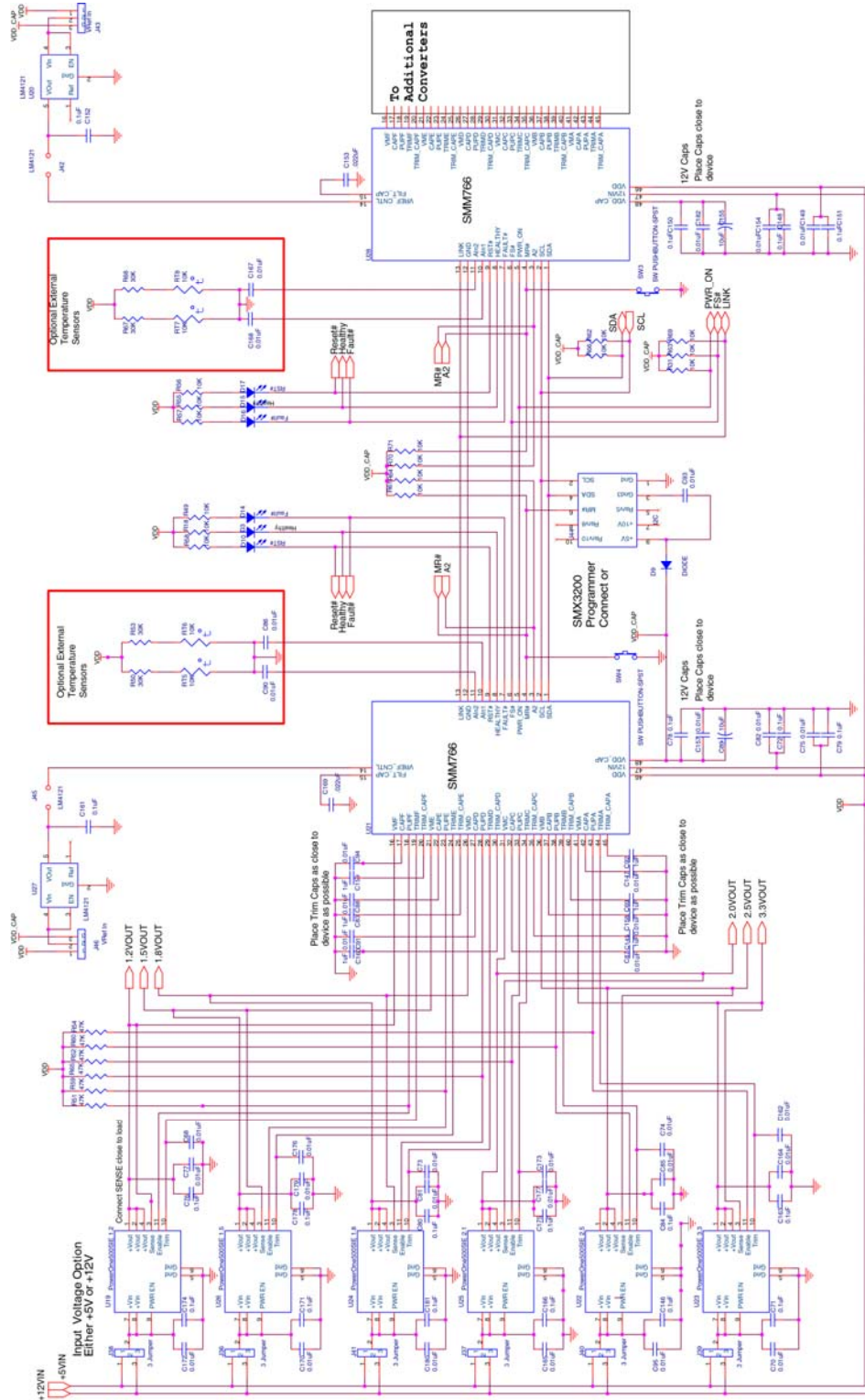

Figure 11 – SMM766B Distributed power applications schematic. The accuracy of the external reference (U10) sets the accuracy of the ADOC function. Total accuracy with a ±0.1% external reference is ±0.2%

DEVELOPMENT HARDWARE & SOFTWARE

The end user can obtain the Summit SMX3200 programming system for device prototype development. The SMX3200 system consists of a programming Dongle, cable and Windows™ GUI software. It can be ordered on the website or from a local representative.

The SMX3200 programming Dongle/cable interfaces directly between a PC's parallel port and the target application. The device is then configured on-screen via an intuitive graphical user interface employing drop-down menus.

The Windows GUI software will generate the data and send it in I²C serial bus format so that it can be directly downloaded to the SMM766B via the programming Dongle and cable. An example of the connection interface is shown in Figure 15.

When design prototyping is complete, the software can generate a HEX data file that should be transmitted to Summit for approval. Summit will then assign a unique customer ID to the HEX code and program production devices before the final electrical test operations. This will ensure proper device operation in the end application.

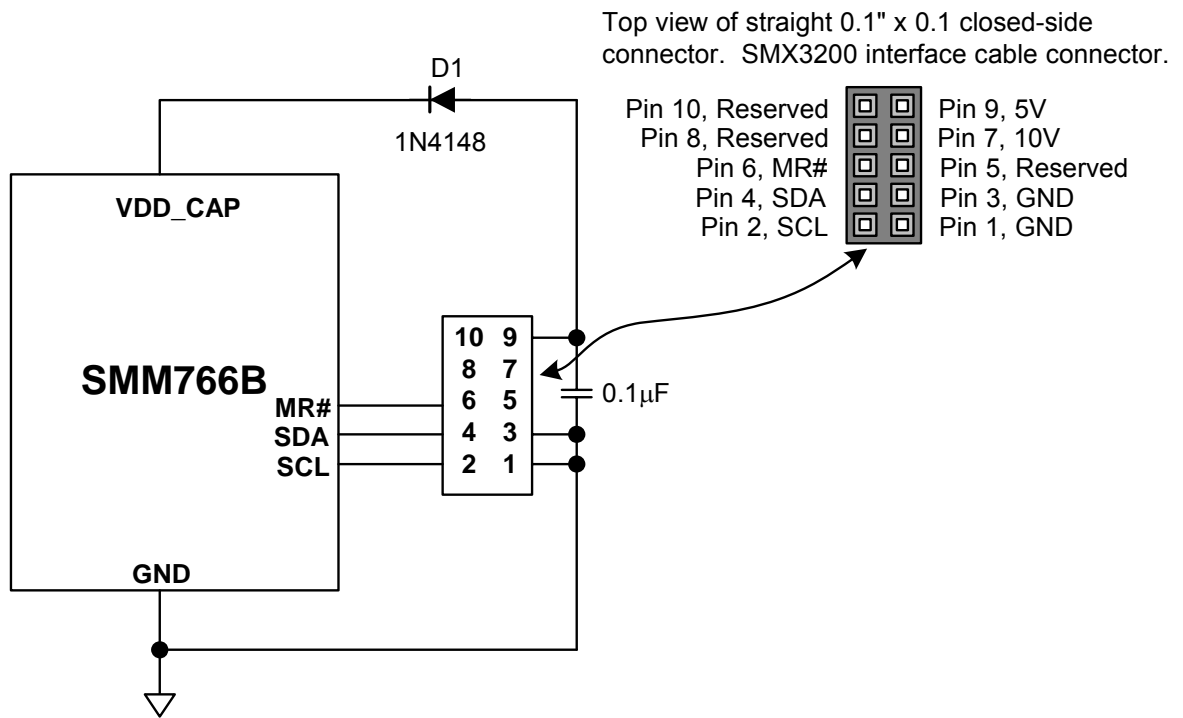

Figure 12 – SMX3200 Programmer I²C serial bus connections to program the SMM766B. Note that the MR# pin does not need to be connected to pin 6 for programming purposes.

The latest revisions of all software and an application brief describing the SMX3200 is available from the website at: http://www.summitmicro.com/tech_support/program_kit/SMX3200.htm

I²C PROGRAMMING INFORMATION

SERIAL INTERFACE

Access to the configuration registers, general-purpose memory and command and status registers is carried out over an industry standard 2-wire serial interface (I²C). SDA is a bi-directional data line and SCL is a clock input. Data is clocked in on the rising edge of SCL and clocked out on the falling edge of SCL. All data transfers begin with the MSB. During data transfers SDA must remain stable while SCL is high. Data is transferred in 8-bit packets with an intervening clock period in which an Acknowledge is provided by the device receiving data. The SCL high period (t_{HIGH}) is used for generating Start and Stop conditions that precede and end most transactions on the serial bus. A high-to-low transition of SDA while SCL is high is considered a Start condition while a low-to-high transition of SDA while SCL is high is considered a Stop condition.

The interface protocol allows operation of multiple devices and types of devices on a single bus through unique device addressing. The address byte is comprised of a 4-bit device type identifier SA[3:0] (slave address) and a 3-bit bus address BA[2:0]. The remaining bit indicates either a read or a write operation. Refer to Table 1 for a description of the address bytes used by the SMM766B.

The device type identifier for the memory array is generally set to 1010_{BIN} following the industry standard for a typical nonvolatile memory. There is an option to change the identifier to 1011_{BIN} allowing it to be used on a bus that may be occupied by other memory devices. The configuration registers are grouped with the memory array and thus use 1010_{BIN} or 1011_{BIN} as the device type identifier. The command and status registers as well as the 10-bit ADC are accessible with the separate device type identifier of 1001_{BIN}.

The bus address bits BA[1:0] are programmed into the configuration registers. Bus address bit BA[2] can be programmed as either 0 or biased by the A2 pin. The bus address accessed in the address byte of the serial data stream must match the setting in the SMM766B and on the A2 pin.

Any access to the SMM766B on the I²C bus will temporarily halt the monitoring function. This does not affect the ADOC function, which will continue functioning and control the DC outputs. This is true not only during the monitor mode, but also during power-on and power-off sequencing when the device is monitoring the channels to determine if they have turned on or turned off.

The SMM766B halts the monitor function from when it acknowledges the address byte until a valid stop is received.

WRITE

Writing to the memory or a configuration register is illustrated in Figures 13, 14, 15, 17 and 19. A Start condition followed by the address byte is provided by the host; the SMM766B responds with an Acknowledge; the host then responds by sending the memory address pointer or configuration register address pointer; the SMM766B responds with an acknowledge; the host then clocks in on byte of data. For memory and configuration register writes, up to 15 additional bytes of data can be clocked in by the host to write to consecutive addresses within the same page. After the last byte is clocked in and the host receives an Acknowledge, a Stop condition must be issued to initiate the nonvolatile write operation.

READ

The address pointer for the configuration registers, memory, command and status registers and ADC registers must be set before data can be read from the SMM766B. This is accomplished by issuing a dummy write command, which is simply a write command that is not followed by a Stop condition. The dummy write command sets the address from which data is read. After the dummy write command is issued, a Start command followed by the address byte is sent from the host. The host then waits for an Acknowledge and then begins clocking data out of the slave device. The first byte read is data from the address pointer set during the dummy write command. Additional bytes can be clocked out of consecutive addresses with the host providing an Acknowledge after each byte. After the data is read from the desired registers, the read operation is terminated by the host holding SDA high during the Acknowledge clock cycle and then issuing a Stop condition. Refer to Figures 16, 18 and 21 for an illustration of the read sequence.

I²C PROGRAMMING INFORMATION (CONTINUED)

WRITE PROTECTION

The SMM766B powers up into a write protected mode. Writing a code to the volatile write protection register can disable the write protection. The write protection register is located at address 87_{HEX} of slave address 1001_{BIN}.

Writing 0101_{BIN} to bits [7:4] of the write protection register allow writes to the general-purpose memory while writing 0101_{BIN} to bits [3:0] allow writes to the configuration registers. The write protection can re-enable by writing other codes (not 0101_{BIN}) to the write protection register. Writing to the write protection register is shown in Figure 13.

CONFIGURATION REGISTERS

The majority of the configuration registers are grouped with the general-purpose memory located at either slave address 1010_{BIN} or 1011_{BIN}. Bus address bits BA[2:1] are programmable. The bus address bit BA[0], however, is used to differentiate the general-purpose memory from the configuration registers and should be set to 1_{BIN} when accessing the configuration registers. Bus address bit BA[2] can be programmed as a “virtual 0” or biased by the A2 pin.

An additional configuration register is located at address 84_{HEX} of slave address 1001_{BIN}.

Writing and reading the configuration registers is shown in Figures 14, 15, 16, 17, and 18

Note: Configuration writes or reads of registers 00_{HEX} to 0F_{HEX} should not be performed while the SMM766B is margining.

GENERAL-PURPOSE MEMORY

The 2k-bit general-purpose memory is located at either slave address 1010_{BIN} or 1011_{BIN}. Bus address bits BA[2:1] are programmable. The bus address bit BA[0], however, is used to differentiate the general-purpose memory from the configuration registers and should be set to 0_{BIN} when accessing general purpose memory. Bus address bit BA[2] can be programmed as a “virtual 0” or biased by the A2 pin.

The word address must be set each time the memory is accessed. Memory writes and reads are shown in Figures 19, 20 and 21.

COMMAND AND STATUS REGISTERS

The command and status registers are located at slave address 1001_{BIN}. Writes and reads of the command and status registers are shown in Figures 22 and 23.

ADC CONVERSIONS

An ADC conversion on any monitored channel can be performed and read over the I²C bus using the ADC read command. The ADC read command, shown in Figure 24, starts with a dummy write to the 1001_{BIN} slave address. Bits [6:3] of the word address byte are used to address the desired monitored input. Once the device acknowledges the channel address, it begins the ADC conversion of the addressed input. This conversion requires 182μs to complete. During this conversion time, acknowledge polling can be used. The SMM766B will not acknowledge the address bytes until the conversion is complete. When the conversion has completed, the SMM766B will acknowledge the address byte and return the 10-bit conversion along with a 4-bit channel address echo.

GRAPHICAL USER INTERFACE (GUI)

Device configuration utilizing the Windows based SMM766B graphical user interface (GUI) is highly recommended. The software is available from the Summit website at:

http://www.summitmicro.com/tech_support/tech.htm#GUI.

Using the GUI in conjunction with this datasheet simplifies the process of device prototyping and the interaction of the various functional blocks. A programming Dongle (SMX3200) is available from Summit to communicate with the SMM766B. The Dongle connects directly to the parallel port of a PC and programs the device through a cable using the I²C bus protocol.

Slave Address	Bus Address	Register Type
1001 _{BIN}	BA2 BA1 BA0	Write Protection Register, Command and Status Registers, One Configuration Register, ADC Conversion Readout
1010 _{BIN} or 1011 _{BIN}	BA2 BA1 0	2-k Bits of General-Purpose Memory
	BA2 BA1 1	Configuration Registers

Table 1 - Address bytes used by the SMM766B.

I²C PROGRAMMING INFORMATION (CONTINUED)

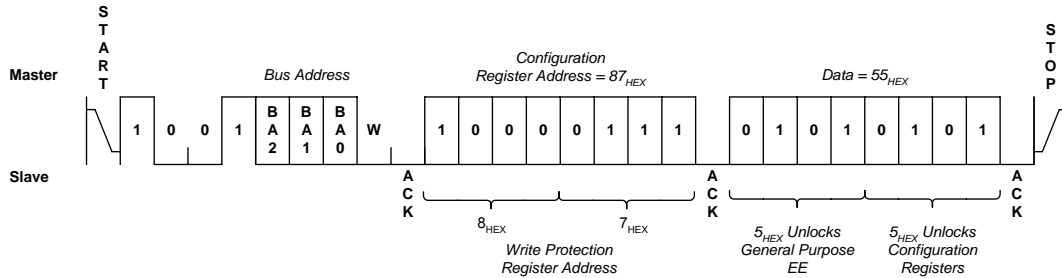

Figure 13 – Write Protection Register Write

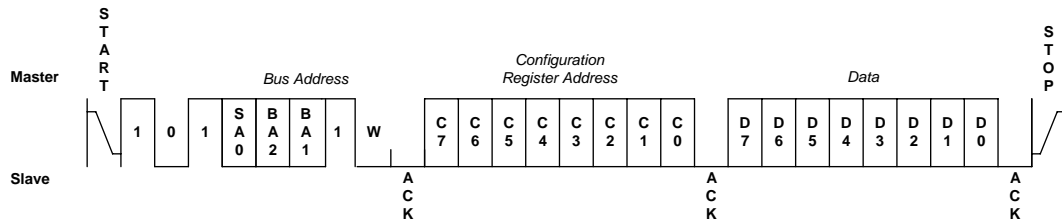

Figure 14 – Configuration Register Byte Write

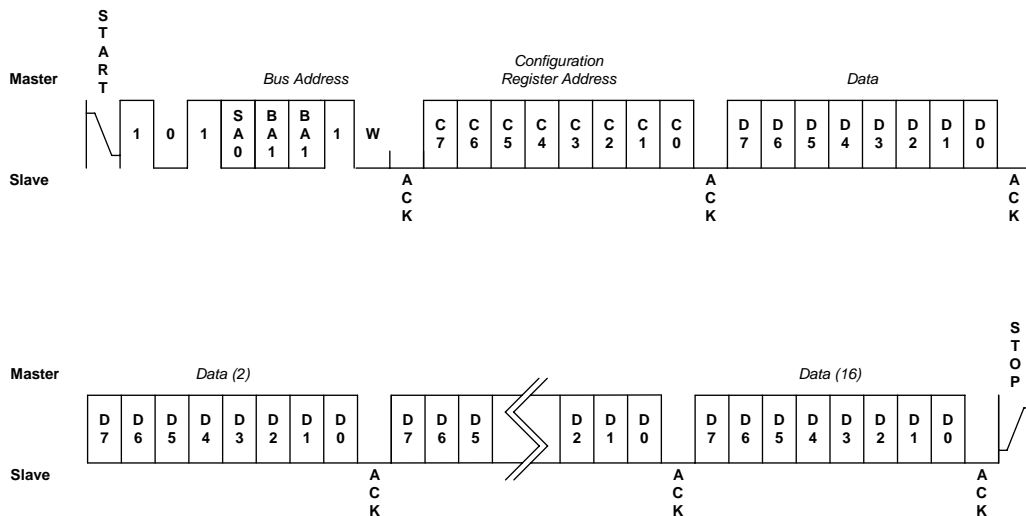

Figure 15 – Configuration Register Page Write

I²C PROGRAMMING INFORMATION (CONTINUED)

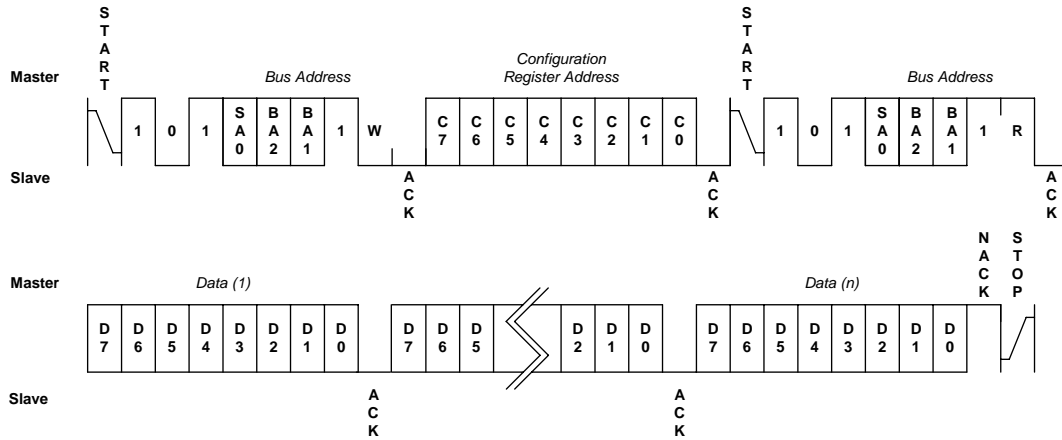

Figure 16 - Configuration Register Read

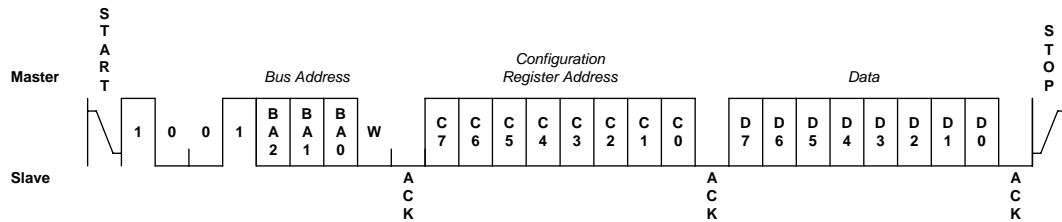

Figure 17 - Configuration Register with Slave Address 1001_{BIN} Write

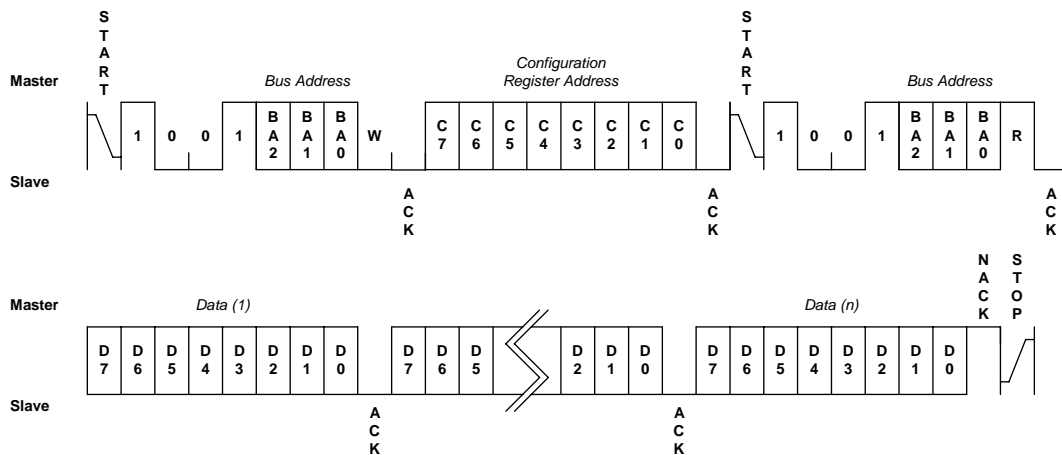

Figure 18 - Configuration Register with Slave Address 1001_{BIN} Read

I²C PROGRAMMING INFORMATION (CONTINUED)

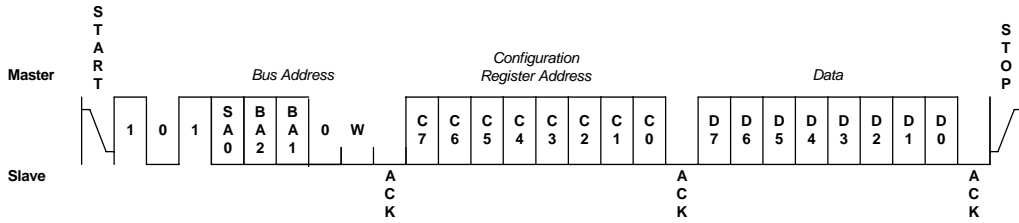

Figure 19 – General Purpose Memory Byte Write

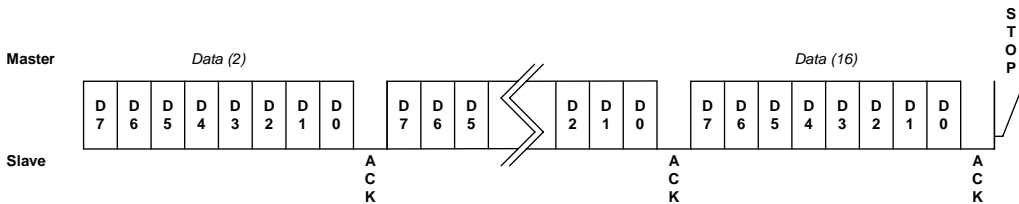
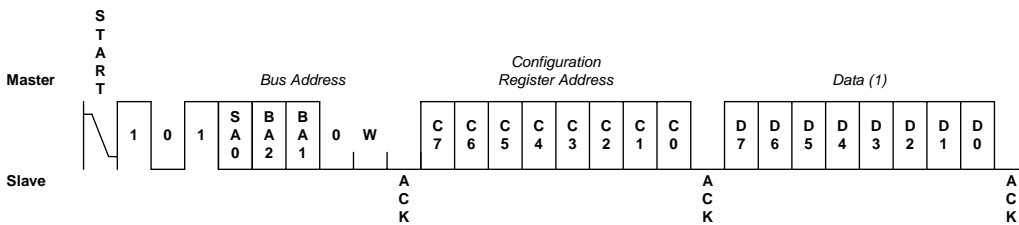

Figure 20 - General Purpose Memory Page Write

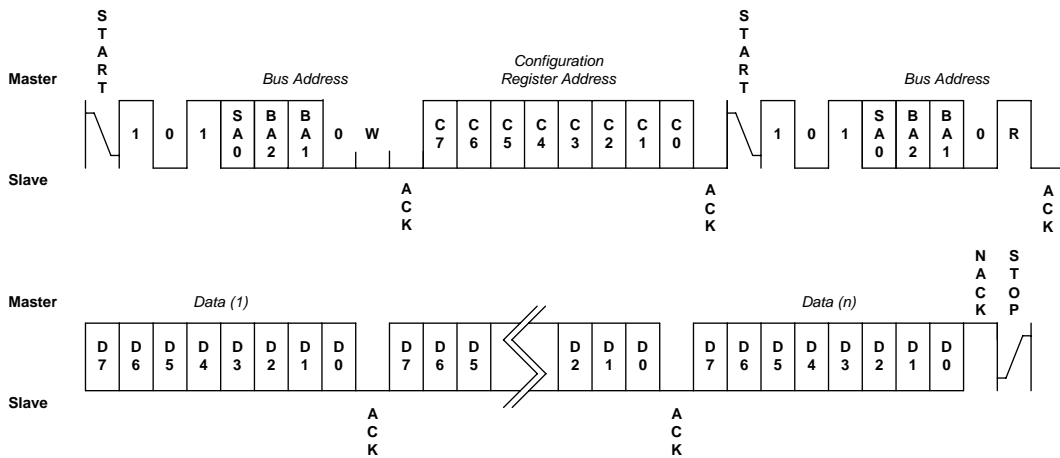

Figure 21 - General Purpose Memory Read

I²C PROGRAMMING INFORMATION (CONTINUED)

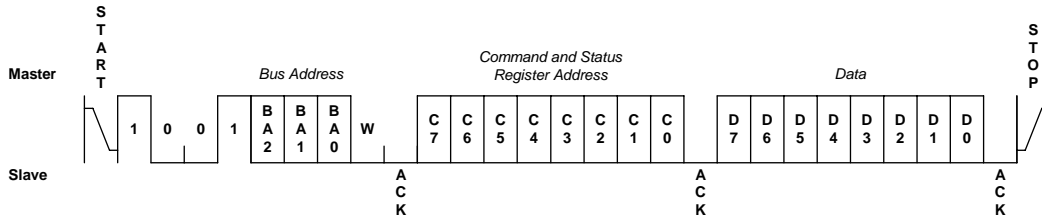

Figure 22 – Command and Status Register Write

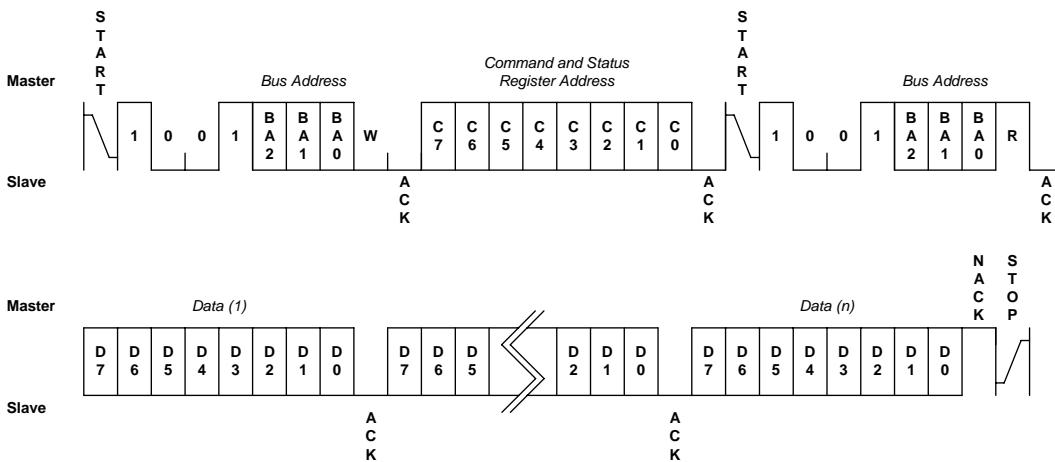

Figure 23 - Command and Status Register Read

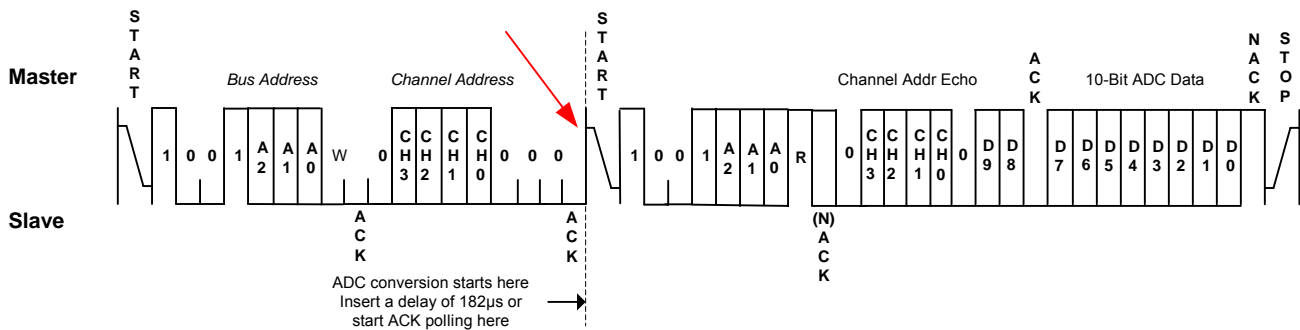

Figure 24 – ADC Conversion Read

Note: It is forbidden to issue an I²C “STOP” command after the write phase of the ADC conversion-read (as shown by the RED arrow in Figure 24). An improper “STOP” command would invalidate the ADC read resulting in erroneous data.

DEFAULT CONFIGURATION REGISTER SETTINGS – SMM766BFC-752

Register	Contents	Register	Contents	Register	Contents	Register	Contents
R0	FD	R40	FD	R96	11	RBD	E0
R1	84	R41	9D	R97	EC	RBE	03
R2	0E	R42	0E	R98	49	RBF	E0
R3	00	R43	2D	R99	85	RC0	03
R4	0E	R44	0E	R9A	81	RC1	38
R5	62	R45	A2	R9B	71	RC2	03
R6	0E	R46	0F	R9C	29	RC3	38
R7	C7	R47	20	R9D	9A	RC4	01
R8	0F	R48	0F	R9E	11	RC5	90
R9	55	R49	B4	R9F	AE	RC6	01
RA	0B	R4A	0B	RA0	49	RC7	90
RB	20	R4B	69	RA1	0A	RC8	00
RC	FF	R4C	00	RA2	80	RC9	00
RD	00	R4D	12	RA3	F6	RCA	00
RE	04	R4E	50	RA4	29	RCB	00
RF	08	R80	4A	RA5	5C	RCC	03
R10	7F	R81	7B	RA6	11	RCD	FF
R11	7F	R82	82	RA7	71	RCE	03
R12	7F	R83	66	RA8	48	RCF	FF
R13	7F	R84	2A	RA9	CD	RD0	00
R14	7F	R85	CD	RAA	80	RD1	00
R15	7F	R86	12	RAB	B8	RD2	00
R30	7F	R87	E1	RAC	29	RD3	00
R31	6E	R88	49	RAD	1F	RD4	03
R32	0E	R89	D7	RB0	11	RD7	D8
R33	DA	R8A	81	RB1	33	RE0	00
R34	0E	R8B	C3	RB2	02	RE1	3D
R35	46	R8C	2A	RB3	52	RE2	00
R36	0E	R8D	29	RB4	03	RE3	3D
R37	80	R8E	12	RB5	FF	RE4	00
R38	0F	R8F	3D	RB6	03	RE5	3D
R39	08	R90	49	RB7	FF	RE6	00
R3A	0F	R91	85	RB8	02	RE7	3D
R3B	D9	R92	81	RB9	23	RE8	00
R3C	00	R93	71	RBA	02	RE9	3D
R3D	12	R94	29	RBB	23	REA	00
R3E	50	R95	D7	RBC	03	REB	3D

The default device ordering number is SMM766BFC-752. It is programmed with the register contents as shown above and tested over the commercial temperature range with a VREF setting of 1.25V. Other standard external VREF voltage settings that can be specified and tested are values of: 1.024, 1.225, 1.250, 2.048, 2.500, 3.000 or 3.300. The value is derived from the customer supplied hex file. New device suffix numbers are assigned to non-default requirements. If other VREF values are required, please contact a Summit Microelectronics Sales Representative.

PACKAGE

48 PIN TQFP PACKAGE

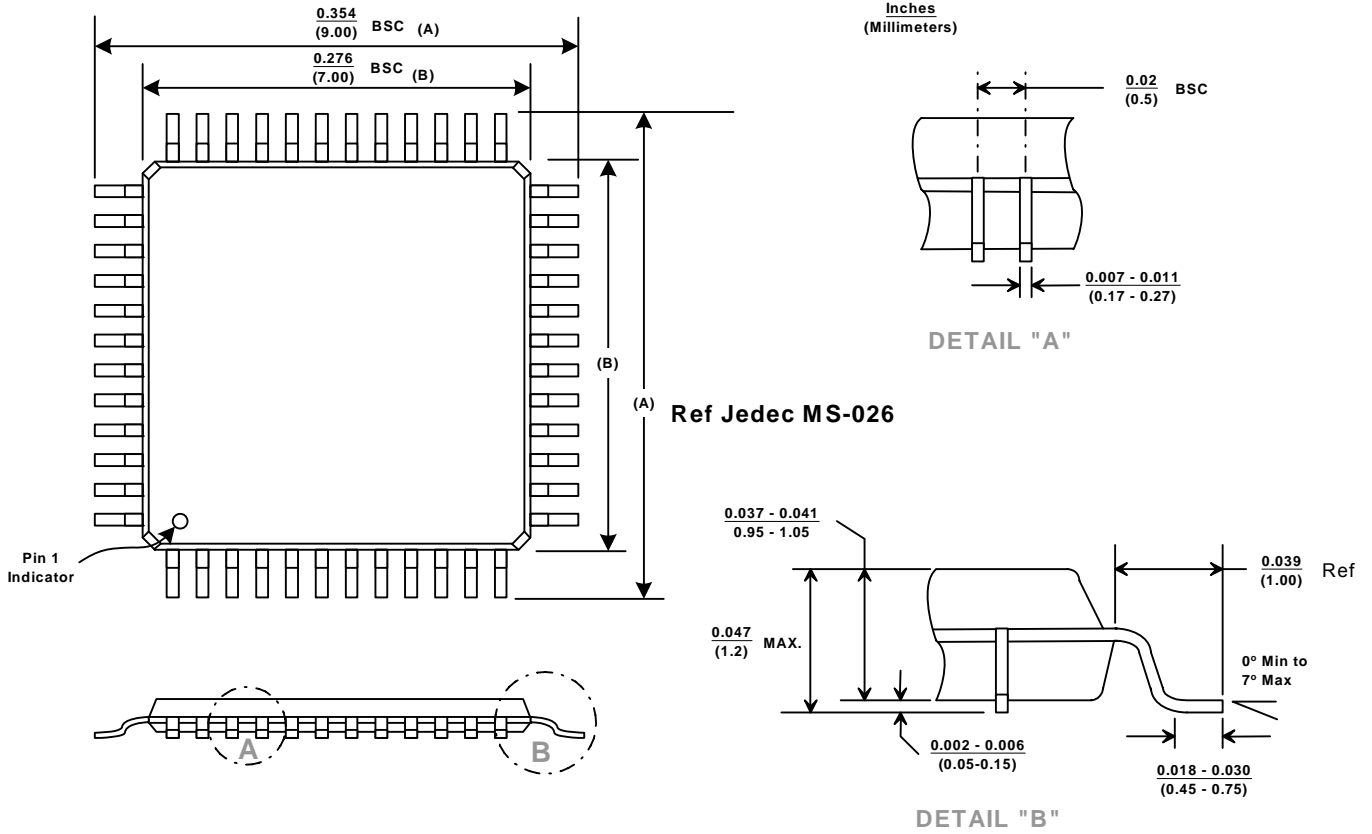

PART MARKING

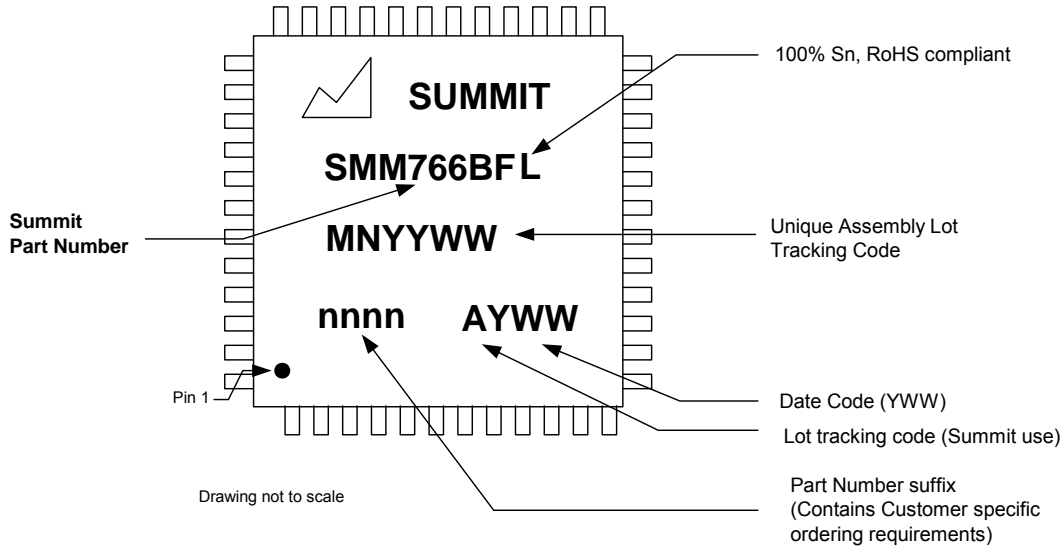

ORDERING INFORMATION

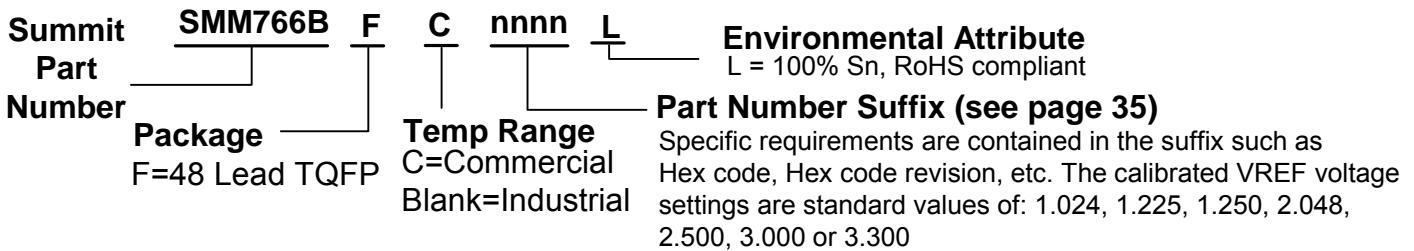

Terms and Definitions

Fault-Triggered	This term refers to either a power-off or force-shutdown operation. When a UV, OV, or sequence termination condition trigger a power-off or force-shutdown a fault triggered power-off or force-shutdown is said to occur. This sets the restart delay at 2.4s, and can limit the number of allowable retries. This term has no correlation to the FAULT pin.
Command-Triggered	This term refers to either a power-off or force-shutdown operation. When either the FS# or PWR_ON pin is asserted or an I2C command is issued a Command-Triggered power-off or force-shutdown is said to occur. This sets the restart delay at 12.5ms, and will not limit the number of allowable retries.
ADOC™	ADOC (Active DC Output Control) is a proprietary secondary closed loop compensation control, used to maintain output voltages to $\pm 0.2\%$.
Power-off	Power-off sequencing refers to cascaded power-off sequencing unless explicitly noted. Cascaded power-off sequencing refers to a feedback based supply termination in which each channel in the previous sequence position is monitored, and the monitored voltage must fall below a programmable OFF threshold before the next sequence position is allowed to turn off. Channels in the same sequence position are not capable of Cascaded power-off sequencing.
Power-on	Power-off sequencing refers to cascaded power-off sequencing unless explicitly noted. Cascaded power-off sequencing refers to a feedback based supply termination in which each channel in the previous sequence position is monitored, and the monitored voltage must fall below a programmable OFF threshold before the next sequence position is allowed to turn off. Channels in the same sequence position are not capable of Cascaded power-off sequencing.
Force-shutdown	When all supplies are immediately disabled without regard to sequence position.
Sequence-Link™	When more than one SMM766B or SMM766B derivatives are connected creating a seamless multi-channel network.
UV	Programmed Under Voltage threshold for monitored channels and supplies
OV	Programmed Over Voltage threshold for monitored channels and supplies
UVLO	Undervoltage Lockout. Prevents voltage at VDD or 12VIN pin from powering the SMM766B until proper operating voltages have been reached.
Margin	The ability to change the nominal output voltage by use of trim pin.
ADC	Analog to Digital Converter. Converts analog voltage to digital voltage. SMM766B represents all measured voltages by 10-bit digital reading.
Retries	The number of times the SMM766B will restart after a Fault-Triggered power-off or force-shutdown.
Restart	When the SMM766B begins power on sequencing, includes initial power-on sequence.
Power-on delay	Delay from restart timer expiration to PUP _Y pin active
Power-off delay	Programmable delay from VM _X off to PUP _Y inactive
Sequence Termination	When a supply fails to reach its programmed UV, or OFF, threshold before expiration of internal timer.
Monitoring	When any quantity including temperature, and voltage is converted to a digital value by the ADC and compared against a user programmable setting.
GUI	Graphical user interface. Program that reads from and writes to non-volatile registers on the SMM766B and displays results in accordance to register function.

NOTICE

Revision 3.1 - This document supersedes all previous versions.

SUMMIT Microelectronics, Inc. reserves the right to make changes to the products contained in this publication in order to improve design, performance or reliability. SUMMIT Microelectronics, Inc. assumes no responsibility for the use of any circuits described herein, conveys no license under any patent or other right, and makes no representation that the circuits are free of patent infringement. Charts and schedules contained herein reflect representative operating parameters, and may vary depending upon a user's specific application. While the information in this publication has been carefully checked, SUMMIT Microelectronics, Inc. shall not be liable for any damages arising as a result of any error or omission.

SUMMIT Microelectronics, Inc. does not recommend the use of any of its products in life support or aviation applications where the failure or malfunction of the product can reasonably be expected to cause any failure of either system or to significantly affect their safety or effectiveness. Products are not authorized for use in such applications unless SUMMIT Microelectronics, Inc. receives written assurances, to its satisfaction, that: (a) the risk of injury or damage has been minimized; (b) the user assumes all such risks; and (c) potential liability of SUMMIT Microelectronics, Inc. is adequately protected under the circumstances.

© Copyright 2007 SUMMIT MICROELECTRONICS, Inc. **PROGRAMMABLE POWER FOR A GREEN PLANET™**

ADOC™ and Sequence-Link™ are registered trademarks of Summit Microelectronics Inc., I²C is a trademark of Philips Corporation.