

Programmable Linear Battery Charger in 1.3 x 2.1 uCSP™

FEATURES & APPLICATIONS

- World's smallest linear charger
- Linear charging for reduced board space
 - Up to 525mA charge current
 - Stable with small ceramic capacitors
- 4.35 to 6.5V input voltage range
- Small 1.3 x 2.1 uCSP™ package (0.5mm pitch)
- High-accuracy output voltage regulation: 1%
- Low reverse leakage current
- Digital programming of all major parameters via I²C interface and lockable non-volatile memory
 - Battery voltage set point
 - Pre-charge, fast charge, termination current
 - Fast charge voltage threshold
 - Temperature limits
 - Charge safety timers
 - Automatic restart threshold
- Fault/Status indicator
- Wide range of protection features
 - Thermal regulation
 - Battery pack temperature monitor
 - Input/output over-voltage lockout

Applications

- Bluetooth & Stereo Headsets
- Noise Cancellation Headphones
- Wireless Handsets
- MP3 Players
- Wrist PDA/Watches
- Handheld Equipment

INTRODUCTION

The SMB239 is a programmable single-cell lithium-ion/lithium-polymer battery charger for a variety of portable applications. The device provides a simple way to charge low- and medium-capacity Li-Ion or Li-Polymer batteries via a USB port or an AC port. Unlike conventional devices, the SMB239's very small package and high level of configurability simplify design in a wide range of handheld equipment.

Charge control includes qualification, trickle-charge, pre-charge, constant current/constant voltage, and termination/safety settings that are fully programmable via a serial I²C/SMBus making the device truly a flexible solution. Pre-charge, fast charge and termination current levels can be set via I²C commands. The SMB239 offers the option to automatically recharge the battery upon power cycling, only when battery voltage falls 220/390/550mV below the selectable float voltage. This allows for a reduced number of charge/discharge cycles, thereby extending battery life.

The SMB239 offers a wide variety of features that protect the battery pack as well as the charger and input circuitry: over-current, under- and over-voltage, and thermal protection. Ultra-precise, 1% accurate, float voltage control improves battery capacity utilization. Status can be monitored via the serial port for charge state and fault conditions. In addition, one LED driver output can be used to signal charge status. As a protection mechanism, when the junction temperature approaches approximately 110°C, the SMB239 will start to reduce charge current to ensure device and system reliability, while charging the battery cell as fast as possible.

The SMB239 is available in a space-saving, 1.3mm x 2.1mm 8-ball uCSP™ package with lead-free balls and is rated over the -30°C to +85°C temperature range.

SIMPLIFIED APPLICATIONS DRAWING

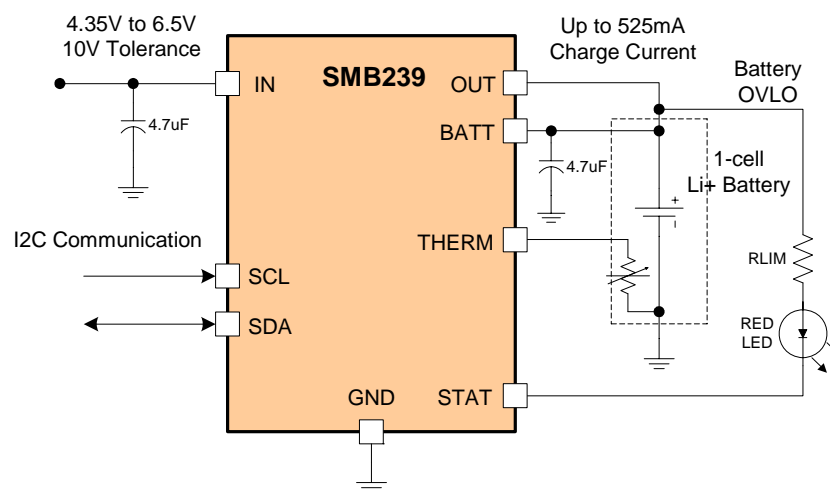

Figure 1 – Applications block diagram featuring the SMB239 programmable linear battery charger.



GENERAL DESCRIPTION

The SMB239 is a fully programmable, linear battery charger for single-cell Li-Ion and Li-Polymer battery packs. The device's simple, linear-mode operation and ultra-small package significantly reduce component count and required board space. The SMB239 provides four main charging phases: trickle-charge, pre-conditioning (pre-charge), constant current and constant voltage. The overall system accuracy of the SMB239 is 1%, allowing for a higher capacity utilization versus other conventional solutions.

When a battery or an external supply is inserted the SMB239 performs the pre-qualification checks before initiating a charging cycle. The input voltage needs to be higher than the UVLO threshold for the charging cycle to start. As soon as the input supply is removed, the SMB239 enters a shutdown mode, thereby saving battery power. A programmable option also exists that allows the user to prevent battery charging until an I²C command has been issued.

If the battery voltage is below 2.0V (trickle-charge to pre-charge threshold), the device will apply a trickle-charge current of 10mA (typical). This allows the SMB239 to reset the protection circuit in the battery pack and bring the battery voltage to a higher level without compromising safety.

Once the battery voltage crosses the 2.0V threshold, the SMB239 enters the pre-charge mode. This mode replenishes deeply depleted cells and minimizes heat dissipation during the initial charge cycle. The preconditioning current is programmable, with the default value at C/10. If the battery voltage does not reach the preconditioning voltage level (programmable) within a specified amount of time (pre-charge timeout), the safety timer expires and the charge cycle is terminated.

When the battery voltage reaches the pre-charge to fast-charge voltage level, the SMB239 enters the constant current (fast charge) mode. The fast charge current level is programmable via the corresponding register.

Once the final float voltage (programmable) has been reached, the battery charger will enter a constant voltage mode in which the battery voltage is kept constant, allowing the charge current to gradually taper off. The constant-voltage charging mode will continue until the charge current drops below the termination current threshold, or until the fast charge timer has expired. The termination current threshold is programmable.

After the charge cycle has terminated, the SMB239 continues to monitor the battery voltage. If the battery voltage falls below the recharge threshold (typically 115mV below float voltage), the SMB239 can automatically top-off the battery.

An option exists for preventing charging initiation upon power cycling unless the battery voltage is 220mV, 390mV or 550mV (V_{CH}) below the float voltage level. This prevents over-stressing of the battery via continuous charging cycles in systems with short run times and frequent power cycling (IN power connect/disconnect).

A wide range of protection features is also included in the SMB239. These include input and output (battery) over-voltage protection, battery missing detector and thermal monitor for continuous cell temperature monitoring and pre-qualification.

The following charging parameters can be adjusted dynamically via the I²C interface, for optimizing battery management real-time. These parameters can also be programmed statically via a user-friendly GUI interface:

- Battery (float) voltage
- Fast charge current
- Pre-conditioning voltage threshold
- Pre-conditioning charge current
- Termination current
- Temperature window
- Safety charge timers.



INTERNAL BLOCK DIAGRAM

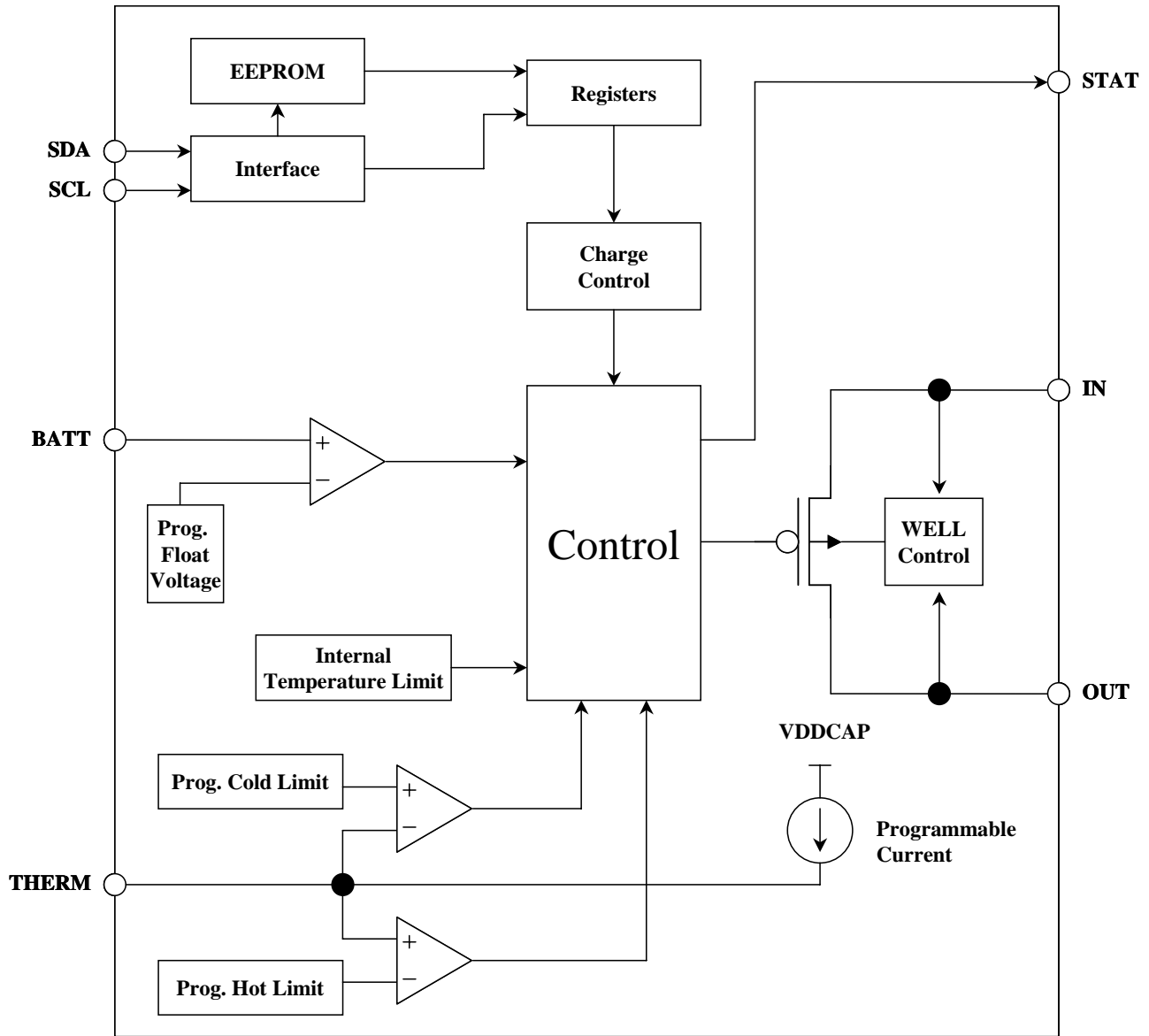
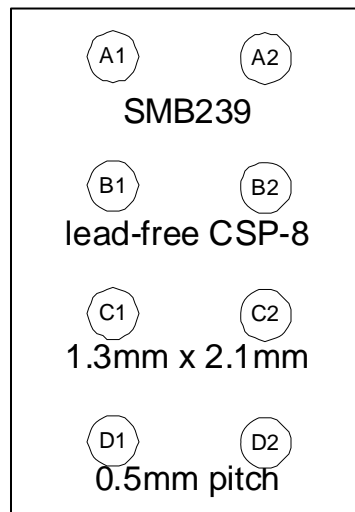

Figure 2 – Internal block diagram of the SMB239 programmable linear battery charger.

**SMB239 PRODUCTION PACKAGE AND PIN DESCRIPTIONS**

Ball Number	Ball Name	Ball Type	Pin Description
A1	BATT	Input	Battery Voltage Sense – Connect directly to positive terminal of battery and bypass with a 4.7uF or greater capacitor.
B1	GND	Ground	Ground – Connect to isolated PCB ground.
C1	STAT	Output	Status Indicator.
D1	IN	Input	Voltage Input (+4.35V to +6.5V) – Bypass with a 4.7uF or greater capacitor.
A2	THERM	Input	Battery Thermistor Sense.
B2	SDA	Input/Output	I ² C Bus Data.
C2	SCL	Input	I ² C Bus Clock.
D2	OUT	Output	Charge Current Output.



Bottom View
(Balls facing up)



ENGINEERING PACKAGE AND PIN DESCRIPTIONS

Pin Number	Pin Name	Pin Type	Pin Description
1	BATT	Input	Battery Voltage Sense – Connect directly to positive terminal of battery and bypass with a 4.7uF or greater capacitor.
3, 8, 18, 20, 22, 30, 32, 33	GND	Ground	Ground – Connect to isolated PCB ground.
10	STAT	Output	Status Indicator.
12	IN	Input	Voltage Input (+4.35V to +6.5V) – Bypass with a 4.7uF or greater capacitor.
29	THERM	Input	Battery Thermistor Sense.
21	SDA	Input/Output	I ² C Bus Data.
19	SCL	Input	I ² C Bus Clock.
14	OUT	Output	Charge Current Output.

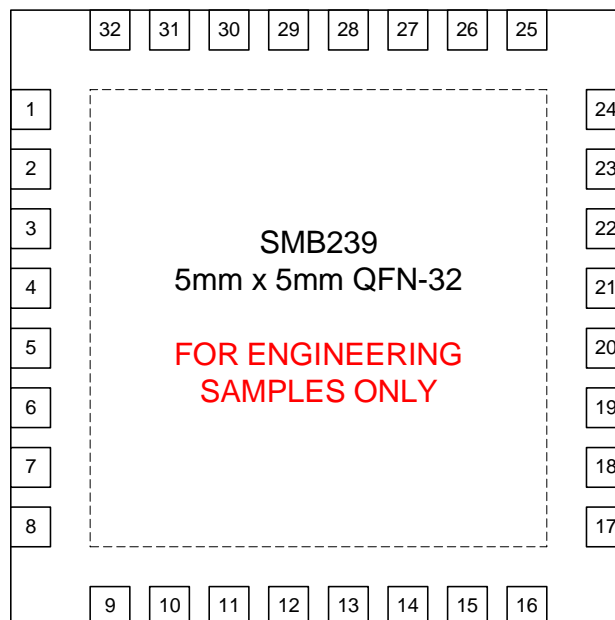



ABSOLUTE MAXIMUM RATINGS

Temperature Under Bias -55°C to 155°C
 Storage Temperature..... -55°C to 125°C
 Terminal Voltage with Respect to GND:
 VIN -0.3V to +10V
 All Others-0.3V to 6V
 Output Short Circuit Current 100mA
 Lead Solder Temperature (10 s).....300°C
 Junction Temperature.....150°C
 HBM ESD Rating per JEDEC.....4000V
 MM ESD Rating per JEDEC.....200V
 CDM ESD Rating per JEDEC.....1000V
 Latch-Up testing per JEDEC.....±100mA

Note: The device is not guaranteed to function outside its operating rating. Stresses listed under Absolute Maximum Ratings may cause permanent damage to the device. These are stress ratings only and functional operation of the device at these or any other conditions outside those listed in the operational sections of the specification is not implied. Exposure to any absolute maximum rating for extended periods may affect device performance and reliability. Devices are ESD sensitive. Handling precautions are recommended.

RECOMMENDED OPERATING CONDITIONS

Extended Temperature Range..... -30°C to +85°C
 VIN+4.35V to +6.5V

Package Thermal Resistance (θ_{JA})
 uCSP™-8.....68°C/W

Note: measured on a 2" x 2", 4-layer PCB with a copper weight of 1oz for each of the top, PWR, GND, and bottom layer.

RELIABILITY CHARACTERISTICS

Data Retention.....100 Years
 Endurance.....100,000 Cycles

DC OPERATING CHARACTERISTICS

$T_A = -30^\circ\text{C}$ to $+85^\circ\text{C}$, $V_{IN} = +5.0\text{V}$, $V_{FLOAT} = +4.2\text{V}$ unless otherwise noted. All voltages are relative to GND.

Symbol	Parameter	Conditions	Min	Typ	Max	Unit
General						
V_{IN}	Input supply voltage	$V_{FLT} = 4.2\text{V}$	+4.35		+6.5	V
V_{UVLO}	Under-voltage lockout voltage	$V_{FLT} = 4.2\text{V}$		+3.5		V
$V_{UVLO-HYS}$	Under-voltage lockout hysteresis	$V_{FLT} = 4.2\text{V}$		10		mV
V_{OVLO}	Input over-voltage lockout voltage			+7.0		V
V_{VOB}	Battery over-voltage lockout voltage			$V_{FLT}+0.1$		V
V_{ASHDN}	Automatic shutdown threshold voltage	$V_{IN} - V_{BATT}$		130		mV
$I_{IN-ACTIVE}$	Active supply current			0.7		mA
$I_{IN-DISABLE}$	Disable supply current	Input voltage present		0.7		mA
I_{LK}	Reverse leakage current	$V_{IN} < V_{BATT}$, $T=0^\circ\text{C}$ to $+70^\circ\text{C}$			2	μA
T_{REG}	Thermal regulation temperature			110		$^\circ\text{C}$



DC OPERATING CHARACTERISTICS (CONTINUED)

$T_A = -30^{\circ}\text{C}$ to $+85^{\circ}\text{C}$, $V_{IN} = +5.0\text{V}$, $V_{FLOAT} = +4.2\text{V}$ unless otherwise noted. All voltages are relative to GND.

Symbol	Parameter	Conditions	Min	Typ	Max	Unit
Logic Inputs/Output						
V_{IL}	Input Low Level				600	mV
V_{IH}	Input High Level		1.4			V
V_{OL}	SDA/STAT Output Low Level	$I_{SINK} = 3\text{mA}$			300	mV
I_{SINK}	STAT sink current	$V_{OL} = 0.4\text{V}$		5		mA
Battery Charger						
$V_{TRICKLECHG}$	Trickle-charge to pre-charge voltage threshold			2.0		V
$I_{TRICKLECHG}$	Nominal trickle-charge current	$V_{BATT} = 1.5\text{V}$		10		mA
V_{PRECHG}	Pre-charge to fast-charge voltage threshold	100mV steps	2.400		3.100	V
I_{PRECHG}	Nominal pre-charge current range	16 steps	25		212.5	mA
ΔI_{PRECHG}	Pre-charge current tolerance	$I_{PRECHG} = 100\text{mA}$, $T = 0^{\circ}\text{C}$ to $+70^{\circ}\text{C}$	75	100	125	mA
I_{CHG}	Nominal Fast charge current range	16 steps	47.5		525	mA
ΔI_{CHG}	Fast charge current tolerance	$I_{CHG} = 375\text{mA}$, $V_{IN} = 4.5\text{V}$ to 5.5V , $T = 0^{\circ}\text{C}$ to $+70^{\circ}\text{C}$, $V_{BATT} = 3.0\text{V}$ to 4.2V , Note 3	340	375	400	mA
			-9.3		+6.7	%
$I_{CHGDROP}$	Fast charge current in dropout	$I_{CHG} = 375\text{mA}$, $V_{IN} = 4.35\text{V}$, $V_{BATT} = 4.2\text{V}$, $T = 0^{\circ}\text{C}$ to $+70^{\circ}\text{C}$, No automatic shutdown triggered, Note 4	300	340		mA
V_{FLT}	Float voltage range	20mV steps	4.020		4.400	V
ΔV_{FLT}	Float voltage tolerance	$T = +10^{\circ}\text{C}$ to $+50^{\circ}\text{C}$, $V_{FLT} = 4.2\text{V}$	-1		+1	%
V_{DO}	Dropout voltage	$I_{CHG} = 100\text{mA}$		55		mV
I_{TERM}	Charge termination current range	16 steps	25		250	mA
ΔI_{TERM}	Termination current tolerance	$I_{TERM} = 55\text{mA}$, $T = 0^{\circ}\text{C}$ to $+70^{\circ}\text{C}$	35	55	70	mA
V_{RECH}	Recharge threshold voltage			115		mV
V_{CH}	Charge threshold voltage range after power applied	3 steps, $V_{BATT} < V_{FLT} - V_{CH}$	220		550	mV
I_{THERM}	Thermistor current	3 settings	10		100	μA
ΔI_{THERM}	Thermistor current tolerance	$I_{THERM} = 100\mu\text{A}$, $T = 0^{\circ}\text{C}$ to $+70^{\circ}\text{C}$	90	100	110	μA
T_{HI}	Charge cutoff temp (high)	Adjustable, conditions per typical application	30		65	$^{\circ}\text{C}$
T_{LO}	Charge cutoff temp (low)	Adjustable, conditions per typical application	-20		15	$^{\circ}\text{C}$

**AC OPERATING CHARACTERISTICS** **$T_A = -30^{\circ}\text{C}$ to $+85^{\circ}\text{C}$, $V_{IN} = +5.0\text{V}$, $V_{FLOAT} = +4.2\text{V}$ unless otherwise noted. All voltages are relative to GND.**

Symbol	Parameter	Conditions	Min	Typ	Max	Unit
t_{START}	Start-up time			20		msec
t_{GLITCH}	Glitch filter	Disabled		0		msec
		Enabled		250		msec
$t_{HOLDOFF}$	Hold-off time	Short	0		1	msec
		Long		256		msec
t_{FCTO}	Fast-charge Timeout	$t_{FCTO} = 350\text{min}$	-15	t_{FCTO}	+15	%
		$t_{FCTO} = 699\text{min}$				
		$t_{FCTO} = 2398\text{min}$				
t_{PCTO}	Pre-charge Timeout	$t_{PCTO} = 44\text{min}$	-15	t_{PCTO}	+15	%
		$t_{PCTO} = 87\text{min}$				
		$t_{PCTO} = 175\text{min}$				

Note 1: Voltage and current accuracies are only guaranteed for factory-programmed settings. Changing the output voltage from that reflected in the customer specific CSIR code will result in inaccuracies exceeding those specified above.

Note 2: The SMB239 device is not intended to function as a battery pack protector. Battery packs used in conjunction with this device need to provide adequate internal protection and to comply with the corresponding battery pack specifications.

Note 3: Assumption: part does not operate in dropout.

Note 4: Not 100% Production Tested. Guaranteed by Design and Characterization.



CHARGING ALGORITHM

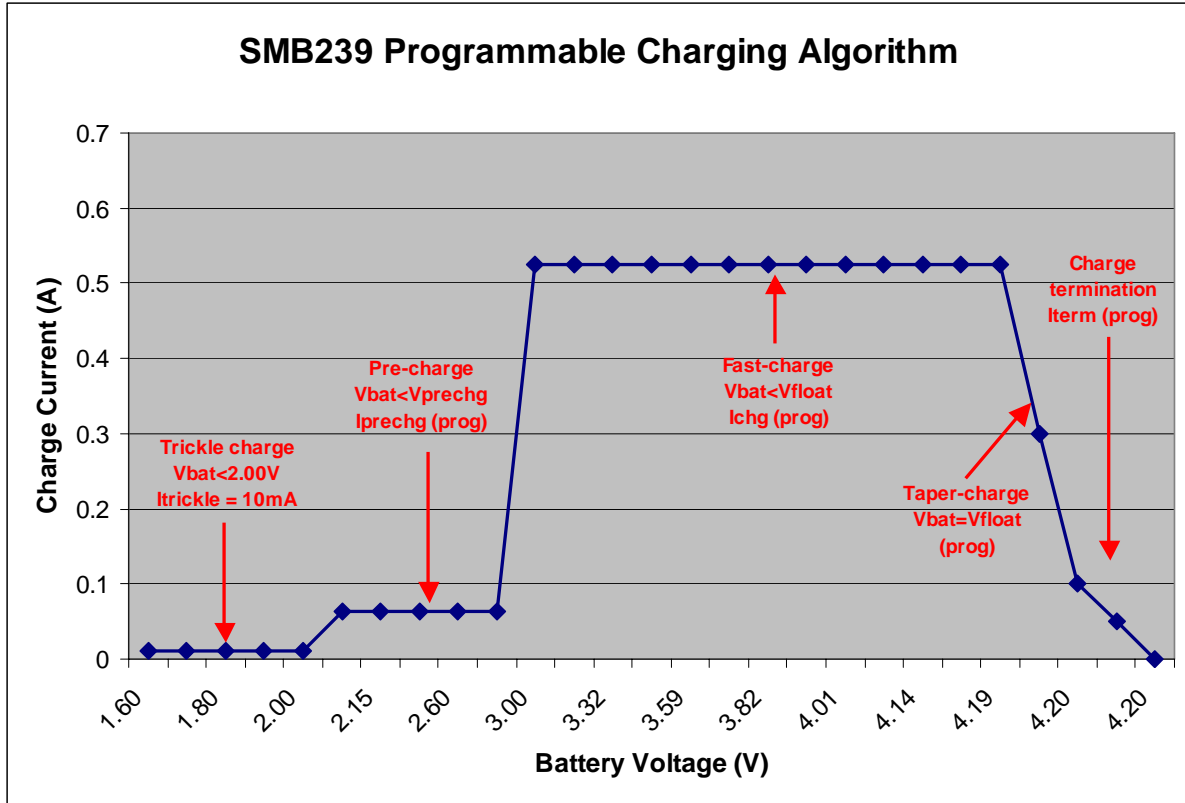

Figure 3 – SMB239 Programmable Charging Algorithm



I²C-2 WIRE SERIAL INTERFACE AC OPERATING CHARACTERISTICS – 400 kHz

T_A = 0°C to +70°C, V_{IN} = +5.0V, V_{FLOAT} = +4.2V unless otherwise noted. All voltages are relative to GND.

Symbol	Description	Conditions	400kHz			
			Min	Typ	Max	Units
f _{SCL}	SCL clock frequency		0		400	kHz
T _{LOW}	Clock low period		1.3			μs
T _{HIGH}	Clock high period		0.6			μs
t _{BUF}	Bus free time between a STOP and a START condition	Before new transmission – Note 4	1.3			μs
t _{SU:STA}	Start condition setup time		0.6			μs
t _{HD:STA}	Start condition hold time		0.6			μs
t _{SU:STO}	Stop condition setup time		0.6			μs
t _{AA}	Clock edge to data valid	SCL low to valid SDA (cycle n)	0.2		0.9	μs
t _{RDH}	Data output hold time	SCL low (cycle n+1) to SDA change	0.2			μs </td
t _R	SCL and SDA rise time	Note 4	20 + 0.1C _b		300	ns
t _F	SCL and SDA fall time	Note 4	20 + 0.1C _b		300	ns
t _{SU:DAT}	Data in setup time		100			ns
t _{HD:DAT}	Data in hold time		0		0.9	μs
TI	Noise filter SCL and SDA	Noise suppression		140		ns
t _{WR_CONFIG}	Write cycle time config	Configuration registers	10			ms
t _{WR_EE}	Write cycle time EE	Memory array	5			ms

I²C TIMING DIAGRAMS

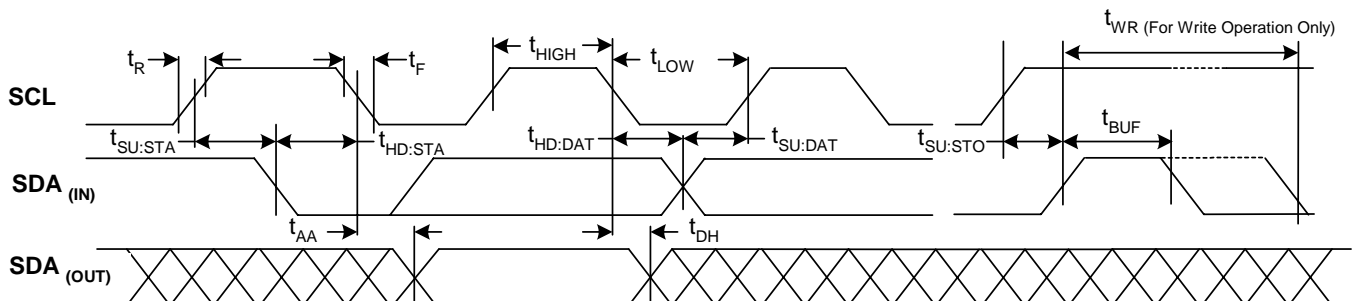

Figure 4 – I²C Timing Diagrams



APPLICATIONS INFORMATION

DEVICE OPERATION

The SMB239 is a fully programmable battery charger for single-cell Li-Ion and Li-Polymer battery packs. The device's simple, linear-mode operation and ultra-small package significantly reduce component count and required board space. The SMB239 provides four main charging phases: trickle-charge, pre-conditioning (pre-charge), constant (fast-charge) current and constant voltage. The overall system accuracy of the SMB239 is 1%, allowing for a higher capacity utilization versus other conventional solutions. The main battery charging parameters are programmable, allowing for high design flexibility and sophisticated battery management. Furthermore, the SMB239 offers many advanced protection features, allowing applications to meet strict safety standards without the need for additional cost and components.

Power Supply

The SMB239 can be powered from an input voltage between +4.35 and +6.5 Volts applied between the IN pin and ground. The voltage on the IN pin is monitored by an Under-Voltage (UVLO) circuit, which prevents the charger from turning on when the voltage at this node is less than the UVLO threshold (+3.5V). The IN pin also supplies an internal +2.5V VDD regulator, which is used as an internal VDD supply. When the input supply is removed, the SMB239 enters a low-power shutdown mode, exhibiting a very low discharge leakage current (2 μ A), thereby extending battery life.

Pre-qualification Mode

When an external wall adaptor or another type of power source is connected, the SMB239 performs a series of pre-qualification tests before initiating the first charge cycle. The input voltage level needs to be higher than the UVLO threshold, and 130mV greater than the battery voltage; and the appropriate I2C command (enable/disable) needs to be asserted. The pre-qualification parameters are continuously monitored and charge cycle is suspended when one of them is outside the limits.

A device option exists (controlled by register 0Ch) for preventing charging initiation upon power cycling unless the battery voltage is 200mV, 390mV or 550mV (V_{CH}) below the float voltage level. This prevents over-stressing of the battery via continuous charging cycles in systems with short run times and frequent power cycling (IN power connect/disconnect).

Trickle-charge Mode

Once all pre-qualification conditions are met, the device checks the battery voltage to decide if trickle-charging

is required. If the battery voltage is below approximately 2.0V, a charging current of 10mA (typical) is applied on the battery cell. This allows the SMB239 to reset the protection circuit in the battery pack and bring the battery voltage to a higher level without compromising safety.

Pre-charge Mode

Once the battery voltage crosses the 2.0V level, the SMB239 pre-charges the battery to safely charge the deeply discharged cells (Figure 3). The pre-charge (pre-conditioning) current is programmable from 25mA to 212.5mA (Register 00h). The SMB239 remains in this mode until the battery voltage reaches the pre-charge to fast-charge voltage threshold (programmable from +2.4V to +3.1V in 100mV steps). If the pre-charge to fast-charge voltage threshold is not exceeded before the pre-charge timer expires, the charge cycle is terminated and a corresponding timeout fault signal is asserted ("Pre-charge Timeout" in register 36h).

Constant Current Mode

When the battery voltage exceeds the pre-charge to fast-charge voltage threshold, the device enters the constant current (fast charge) mode. During this mode, the fast charge current level is set by the corresponding register. The fast charge current is programmable from 47.5mA to 525mA (Register 00h).

Constant Voltage Mode

When the battery voltage reaches the pre-defined float voltage, the fast-charge current starts diminishing. The float voltage is programmable from +4.020V to +4.40V in 20mV steps and is $\pm 1\%$ accurate over the +10°C to +50°C temperature range. The higher float voltage settings of the SMB239 enable the charging of modern battery packs with a required float voltage of 4.3V, and 4.4V. Furthermore, the ability to dynamically adjust the float voltage allows the implementation of sophisticated battery charging and control algorithms.

Charge Completion

The charge cycle is considered complete when the charge current reaches the programmed termination current threshold. The termination current is programmable from 25mA to 250mA (Register 01h). If the termination current threshold is not met before the fast-charge timer expires, the charge cycle is terminated and a corresponding timeout fault signal is asserted ("Fast-charge Timeout" in register 36h).



APPLICATIONS INFORMATION (CONTINUED)

Automatic Battery Recharge

The SMB239 allows the battery to be automatically recharged (topped off) when the battery voltage falls by a value of V_{RECH} (115mV typical) below the programmed float voltage. Provided that the input power supply is still present, charging remains enabled (I^2C command) and all the pre-qualification parameters are still met, a new charging cycle will be initiated. This ensures that the battery capacity remains high, without the need to manually re-start a charging cycle. The automatic battery recharging can be disabled if not required by the application (Register 03h).

USB500/100

USB500/100 allows the user to select a maximum fast charge current of 87mA or 525mA. The USB500/100 functionality is controlled over the I2C interface, allowing for full software control of charge current levels. This function is accomplished via register 31 bit 3, when Register 7 bit 0 is programmed high.

When the USB500 mode is selected, the charge current level may be as high as 525mA. When the USB100 mode is selected, the charge current level is limited to 87mA. ***In all cases, a lower register value setting will impose an overriding current limit.***

Safety Timers

The integrated safety timers provide protection in case of a defective battery pack. The pre-charge timer starts after the pre-qualification check is completed and resets when the transition to the constant current mode happens. At that point, the fast charge timer is initiated. The fast charge timer expires and charge cycle is terminated if the termination current level is not reached within the pre-determined duration. Each safety timer has three programmable timeout periods, which eliminates the need for external timing capacitors and allows for maximum design flexibility. In addition, each timer can be disabled by the appropriate bit selection in Register 05h.

STAT Output

The STAT is an open-drain output that indicates battery charge status. STAT has two modes of operation, as determined by Register 05h[7]: in Mode 0, STAT is asserted low whenever the battery is charging and de-asserted at all other times; in Mode 1, STAT is de-asserted when the charger is disabled, blinks during charging, and remains continuously asserted when the charge cycle has completed. A pull-up resistor should be applied on this pin for interfacing to a microcontroller or other logic IC.

Programmable Battery Charging

A unique feature of the SMB239 is the ability to modify all of the important charger parameters via internally

programmable EEPROM, found in Registers 00-07. Once the device has been configured correctly, the EEPROM may be locked, preventing any further changes. Additionally, these registers may also be configured so that they may be updated in RAM (volatile), even if the underlying EEPROM is locked. This feature is useful if it is desired to actively manage the charging profile without making changes to the non-volatile defaults. Use Register 0E to control locking and volatile access. Before writing to Registers 00-07 in a volatile manner, Register 31[7] must first be set high.

FAULT and STATUS Indicators

A large number of battery charging conditions and parameters are monitored and corresponding fault and status indications are available to the user via the I^2C compatible registers. These include the following:

- Charging status
- Safety timer timeout
- Over-temperature alarm
- Under-temperature alarm
- Over-voltage alarm
- Under-voltage alarm
- Missing battery detection

Thermal Monitor

A temperature sensing I/O (THERM) is provided to prevent excessive battery temperatures during charging. The battery temperature is measured by sensing the voltage between the THERM pin and ground. The voltage is created by injecting a current into the parallel combination of Negative Temperature Coefficient (NTC) thermistor and a resistor. This voltage is then compared to two predetermined voltages representing the maximum and minimum temperature settings of the battery. The purpose of the resistor in parallel to the NTC thermistor is to linearize the resistance of the thermistor. Table 1, shows the 1% resistor that should be placed in parallel with the corresponding thermistor.

If the temperature limits are exceeded, battery charging will be suspended until the temperature level has fallen within the safe operating range. The over-temperature limit is programmable from 30°C to 65°C, and the under-temperature limit is programmable from -20°C to 15°C, each in 5°C increments using Register 04h. In addition, the user can easily select the required bias current, based on the value of the negative temperature coefficient (NTC) thermistor located in the battery pack: 10k, 25k, 100k (Register 04h). Disabling the thermal monitor is also possible by selecting the appropriate bits in Register 04h.



APPLICATIONS INFORMATION (CONTINUED)

As the temperature changes, the resistance of the thermistor changes creating a voltage proportional to temperature. The temperature coefficient or Beta (B) of the thermistor must be as close to 4400 as possible to achieve the maximum temperature accuracy.

NTC THERMISTOR	RESISTANCE
10K	24.9K
25K	61.9K
100K	249K

Table 1: NTC values and associated parallel resistances.

Internal Thermal Protection

When the die temperature of the SMB239 reaches approximately 110°C, charge current will be reduced to prevent further die heating. This internal thermal protection circuit helps to improve device (and consequently, system) reliability.

**APPLICATIONS INFORMATION (CONTINUED)****EXTERNAL COMPONENTS****Input and Output Capacitors**

The SMB239 allows for the use of low-cost ceramic capacitors on both the input and the output. The minimum input capacitance value is 4.7 μ F. The minimum output capacitance of 4.7 μ F is desired in parallel with the battery installed on the BATT pin. Taking account of the temperature degrading characteristics of ceramic capacitors, one is encouraged to select X5R or X7R rated ceramic capacitors.

BOARD LAYOUT RECOMMENDATIONS

The most critical components for the reliable operations of the SMB239 are the output capacitor and the input capacitor. Place those as close as possible to the SMB239. Pour sufficient copper along the power delivery path, namely, from the power source to the IN pin and from the OUT pin to the battery. This minimizes the distribution loss, therefore buys an additional margin for the IN-to-OUT drop-out voltage. Route the BATT pin to the positive terminal of the battery by traces wider than 10mils.

POWER DISSIPATION

The SMB239 incorporates a thermal regulation circuit that reduces charge current when die temperature rises to high levels (greater than 110°C). The conditions under which this charge current reduction finds place can be determined by calculating device power dissipation. Most of the SMB239 power dissipation is generated in the internal power MOSFET. The worst-case scenario occurs when the input voltage is at its highest level and the device has transitioned from the pre-charge to the fast-charge phase. In this case, both the input-to-output differential and the charge current level are large, resulting in high thermal dissipation.

Actual power dissipation can be calculated by using the following formula:

$$PD_{ACTUAL} = (VIN - VBATT) \times IOUT$$

Where:

VIN = input (adapter or USB port) voltage

VBATT = battery voltage

IOUT = charge current

Assuming the SMB239 operates from a 5V \pm 10% (worst case: 5.5V) supply and is configured to deliver a charge current of 200mA to a discharged Li-Ion battery with a voltage of 3.6V, the power dissipation can be calculated as follows:

$$PD_{ACTUAL} = (5.5V - 3.5V) \times 0.3A = 600mW$$

The maximum allowable power dissipation for a specific package and board layout can be calculate by using the following formula:

$$PD_{MAXIMUM} = (TJ - TA) / Theta_{JA}$$

Where:

TJ = maximum allowable junction (silicon) temperature

TA = maximum ambient temperature

Theta_{JA} = package thermal resistance (depends highly on board layout)

Combining the two formulas (actual and maximum allowable power dissipation) allows the user to calculate the ambient temperature at which the SMB239 will start reducing charge current for safe operation. By using our example above and an estimated Theta_{JA} of 60°C/W, the ambient temperature can be calculated as follows:

$$\begin{aligned} TA &= TJ - (PD_{MAXIMUM} \times Theta_{JA}) \\ &= TJ - (VIN - VBATT) \times IOUT \times Theta_{JA} \\ &= 110^{\circ}C - (5.5V - 3.5V) \times 0.30A \times 60^{\circ}C/W \\ &= 74^{\circ}C \end{aligned}$$



APPLICATIONS INFORMATION (CONTINUED)

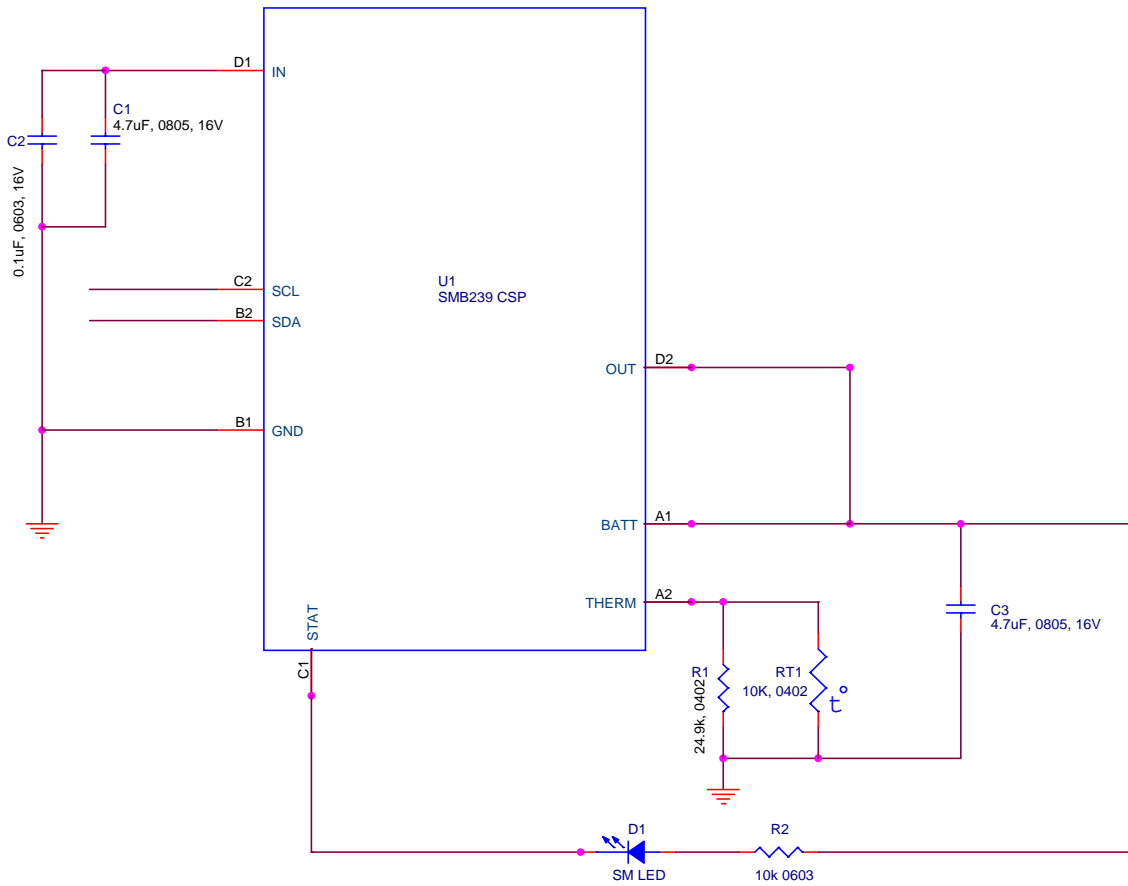

Figure 6 – Typical applications schematic.

**APPLICATIONS INFORMATION (CONTINUED)****Table 2: Recommended Bill of Material.**

Item	Description	Vendor / Part Number	Qty	Ref. Des.
Resistors				
1	Resistor, 24.9k, 0402, 1%	Vishay# CRCW04022492F	1	R1
2	Resistor, 10k, 0603, 1%	Vishay# CRCW06031002F	1	R2
3	Thermistor, 10k, 0402	TDK# NTCG103JF103FT	1	RT
Capacitors				
4	Ceramic, 4.7uF, X5R, 16V, 0805	Murata# GRM40X5R475K16D520	2	C1, C3
5	Ceramic, 0.1uF, X7R, 16V, 0603	Kemet # C0603C104K4RACTU	1	C2
Semiconductors				
6	SMB239E (CSP), Linear Charger	Summit Microelectronics	1	U1
7	LED, Red, SMD, 0805	Lite-On# LTST-C190CKT	1	D1



DEVELOPMENT HARDWARE & SOFTWARE

The SMX3202 system consists of a USB programming Dongle, cable and Windows™ GUI software. It can be ordered on the website or from a local representative. The latest revisions of all software and an application brief describing the SMX3202 is available from the website (www.summitmicro.com).

The SMX3202 programming Dongle/cable interfaces directly between a PC's USB port and the target application. The device is then configured on-screen via an intuitive graphical user interface employing drop-down menus.

The Windows GUI software will generate the data and send it in I²C serial bus format so that it can be directly downloaded to the SMB239 via the programming Dongle and cable. An example of the connection interface is shown in Figure 9.

When design prototyping is complete, the software can generate a HEX data file that should be transmitted to Summit for approval. Summit will then assign a unique customer ID to the HEX code and program production devices before the final electrical test operations. This will ensure proper device operation in the end application.

Top view of straight 0.1" x 0.1" closed-side connector. SMX3202 interface cable connector.

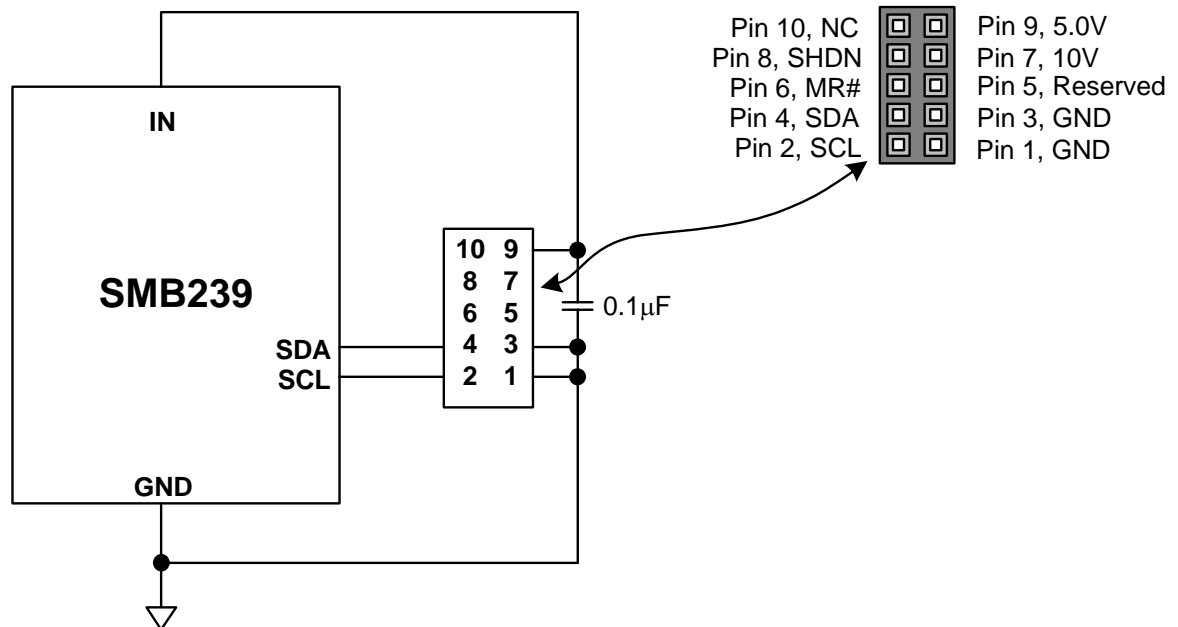



I²C PROGRAMMING INFORMATION

SERIAL INTERFACE

Access to the configuration registers, command and status registers is carried out over an industry standard 2-wire serial interface (I²C). SDA is a bi-directional data line and SCL is a clock input (Figure4). Data is clocked in on the rising edge of SCL and clocked out on the falling edge of SCL. All data transfers begin with the MSB. During data transfers, SDA must remain stable while SCL is high. Data is transferred in 8-bit packets with an intervening clock period in which an Acknowledge is provided by the device receiving data. The SCL high period (t_{HIGH}) is used for generating Start and Stop conditions that precede and end most transactions on the serial bus. A high-to-low transition of SDA while SCL is high is considered a Start condition while a low-to-high transition of SDA while SCL is high is considered a Stop condition.

The interface protocol allows operation of multiple devices and types of devices on a single bus through unique device addressing. The address byte is comprised of a 7-bit device type identifier (slave address). The remaining bit indicates either a read or a write operation. Refer to Table 1 for a description of the address bytes used by the SMB239.

The device type identifier for the configuration registers and the command and status registers are accessible with the same slave address. The slave address can be programmed to any seven bit number 0000000_{BIN} through 1111111_{BIN}. Table 3.

WRITE

Writing to a configuration register is illustrated in Figures 10 and 11. A Start condition followed by the slave address byte is provided by the host; the SMB239 responds with an Acknowledge; the host then responds by sending the memory address pointer or configuration register address pointer; the SMB239 responds with an acknowledge; the host then clocks in one byte of data. For configuration register writes, up to 15 additional bytes of data can be clocked in by the host to write to consecutive addresses within the same page.

After the last byte is clocked in and the host receives an Acknowledge, a Stop condition must be issued to initiate the nonvolatile write operation.

READ

The address pointer for the non-volatile configuration registers and memory registers as well as the volatile command and status registers must be set before data can be read from the SMB239. This is accomplished by issuing a dummy write command, which is a write command that is not followed by a Stop condition. A dummy write command sets the address from which data is read. After the dummy write command is issued, a Start command followed by the address byte is sent from the host. The host then waits for an Acknowledge and then begins clocking data out of the slave device. The first byte read is data from the address pointer set during the dummy write command. Additional bytes can be clocked out of consecutive addresses with the host providing an Acknowledge after each byte. After the data is read from the desired registers, the read operation is terminated by the host holding SDA high during the Acknowledge clock cycle and then issuing a Stop condition. Refer to Figure 12 for an illustration of the read sequence.

CONFIGURATION REGISTERS

Writing and reading the configuration registers is shown in Figures 10, 11 and 12. A description of the configuration registers is shown in Table 3 through Table 12.

GRAPHICAL USER INTERFACE (GUI)

Device configuration utilizing the Windows based SMB239 graphical user interface (GUI) is highly recommended. The software is available from the Summit website (www.summitmicro.com). Using the GUI in conjunction with this datasheet, simplifies the process of device prototyping and the interaction of the various functional blocks. A programming Dongle (SMX3202) is available from Summit to communicate with the SMB239. The Dongle connects directly to the USB port of a PC and programs the device through a cable using the I²C bus protocol. See Figure 9 and the SMX3202 Data Sheet.

Slave Address	Register Type
ALL	Configuration Registers are located in 00 _{HEX} thru 05 _{HEX} , 07 _{HEX} , 0C _{HEX} , 0E _{HEX} and 0F _{HEX}

Table 3 – Address bytes used by the SMB239.



I²C PROGRAMMING INFORMATION (CONTINUED)

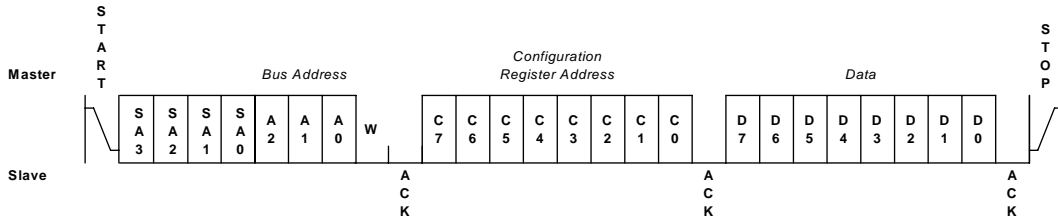

Figure 10 – Configuration Register Byte Write

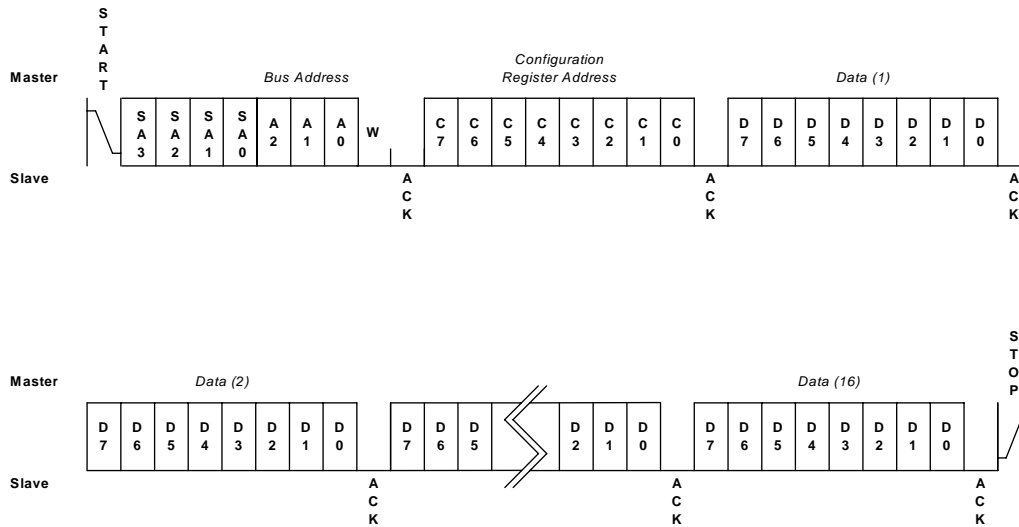

Figure 11 – Configuration Register Page Write

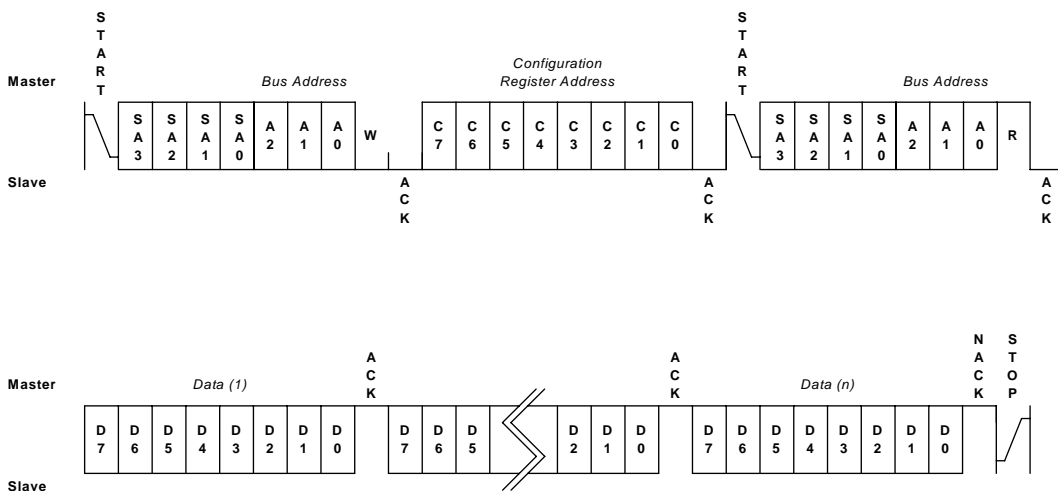

Figure 12 – Configuration Register Read



CONFIGURATION REGISTERS

The following tables describe the user-programmable registers of the SMB239 programmable battery charger. Locations 00-0F are non-volatile, EEPROM registers; however, registers 00-07, which contain the battery charging parameters, may also be configured to be programmable in RAM. Locations 31-3F contain volatile status and command registers. To lock all of the configuration registers, set 0E[2]=1; **please note that this operation cannot be undone**. To allow volatile access to locations 00-07, set 0E[0]=1; then after every power-on, 31[7] must also be set high. **It is prohibited to write to any location, not specifically mentioned in the tables below (Note 5).**

Table 4 – Charge current – 8-bit (address: 00h) – Non-Volatile & Volatile (mirror)								
Bit7	Bit6	Bit5	Bit4	Bit3	Bit2	Bit1	Bit0	Fast Charge Current
0	0	0	0	X	X	X	X	47.5mA
0	0	0	1	X	X	X	X	62.5mA
0	0	1	0	X	X	X	X	65.0mA
0	0	1	1	X	X	X	X	67.5mA
0	1	0	0	X	X	X	X	195mA
0	1	0	1	X	X	X	X	225mA
0	1	1	0	X	X	X	X	255mA
0	1	1	1	X	X	X	X	285mA
1	0	0	0	X	X	X	X	315mA
1	0	0	1	X	X	X	X	345mA
1	0	1	0	X	X	X	X	375mA
1	0	1	1	X	X	X	X	405mA
1	1	0	0	X	X	X	X	435mA
1	1	0	1	X	X	X	X	465mA
1	1	1	0	X	X	X	X	495mA
1	1	1	1	X	X	X	X	525mA
Bit7	Bit6	Bit5	Bit4	Bit3	Bit2	Bit1	Bit0	Pre-charge current
X	X	X	X	0	0	0	0	25mA
X	X	X	X	0	0	0	1	37.5mA
X	X	X	X	0	0	1	0	50mA
X	X	X	X	0	0	1	1	62.5mA
X	X	X	X	0	1	0	0	75mA
X	X	X	X	0	1	0	1	87.5mA
X	X	X	X	0	1	1	0	100mA
X	X	X	X	0	1	1	1	112.5mA
X	X	X	X	1	0	0	0	125mA
X	X	X	X	1	0	0	1	137.5mA
X	X	X	X	1	0	1	0	150mA
X	X	X	X	1	0	1	1	162.5mA
X	X	X	X	1	1	0	0	175mA
X	X	X	X	1	1	0	1	187.5mA
X	X	X	X	1	1	1	0	200mA
X	X	X	X	1	1	1	1	212.5mA

Note 5: Never Write to Reserved bits.

Note 6: Charge current can be limited by internal current limit under certain conditions.



CONFIGURATION REGISTERS (CONT.)

Table 5 – Termination current – 8-bit (address: 01h) – Non-Volatile & Volatile (mirror)

Bit7	Bit6	Bit5	Bit4	Bit3	Bit2	Bit1	Bit0	Termination Current
X	X	X	X	0	0	0	0	25mA
X	X	X	X	0	0	0	1	40mA
X	X	X	X	0	0	1	0	55mA
X	X	X	X	0	0	1	1	70mA
X	X	X	X	0	1	0	0	85mA
X	X	X	X	0	1	0	1	100mA
X	X	X	X	0	1	1	0	115mA
X	X	X	X	0	1	1	1	130mA
X	X	X	X	1	0	0	0	145mA
X	X	X	X	1	0	0	1	160mA
X	X	X	X	1	0	1	0	175mA
X	X	X	X	1	0	1	1	190mA
X	X	X	X	1	1	0	0	205mA
X	X	X	X	1	1	0	1	220mA
X	X	X	X	1	1	1	0	235mA
X	X	X	X	1	1	1	1	250mA

Table 6 – Float Voltage – 8-bit (address: 02h) – Non-Volatile & Volatile (mirror)

Bit7	Bit6	Bit5	Bit4	Bit3	Bit2	Bit1	Bit0	Float Voltage
X	X	X	0	0	0	0	0	3.850V
X	X	X	0	0	0	0	1	4.020V
X	X	X	0	0	0	1	0	4.040V
X	X	X	0	0	0	1	1	4.060V
X	X	X	0	0	1	0	0	4.080V
X	X	X	0	0	1	0	1	4.100V
X	X	X	0	0	1	1	0	4.120V
X	X	X	0	0	1	1	1	4.140V
X	X	X	0	1	0	0	0	4.160V
X	X	X	0	1	0	0	1	4.180V
X	X	X	0	1	0	1	0	4.200V
X	X	X	0	1	0	1	1	4.220V
X	X	X	0	1	1	0	0	4.240V
X	X	X	0	1	1	0	1	4.260V
X	X	X	0	1	1	1	0	4.280V
X	X	X	0	1	1	1	1	4.300V
X	X	X	1	0	0	0	0	4.320V
X	X	X	1	0	0	0	1	4.340V
X	X	X	1	0	0	1	0	4.360V
X	X	X	1	0	0	1	1	4.380V
X	X	X	1	0	1	0	0	4.400V

Note 5: Never Write to Reserved bits.



CONFIGURATION REGISTERS (CONT.)

Table 7 – Other Charging Parameters – 8-bit (address: 03h) – Non-Volatile & Volatile (mirror)

Bit7	Bit6	Bit5	Bit4	Bit3	Bit2	Bit1	Bit0	Automatic Recharge
0	X	X	X	X	X	X	X	Enabled
1	X	X	X	X	X	X	X	Disabled
Bit7	Bit6	Bit5	Bit4	Bit3	Bit2	Bit1	Bit0	Current Termination
X	0	X	X	X	X	X	X	Enabled
X	1	X	X	X	X	X	X	Disabled
Bit7	Bit6	Bit5	Bit4	Bit3	Bit2	Bit1	Bit0	Pre-charge to Fast-charge Voltage Threshold
X	X	0	0	0	X	X	X	2.4V
X	X	0	0	1	X	X	X	2.5V
X	X	0	1	0	X	X	X	2.6V
X	X	0	1	1	X	X	X	2.7V
X	X	1	0	0	X	X	X	2.8V
X	X	1	0	1	X	X	X	2.9V
X	X	1	1	0	X	X	X	3.0V
X	X	1	1	1	X	X	X	3.1V
Bit7	Bit6	Bit5	Bit4	Bit3	Bit2	Bit1	Bit0	Hold-off Timer
X	X	X	X	X	X	0	X	<1msec (short)
X	X	X	X	X	X	1	X	256msec (long)
Bit7	Bit6	Bit5	Bit4	Bit3	Bit2	Bit1	Bit0	Charger Error
X	X	X	X	X	X	X	0	Charger Error disallows re-charge cycles
X	X	X	X	X	X	X	1	Charger Errors are blocked

Table 8 – Cell temperature monitor – 8-bit (address: 04h) – Non-Volatile & Volatile (mirror)

Bit7	Bit6	Bit5	Bit4	Bit3	Bit2	Bit1	Bit0	Thermistor Current
0	0	X	X	X	X	X	X	100µA (10k NTC)
0	1	X	X	X	X	X	X	40µA (25k NTC)
1	0	X	X	X	X	X	X	10µA (100k NTC)
1	1	X	X	X	X	X	X	0µA (Disabled)
Bit7	Bit6	Bit5	Bit4	Bit3	Bit2	Bit1	Bit0	Low Temperature Alarm Trip Point
X	X	0	0	0	X	X	X	-20°C
X	X	0	0	1	X	X	X	-15°C
X	X	0	1	0	X	X	X	-10°C
X	X	0	1	1	X	X	X	-5°C
X	X	1	0	0	X	X	X	0°C
X	X	1	0	1	X	X	X	+5°C
X	X	1	1	0	X	X	X	+10°C
X	X	1	1	1	X	X	X	+15°C
Bit7	Bit6	Bit5	Bit4	Bit3	Bit2	Bit1	Bit0	High Temperature Alarm Trip Point
X	X	X	X	X	0	0	0	+30°C
X	X	X	X	X	0	0	1	+35°C
X	X	X	X	X	0	1	0	+40°C
X	X	X	X	X	0	1	1	+45°C
X	X	X	X	X	1	0	0	+50°C
X	X	X	X	X	1	0	1	+55°C
X	X	X	X	X	1	1	0	+60°C
X	X	X	X	X	1	1	1	+65°C



CONFIGURATION REGISTERS (CONT.)

Table 9 – Battery charging control – 8-bit (address: 05h) – Non-Volatile & Volatile (mirror)								
Bit7	Bit6	Bit5	Bit4	Bit3	Bit2	Bit1	Bit0	Status Output
0	X	X	X	X	X	X	X	STAT is active low while charging, active high all other times
1	X	X	X	X	X	X	X	STAT blinks while charging, is active low when finished, active high when disabled
Bit7	Bit6	Bit5	Bit4	Bit3	Bit2	Bit1	Bit0	Glitch Filter
X	X	0	X	X	X	X	X	Glitch filter enabled
X	X	1	X	X	X	X	X	Glitch filter disabled
Bit7	Bit6	Bit5	Bit4	Bit3	Bit2	Bit1	Bit0	Fast-charge Timeout
X	X	X	X	0	0	X	X	350 min
X	X	X	X	0	1	X	X	699 min
X	X	X	X	1	0	X	X	1398 min
X	X	X	X	1	1	X	X	Disabled
Bit7	Bit6	Bit5	Bit4	Bit3	Bit2	Bit1	Bit0	Pre-charge Timeout
X	X	X	X	X	X	0	0	44 min
X	X	X	X	X	X	0	1	87 min
X	X	X	X	X	X	1	0	175 min
X	X	X	X	X	X	1	1	Disabled

Table 10 – STAT Output – 8-bit (address: 07h) – Non-Volatile & Volatile (mirror)								
Bit7	Bit6	Bit5	Bit4	Bit3	Bit2	Bit1	Bit0	STAT Output Indicator
X	X	X	X	X	0	X	X	Battery charge status
X	X	X	X	X	1	X	X	Input over-voltage or input under-voltage
Bit7	Bit6	Bit5	Bit4	Bit3	Bit2	Bit1	Bit0	Battery over-voltage Behavior
X	X	X	X	X	X	0	X	Charger is shutdown
X	X	X	X	X	X	1	X	Charger is not shutdown
Bit7	Bit6	Bit5	Bit4	Bit3	Bit2	Bit1	Bit0	USB500/100 Control
X	X	X	X	X	X	X	0	Device is always limited to USB100 charge levels
X	X	X	X	X	X	X	1	USB100/500 mode is determined by Register 31[3]

Table 11 – Charging Mode – 8-bit (address: 0Ch) – Non-Volatile								
Bit7	Bit6	Bit5	Bit4	Bit3	Bit2	Bit1	Bit0	Charging Mode
X	X	X	X	X	0	0	X	Power cycle initiates charging
X	X	X	X	X	0	1	X	Power cycle initiates charging only when VBATT < VFLT – 220mV
X	X	X	X	X	1	0	X	Power cycle initiates charging only when VBATT < VFLT – 390mV
X	X	X	X	X	1	1	X	Power cycle initiates charging only when VBATT < VFLT – 550mV



CONFIGURATION REGISTERS (CONT.)

Bit7	Bit6	Bit5	Bit4	Bit3	Bit2	Bit1	Bit0	Configuration Lock
X	X	X	X	X	0	X	X	Unlocked – user can write to non-volatile Configuration bits
X	X	X	X	X	1	X	X	Locked – user cannot write to non-volatile Configuration bits
Bit7	Bit6	Bit5	Bit4	Bit3	Bit2	Bit1	Bit0	User-Memory Lock
X	X	X	X	X	X	0	X	Unlocked – user can write to general purpose EE bits (h20-h2F)
X	X	X	X	X	X	1	X	Locked – user cannot write to general purpose EE bits (h20-h2F)
Bit7	Bit6	Bit5	Bit4	Bit3	Bit2	Bit1	Bit0	Volatile Writes Permission
X	X	X	X	X	X	X	0	No volatile writes to registers h00-h07
X	X	X	X	X	X	X	1	Allow volatile writes to registers h00-h07 (even if h0E[2]=1)

Bit7	Bit6	Bit5	Bit4	Bit3	Bit2	Bit1	Bit0	I ² C EN Polarity (Register 31[4])
0	X	X	X	X	X	X	X	Active low – i.e. when R31[4]=0, charging is enabled
1	X	X	X	X	X	X	X	Active high – i.e. when R31[4]=1, charging is enabled
Bit7	Bit6	Bit5	Bit4	Bit3	Bit2	Bit1	Bit0	I ² C Bus Address
X	0	0	0	X	X	X	X	000
X	0	0	1	X	X	X	X	001
X	0	1	0	X	X	X	X	010
X	0	1	1	X	X	X	X	011
X	1	0	0	X	X	X	X	100
X	1	0	1	X	X	X	X	101
X	1	1	0	X	X	X	X	110
X	1	1	1	X	X	X	X	111
Bit7	Bit6	Bit5	Bit4	Bit3	Bit2	Bit1	Bit0	I ² C Slave Address
X	X	X	X	0	0	0	0	0000
X	X	X	X	0	0	0	1	0001
X	X	X	X	0	0	1	0	0010
X	X	X	X	0	0	1	1	0011
X	X	X	X	0	1	0	0	0100
X	X	X	X	0	1	0	1	0101
X	X	X	X	0	1	1	0	0110
X	X	X	X	0	1	1	1	0111
X	X	X	X	1	0	0	0	1000
X	X	X	X	1	0	0	1	1001
X	X	X	X	1	0	1	0	1010
X	X	X	X	1	0	1	1	1011
X	X	X	X	1	1	0	0	1100
X	X	X	X	1	1	0	1	1101
X	X	X	X	1	1	1	0	1110
X	X	X	X	1	1	1	1	1111

Note 5: Never Write to Reserved bits.



CONFIGURATION STATUS REGISTERS

Table 14 – Volatile Configuration & Charger Enable – 8-bit (address: 31h) – Volatile								
Bit7	Bit6	Bit5	Bit4	Bit3	Bit2	Bit1	Bit0	Volatile Configuration
0	X	X	X	X	X	X	X	Volatile writes to h00-h07 are disabled
1	X	X	X	X	X	X	X	Volatile writes to h00-h07 are enabled (if CFG h0E[0]=1)
Bit7	Bit6	Bit5	Bit4	Bit3	Bit2	Bit1	Bit0	Charger Enable
X	X	X	0	X	X	X	X	Enabled if 0F[7]=0; Disabled if 0F[7]=1
X	X	X	1	X	X	X	X	Disabled if 0F[7]=0; Enabled if 0F[7]=1
Bit7	Bit6	Bit5	Bit4	Bit3	Bit2	Bit1	Bit0	USB500/100 Select (This bit only has an effect when CFG 07[0]=1)
X	X	X	X	0	X	X	X	USB 100mA current level
X	X	X	X	1	X	X	X	USB 500mA current level

Table 15 – Battery status register – 8-bit (address: 36h) – Volatile (read only)								
Bit7	Bit6	Bit5	Bit4	Bit3	Bit2	Bit1	Bit0	Charging Status
1	X	X	X	X	X	X	X	Charger has completed at least 1 successful charge since being enabled
X	1	X	X	X	X	X	X	Charger has completed at least 1 re-charge cycle since being enabled
Bit7	Bit6	Bit5	Bit4	Bit3	Bit2	Bit1	Bit0	Timeout Status
X	X	0	0	X	X	X	X	No timeouts have occurred
X	X	0	1	X	X	X	X	Pre-charge timeout
X	X	1	0	X	X	X	X	Fast-charge timeout
Bit7	Bit6	Bit5	Bit4	Bit3	Bit2	Bit1	Bit0	Charging Status
X	X	X	X	X	0	0	X	Idle
X	X	X	X	X	0	1	X	Pre-charging
X	X	X	X	X	1	0	X	Fast-charging
X	X	X	X	X	1	1	X	Taper-charging
Bit7	Bit6	Bit5	Bit4	Bit3	Bit2	Bit1	Bit0	Charging Status
X	X	X	X	X	X	X	1	Charger is enabled

Table 16 – Battery fault register – 8-bit (address: 37h) – Volatile (read only)								
Bit7	Bit6	Bit5	Bit4	Bit3	Bit2	Bit1	Bit0	Fault Output
1	X	X	X	X	X	X	X	Battery missing
X	1	X	X	X	X	X	X	Charging error
X	X	1	X	X	X	X	X	Battery over-voltage condition
X	X	X	1	X	X	X	X	Charger over-voltage condition
X	X	X	X	1	X	X	X	Charger under-voltage condition
X	X	X	X	X	1	X	X	Temperature too hot
X	X	X	X	X	X	1	X	Temperature too cold
X	X	X	X	X	X	X	1	Termination Detect Current Threshold has been hit

Note 5: Never Write to Reserved bits.



DEFAULT CONFIGURATION REGISTER SETTINGS

Register	Contents	Register	Contents	Register	Contents
00	D2	04	24	0E	01
01	02	05	05	0F	A4
02	0A	07	03		
03	30	0C	00		

The default device ordering number is SMB239E-989. It is programmed with the register contents as shown above.



PRODUCTION PACKAGE DRAWING

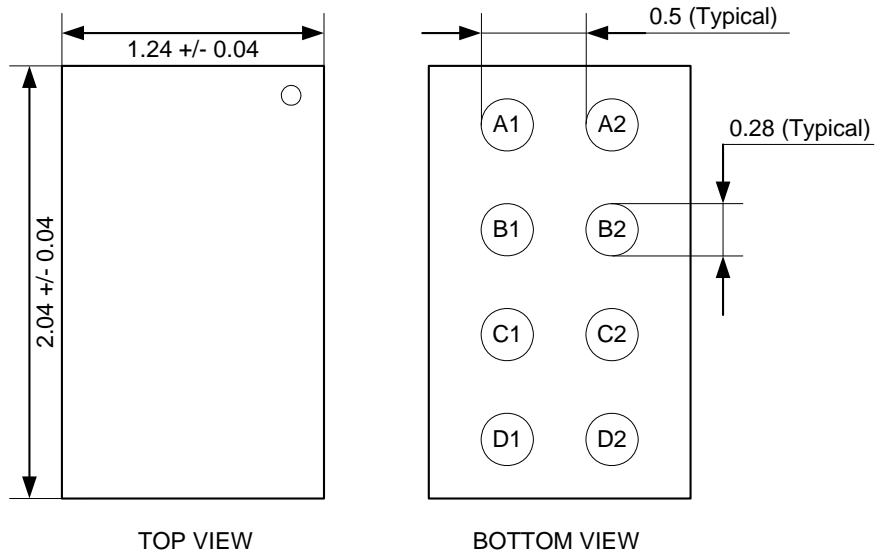

- Notes:
1) All Dimensions in [mm]
2) Drawing not to scale

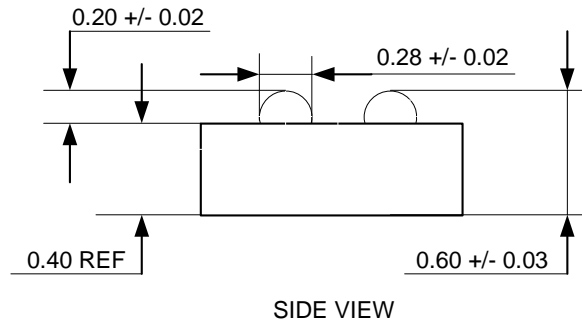

8-Ball Ultra CSP™



PART MARKING

Note: Marking is subject to change – contact factory for more information

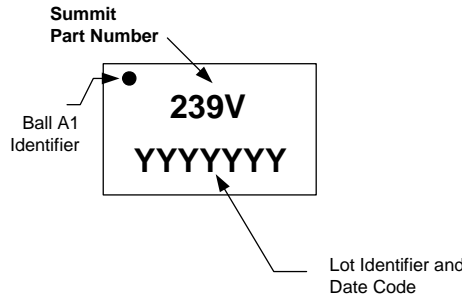

Drawing not to scale

ORDERING INFORMATION

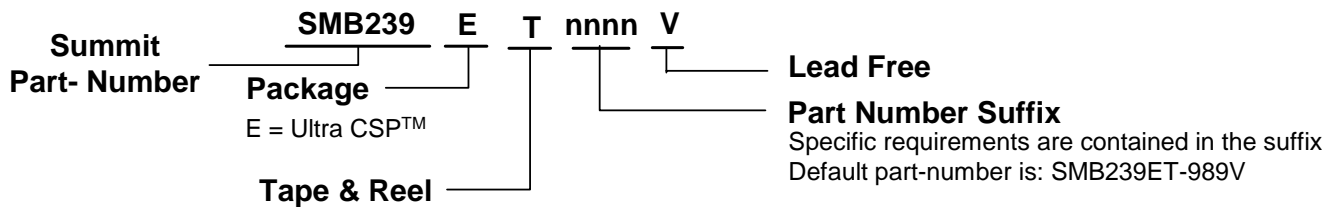

NOTICE

NOTE - This is a final data sheet that describes a Summit product currently in production.

SUMMIT Microelectronics, Inc. reserves the right to make changes to the products contained in this publication in order to improve design, performance or reliability. SUMMIT Microelectronics, Inc. assumes no responsibility for the use of any circuits described herein, conveys no license under any patent or other right, and makes no representation that the circuits are free of patent infringement. Charts and schedules contained herein reflect representative operating parameters, and may vary depending upon a user's specific application. While the information in this publication has been carefully checked, SUMMIT Microelectronics, Inc. shall not be liable for any damages arising as a result of any error or omission.

SUMMIT Microelectronics, Inc. does not recommend the use of any of its products in life support or aviation applications where the failure or malfunction of the product can reasonably be expected to cause any failure of either system or to significantly affect their safety or effectiveness. Products are not authorized for use in such applications unless SUMMIT Microelectronics, Inc. receives written assurances, to its satisfaction, that: (a) the risk of injury or damage has been minimized; (b) the user assumes all such risks; and (c) potential liability of SUMMIT Microelectronics, Inc. is adequately protected under the circumstances.

Revision 3.4 – This document supersedes all previous versions. Please check the Summit Microelectronics Inc. web site at www.summitmicro.com for data sheet updates.

© Copyright 2007 SUMMIT MICROELECTRONICS, Inc. **PROGRAMMABLE POWER FOR A GREEN PLANET™**

I²C is a trademark of Philips Corporation