

SMB135 – Tiny Battery Charger offers shortest Charging Time and lowest Power Dissipation

Highlights

- **USB TurboCharge™:** Get up to 750mA Charge Current from 500mA USB Port*!
- 1.3mm x 2.1mm Chip Scale Package Trims PCB Footprint by 69%
- Switch-Mode Architecture Cuts Power Dissipation by 89% and Eliminates “Hot” Spots
- Configurable Charging Parameters for Static & Dynamic Design Flexibility

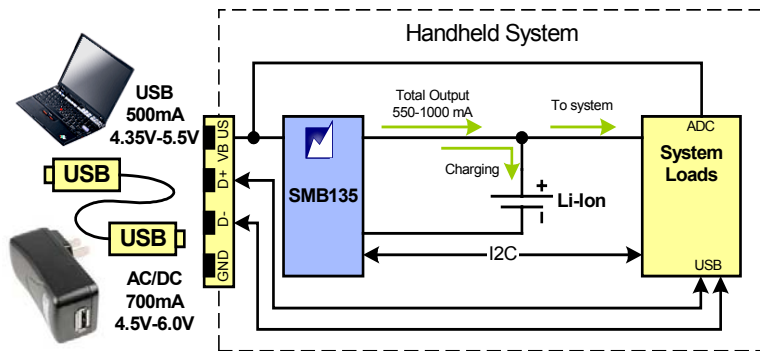

Features

- +4.35V to +6.0V Input Range
- OV Protection & 10V Absolute Max. Rating
- High-performance, Switch-mode Architecture
- I²C/SMBus Serial Interface
- Fully Programmable Algorithm in EEPROM
 - Charge Current (47.5mA-1050mA)
 - Pre-charge Current (25mA-425mA)
 - Termination Current (25mA-374mA)
 - Float Voltage (4.00V-4.62V)
 - Pre-Charge Threshold (2.4V-3.1V)
 - Cell Temperature Safety Limits
 - Safety Timer Limits
- Charge Status Indicator Output
- Battery Cell Temperature Monitor
- USB 500mA/100mA Host/Bus Power Selector
- ±1% Float Voltage Accuracy
- Very Low Reverse Leakage Current

Applications

- 2.5G/3G Handsets
- Smartphones/PDA Phones
- Bluetooth Headsets
- Portable MP3/MPEG-4 & Gaming Players
- Handheld GPS Terminals
- Digital Still Cameras

Li-Ion USB Charging

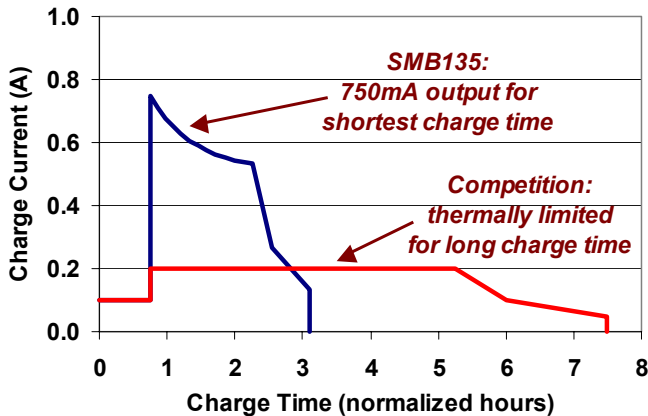

Power Dissipation @ 750mA

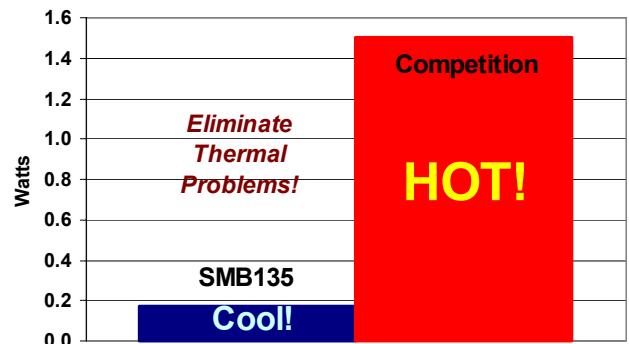

SUMMIT
MICROELECTRONICS, Inc.

“Programmable Power for a Digital World”

* Patent pending

SMB135 – Tiny Battery Charger offers shortest Charging Time and lowest Power Dissipation

GUI allows easy programming of all functions and parameters in a real-time environment

Battery Charger Configuration

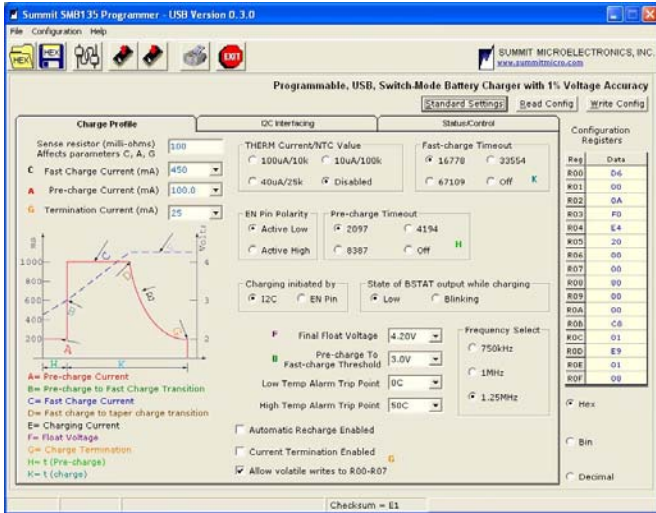

Battery Charger Evaluation Board

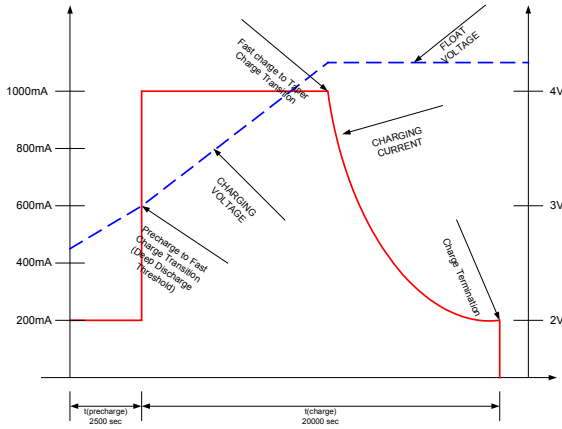
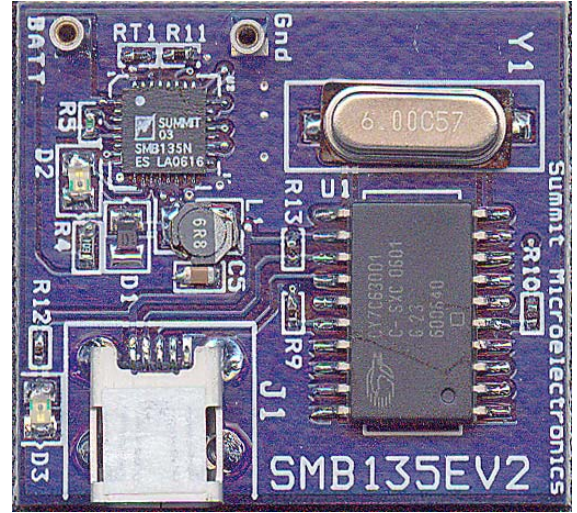

Configurable Charging Parameters Allow Unparalleled Static & Dynamic Design Flexibility:

- Pre-Charge Current
- Pre-Charge to Fast Charge Voltage
- Fast Charge Current
- Float Voltage
- Termination Current
- Temperature Limits
- Charge Safety Timers

Complete Programmable Power Manager Offering

Output Channels	SMB135	SMB122	SMB120	SMB118	SMB110	SMB111	SMB112	SMB113	SMB117
Total # of Outputs	1	9	9	7	5	4	5	4	4
Step-down (Buck)		3 to 4	4	3 to 4	2	3	1	4	4
Step-up (Boost)		2 to 4	3	1 to 2	1	1	2		
Inverter (Buck-Boost)		0 to 1	1		1		1		
Battery Charger	1	1		1					
LDO		1	1	1	1		1		
Package Size (mm)	1.3 x 2.1	9x9	9x9	7x7	5x5	5x5	5x5	5x5	5x5
Package Type	CSP-15	QFN-64	QFN-64	QFN-48	QFN-32	QFN-32	QFN-32	QFN-32	QFN-32



"Programmable Power for a Digital World"